

APÊNDICE A.1

RETIGRÁFICOS

CONCESSÃO DOS SERVIÇOS PÚBLICOS DE AMPLIAÇÃO, OPERAÇÃO, CONSERVAÇÃO, MANUTENÇÃO E REALIZAÇÃO DOS INVESTIMENTOS NECESSÁRIOS PARA A EXPLORAÇÃO DO SISTEMA RODOVIÁRIO DENOMINADO LOTE NOROESTE

1. RETIGRÁFICOS

Este APÊNDICE tem como objetivo apresentar os retrógraficos das rodovias pertencentes ao Lote Noroeste. Os retrógraficos apresentados representam a situação atual e projetada das rodovias.

Nos retrógraficos são destacados os elementos rodoviários ou qualquer mudança que ocorra na rodovia como, por exemplo:

- N° de faixas;
- Início e Término de Trechos Urbanos;
- Início e Término de Vias Marginais;
- Tipo de dispositivo nos entroncamentos e seus respectivos nomes;
- Etc.













É importante ressaltar que o posicionamento dos elementos rodoviários apresentados na situação futura é referencial, cabendo à concessionária definir em conjunto com o poder concedente/ARTESP a posição final de cada elemento.







Serão apresentados retrógraficos na seguinte sequência:

- Rodovia SP 310;
- Rodovia SP 323;
- Rodovia SP 326;
- Rodovia SP 333;
- Rodovia SP 351.

Os retrógraficos estão representados em função dos marcos quilométricos atualmente cadastrados na rodovia e são representativos das condições existentes e futuras da rodovia.

Legenda

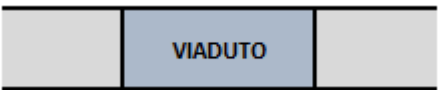
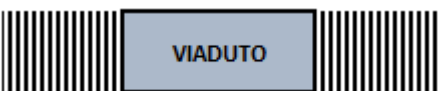
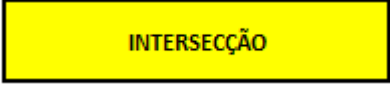
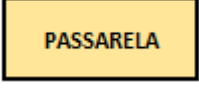
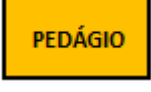
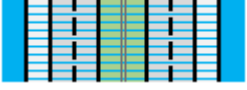
Simples com acostamento de terra	
Simples com acostamento pavimentado	
Simples sem acostamento	
Pista de terra	
Simples com faixa adicional	
Dupla sem canteiro central sem faixa adicional	
Dupla sem canteiro central com faixa adicional	
Dupla com canteiro central sem faixa adicional	
Dupla com canteiro central com faixa adicional	
Tripla sem canteiro central sem faixa adicional	
Tripla sem canteiro central com faixa adicional	
Tripla com canteiro central sem faixa adicional	
Tripla com canteiro central com faixa adicional	

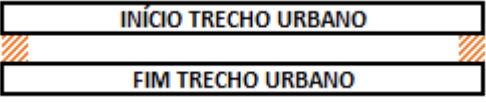
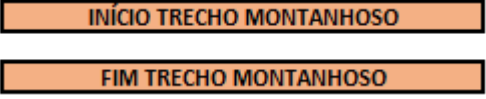
Multifaixa	
Marginal	
Ciclovia	
Ponte	
Viaduto	
Viaduto sobre linha férrea	
Intersecção	
Passarela de pedestres	
Praça de Pedágio	
Galeria	
Passagem de gado	
Trecho Urbano	
Trecho Montanhoso	

Trecho Comum	 
Acesso	
Balança Móvel	
Posto Geral de Fiscalização	
Base SAU	
Posto de Abastecimento	
Polícia Militar Rodoviária	
Ponto de Ônibus	
Radar de Monitoramento de Velocidade	
Painel de Mensagens Variáveis	
Rampa de Escape	
Área de Refúgio (baia)	

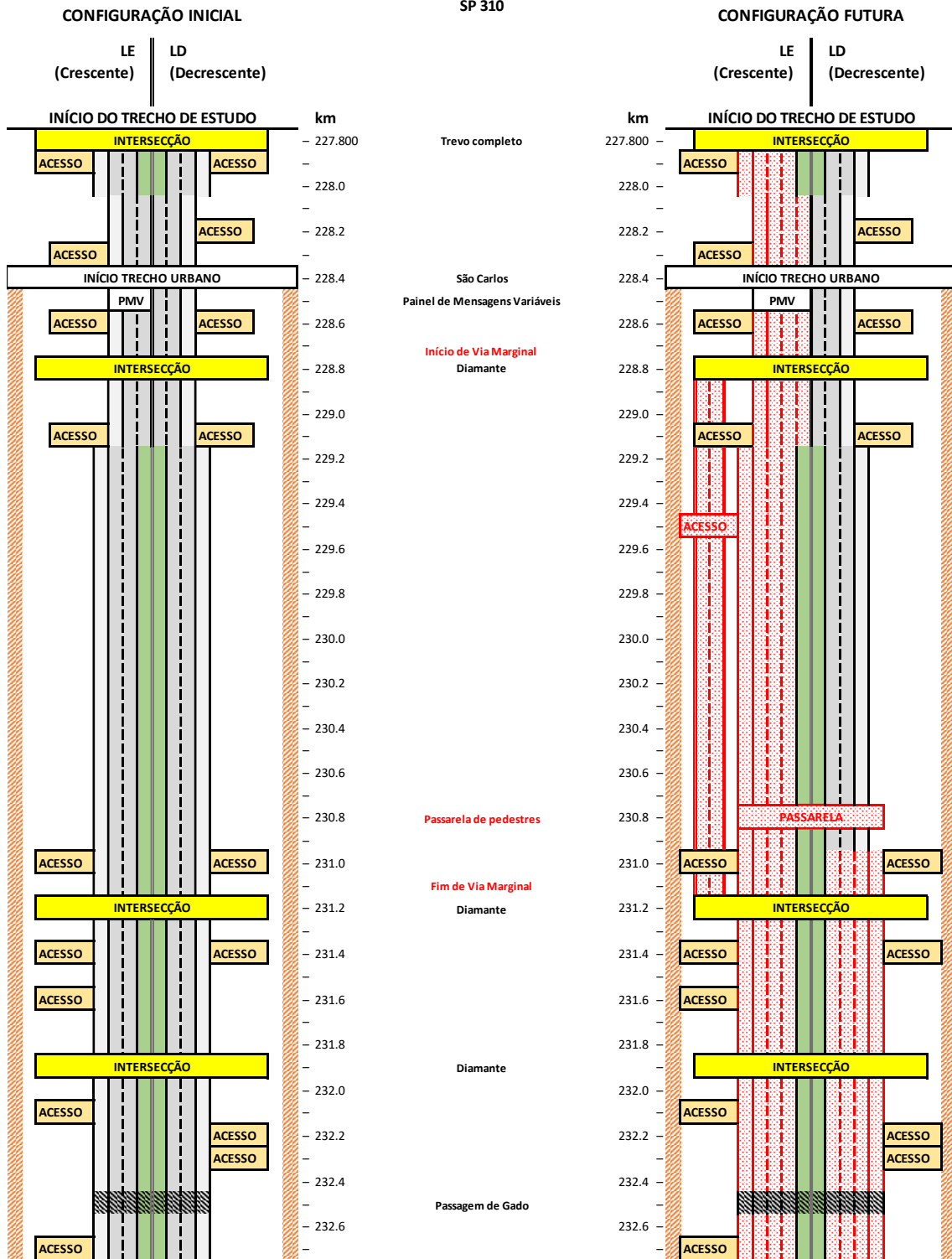

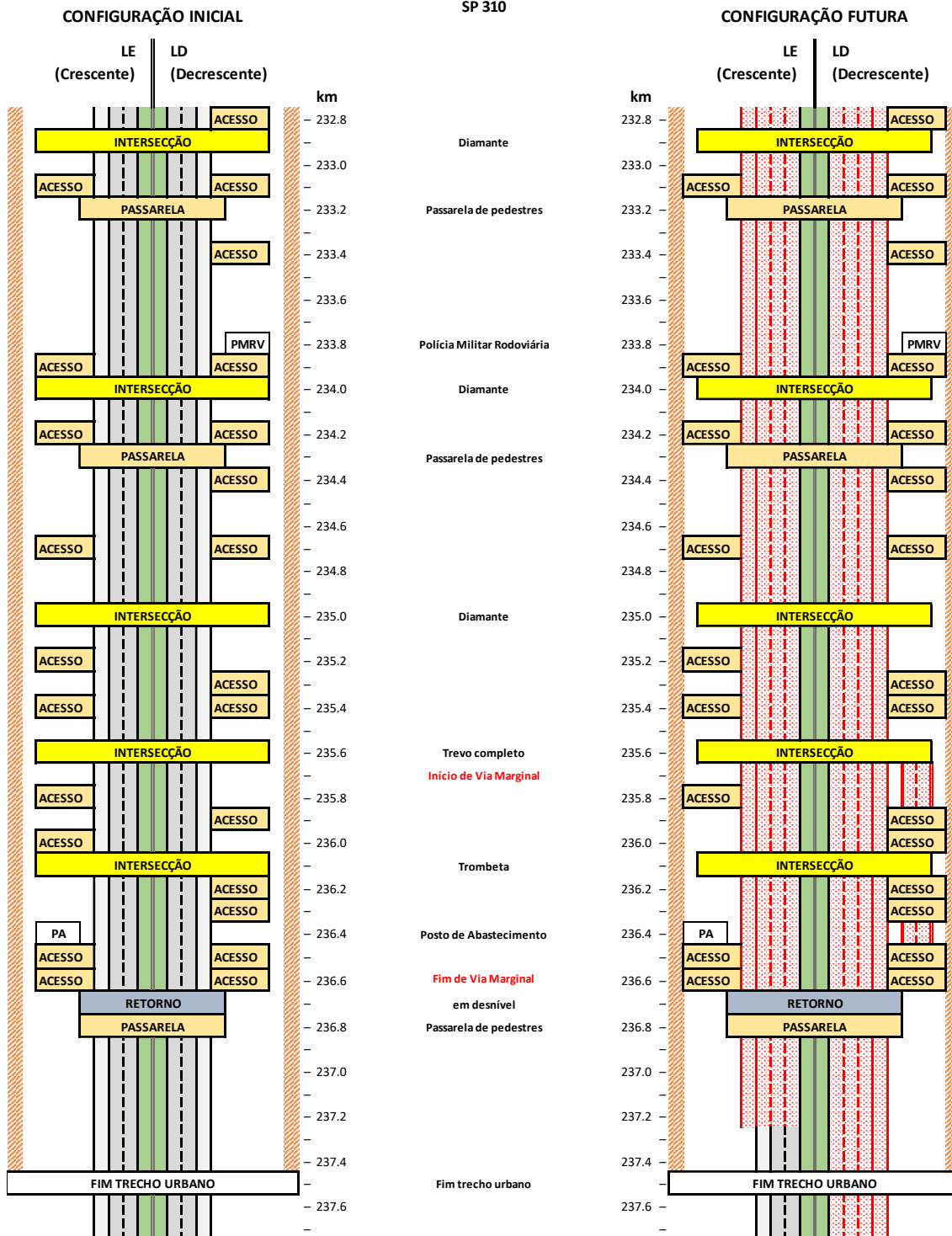

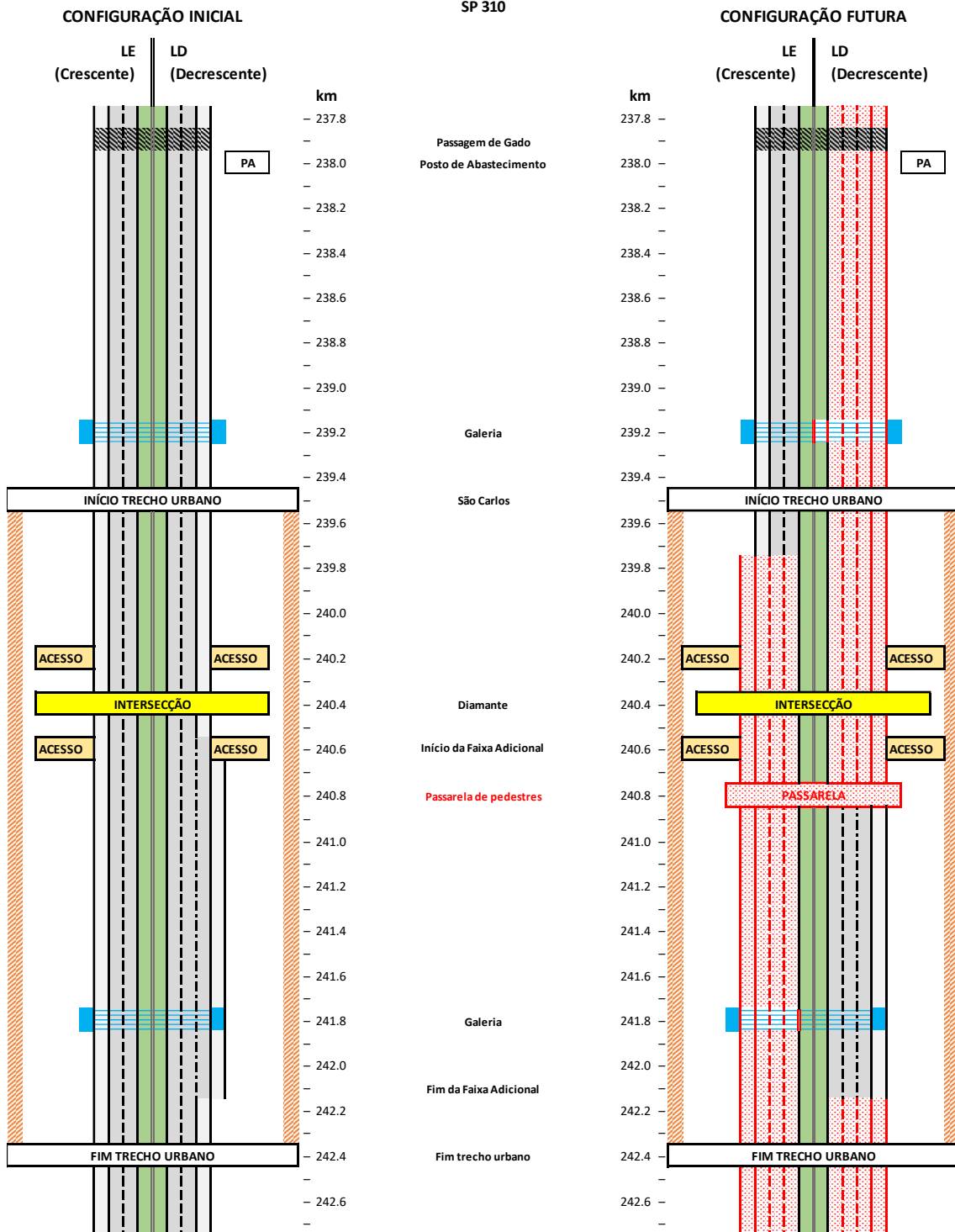

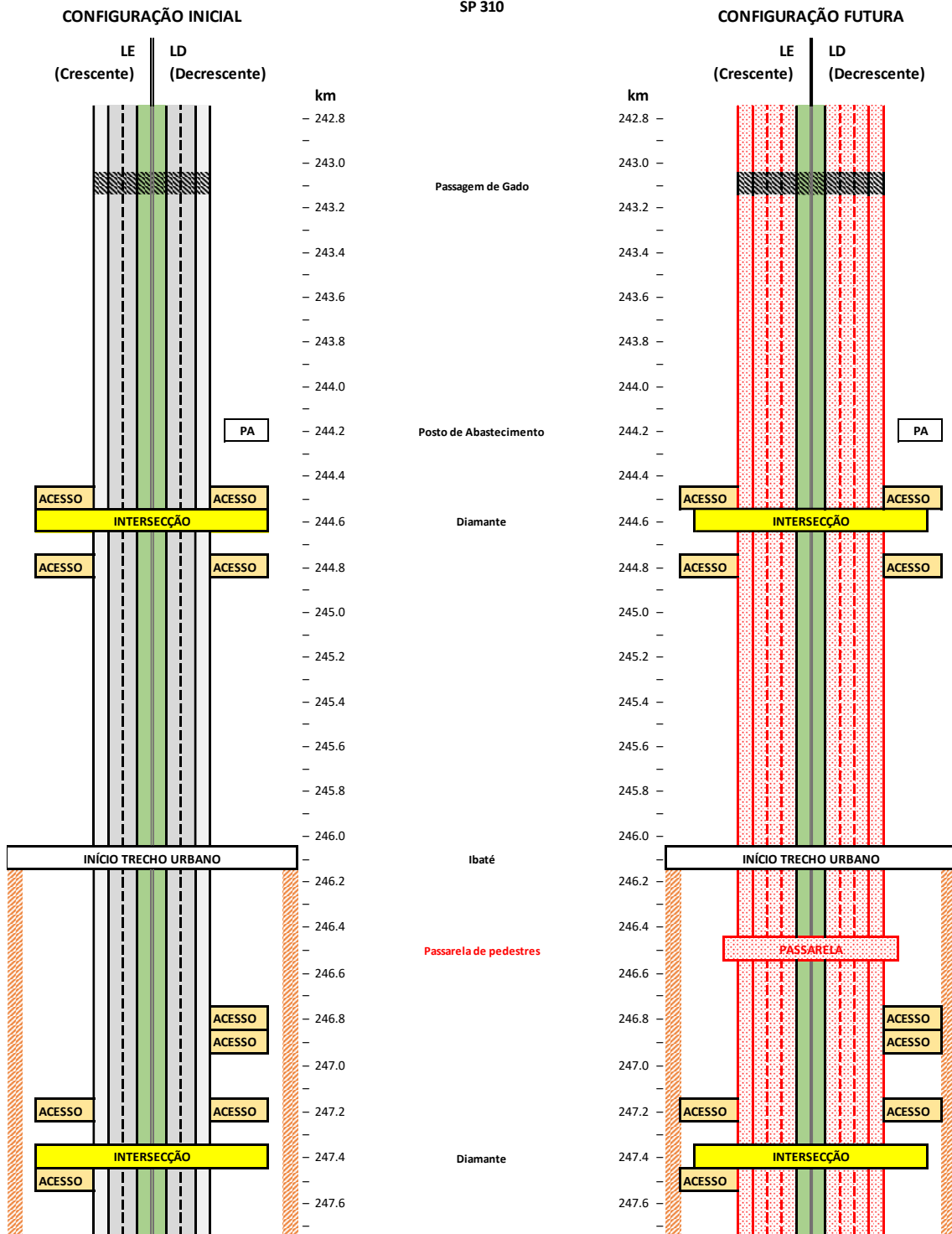

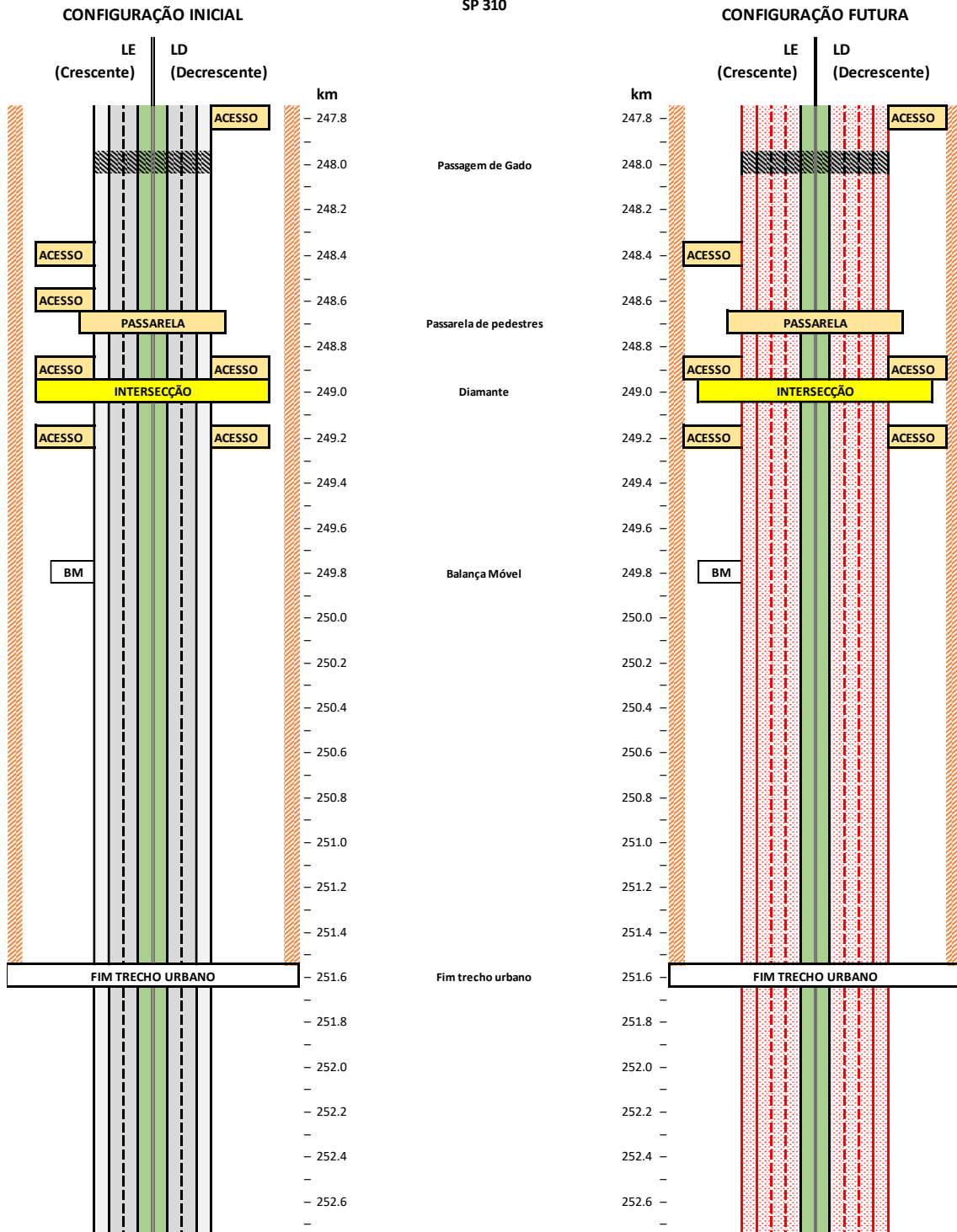

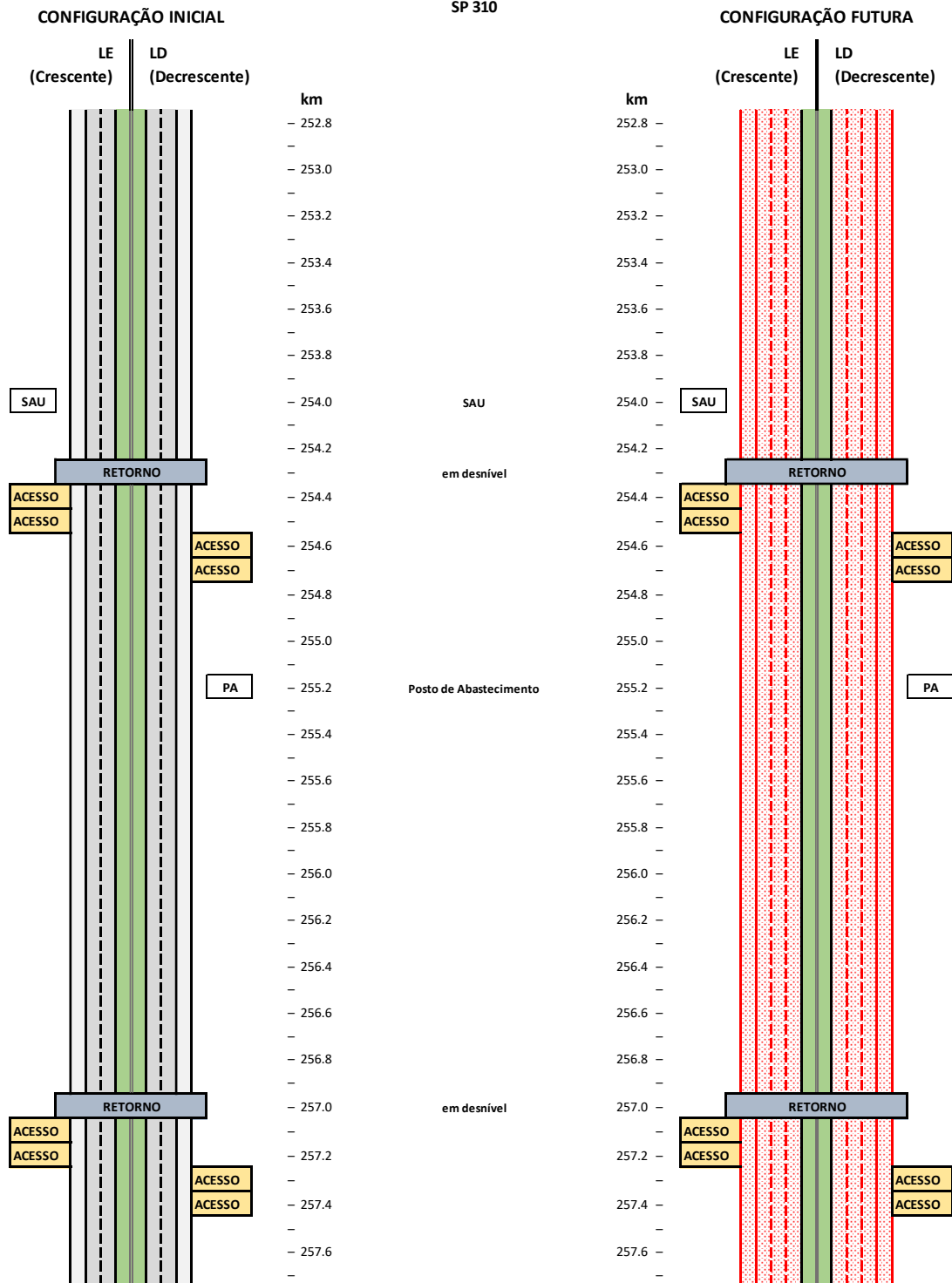

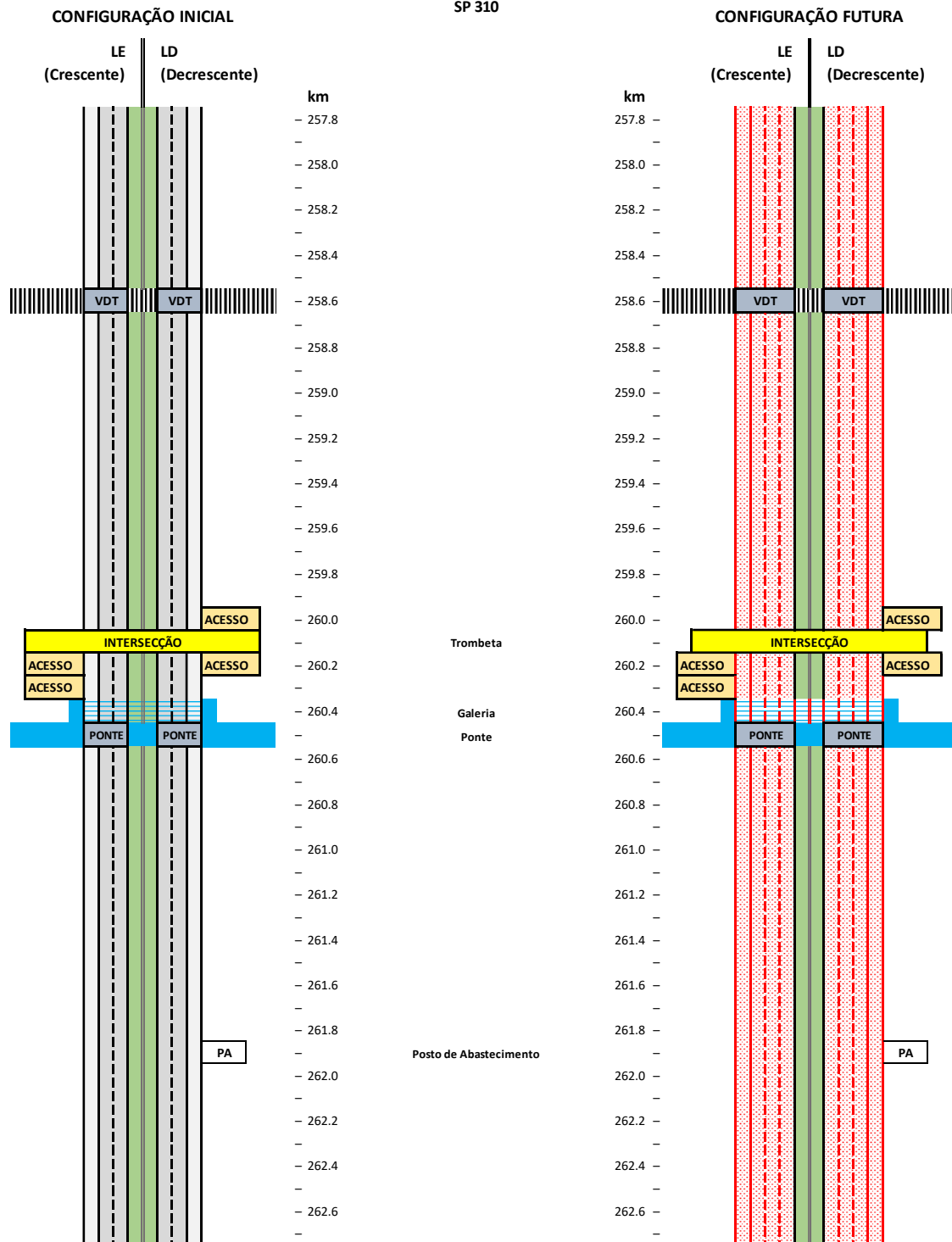

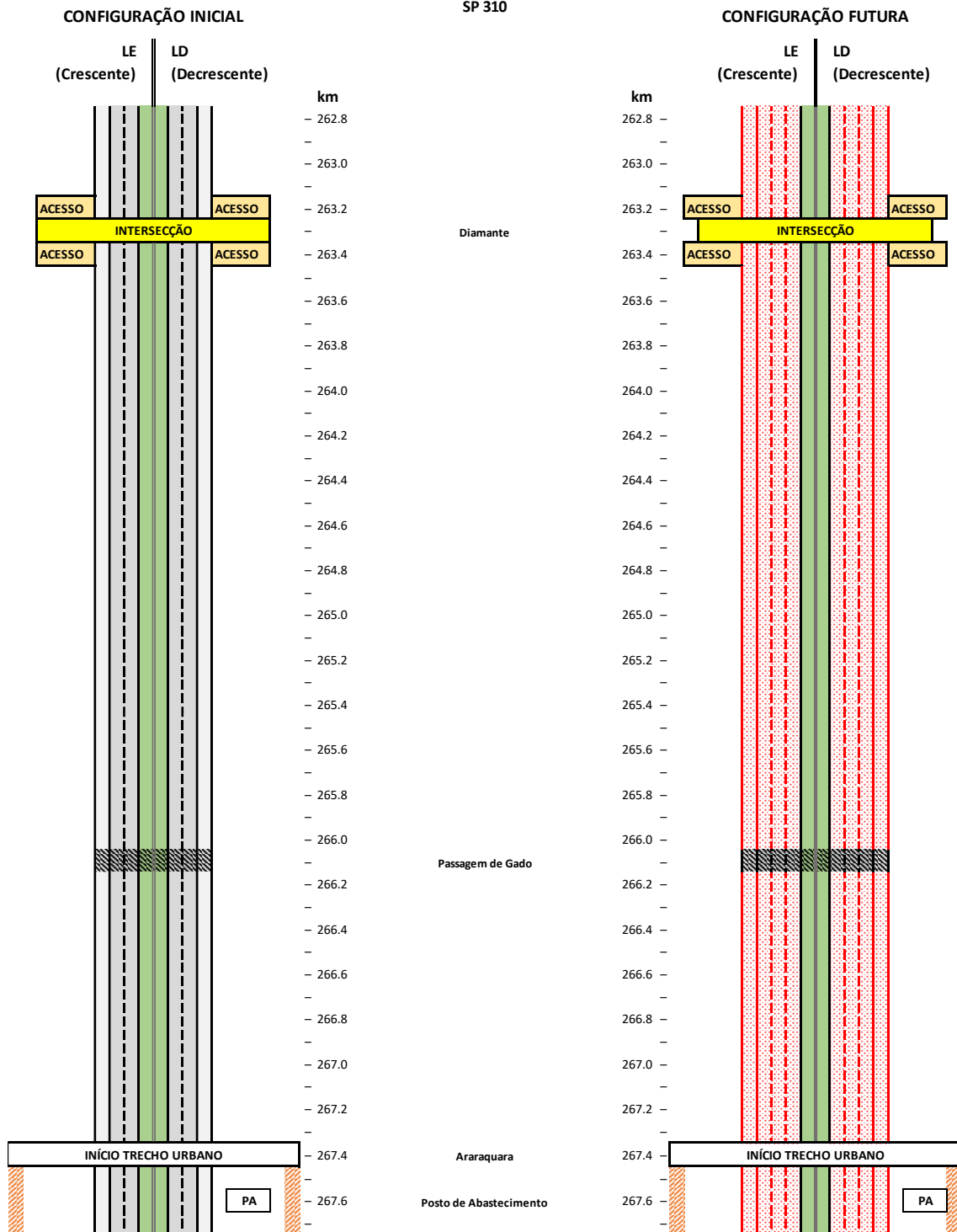

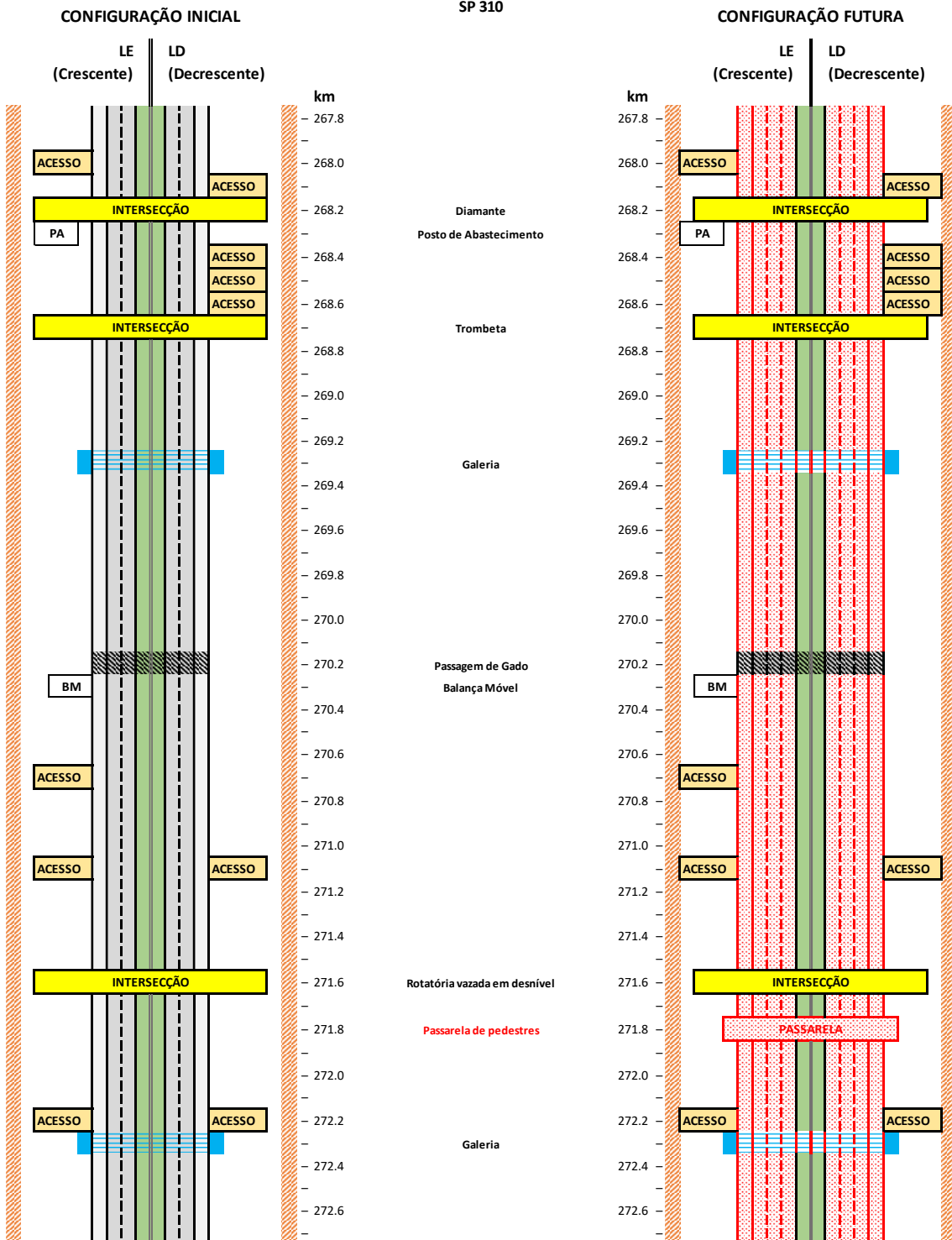

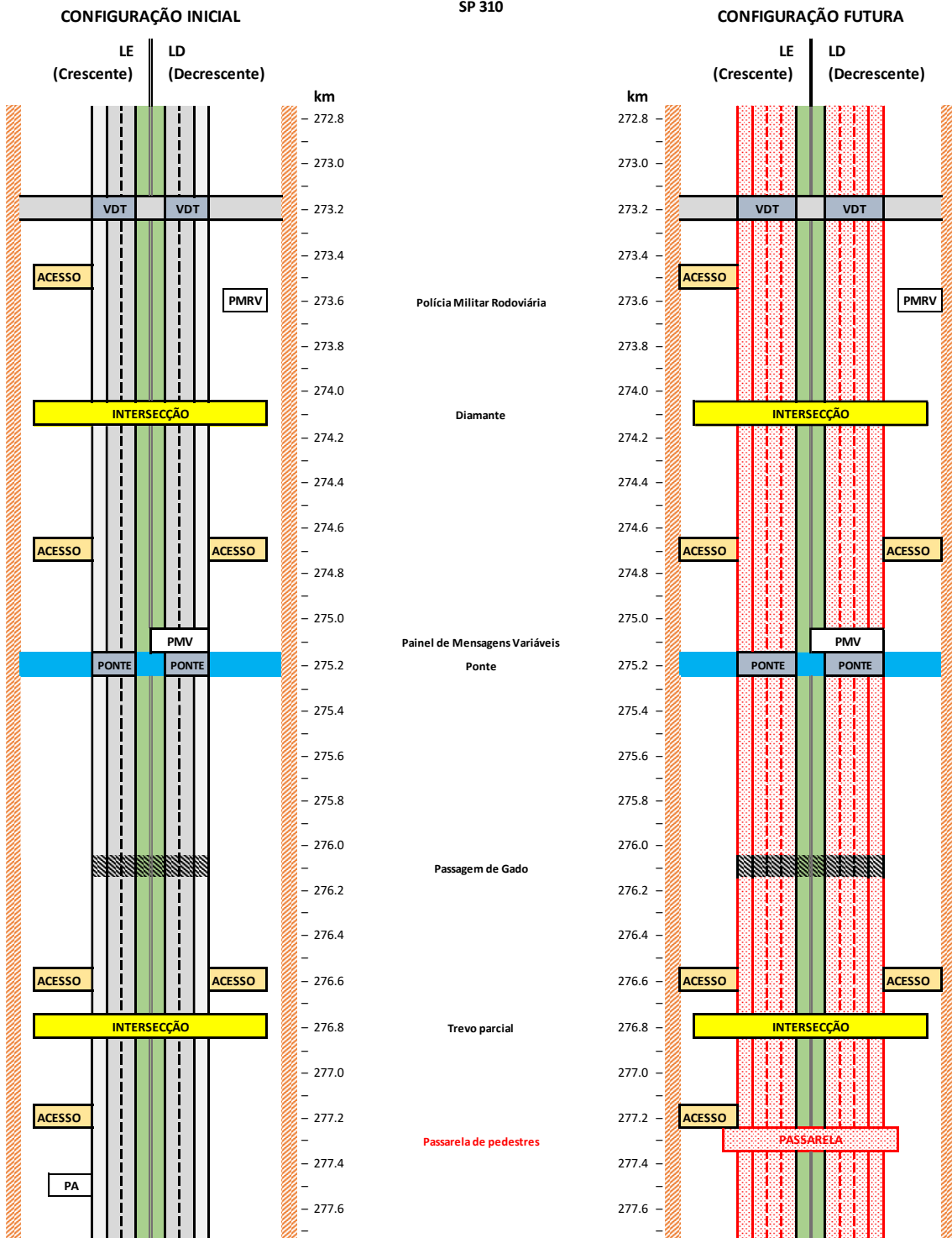

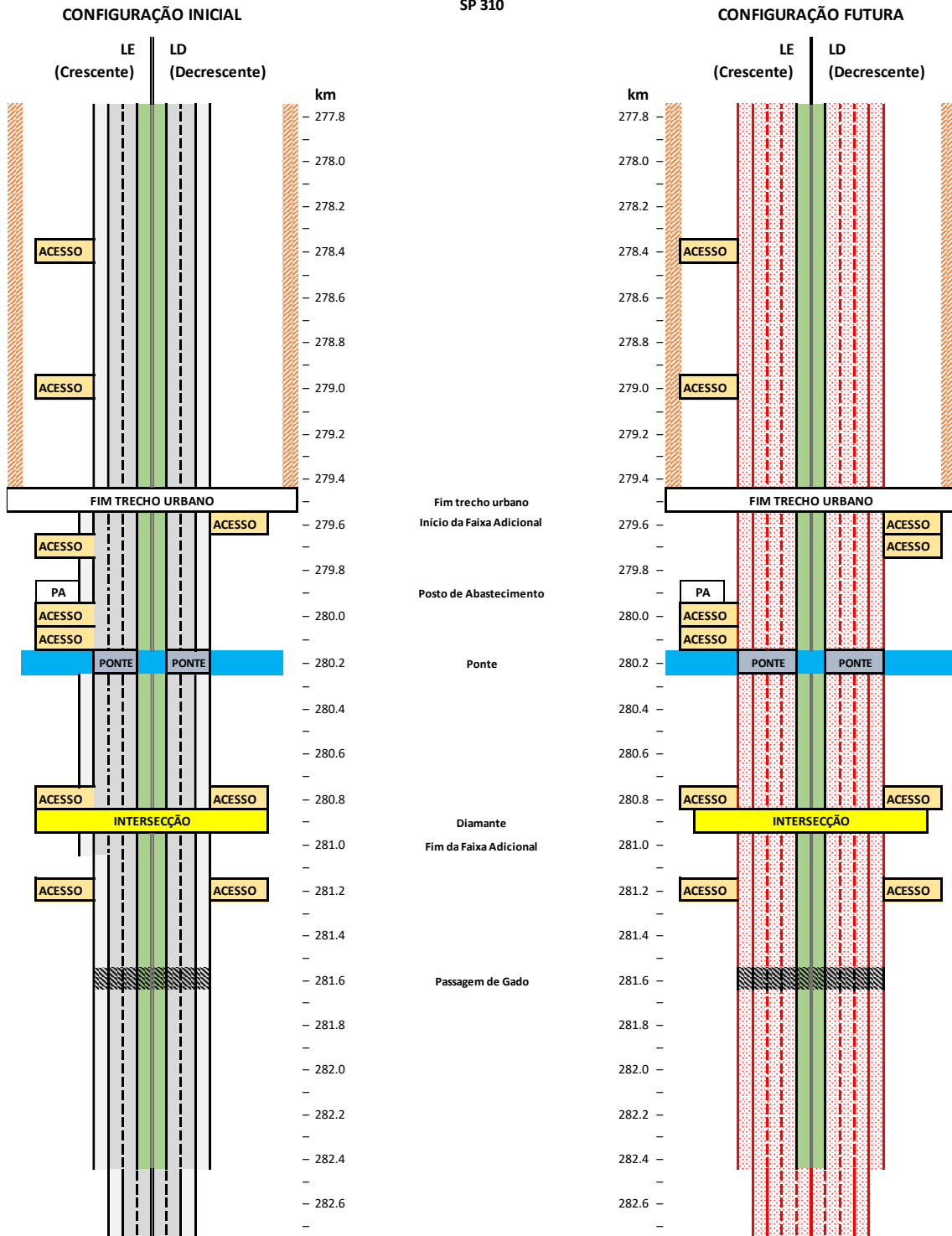

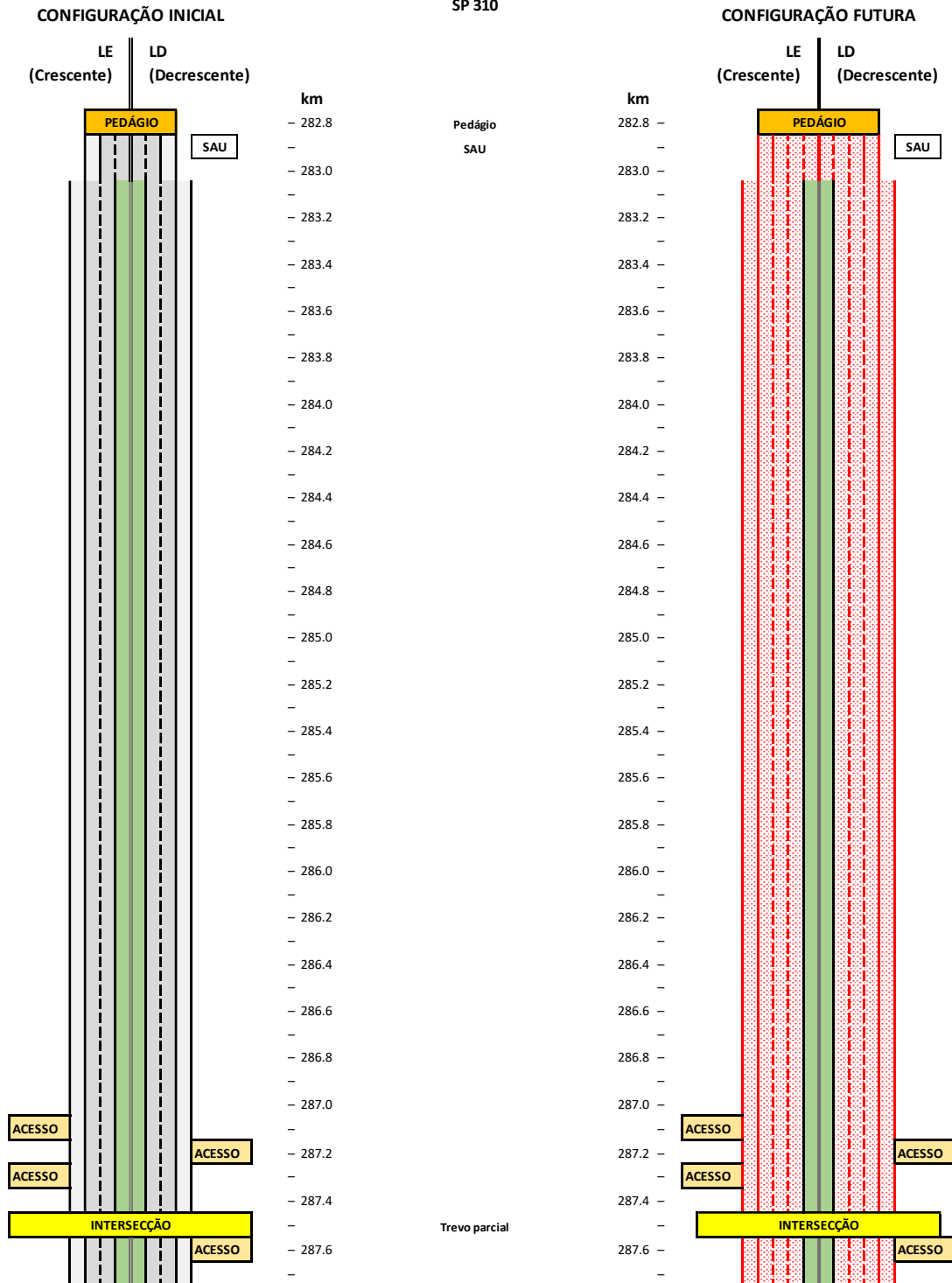



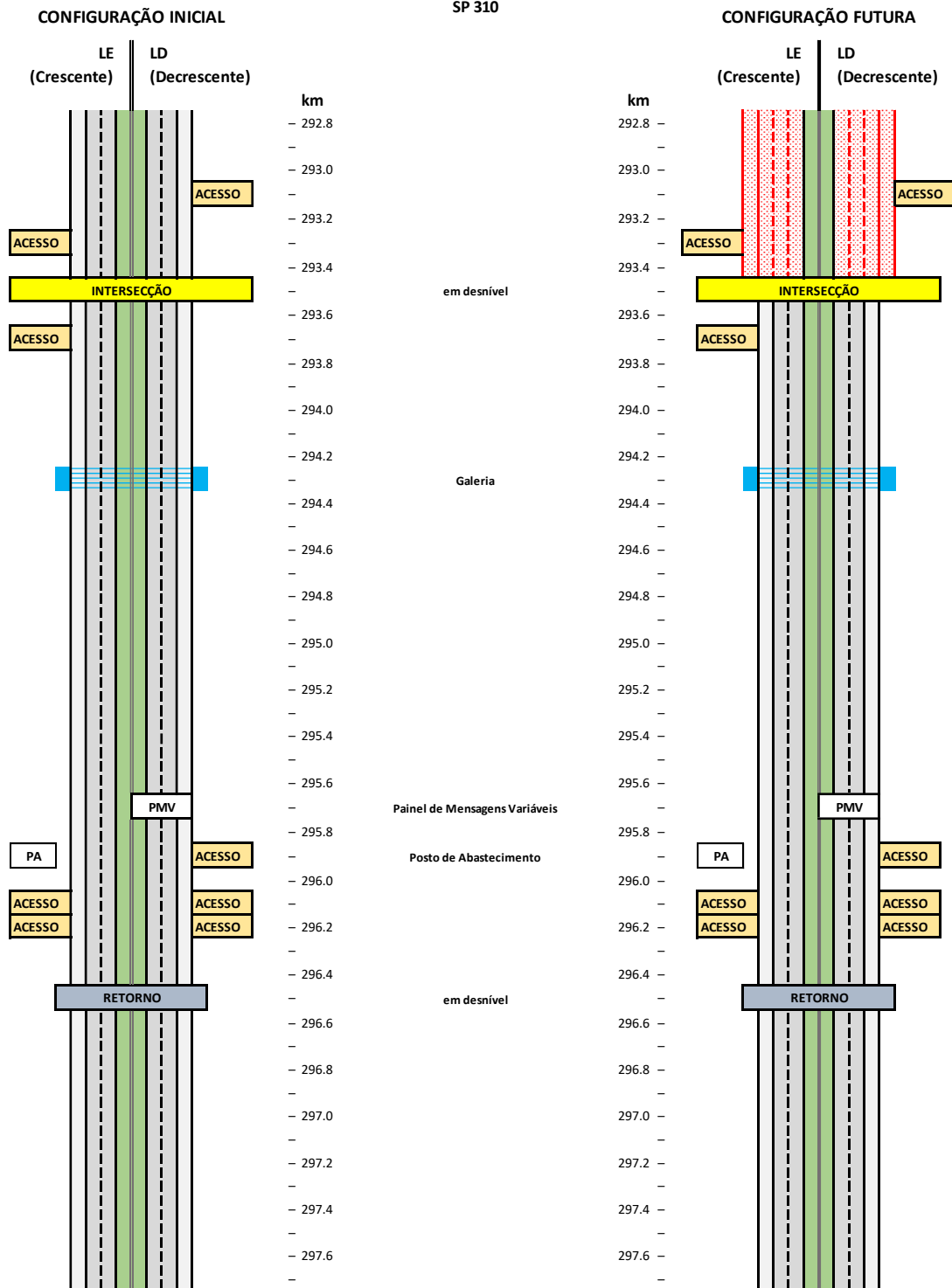

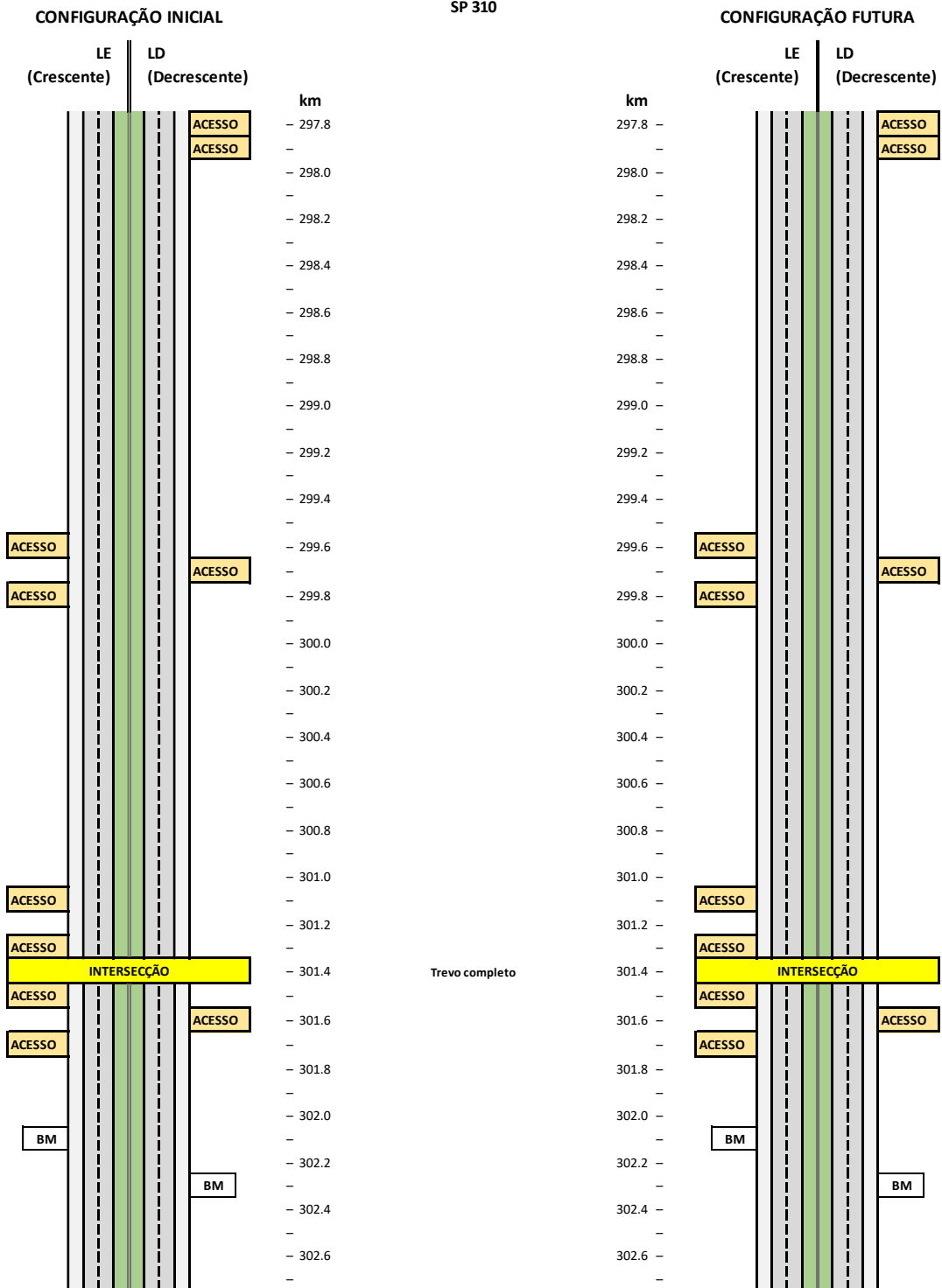

CONFIGURAÇÃO INICIAL

LE (Crescente) | LD (Decrescente)

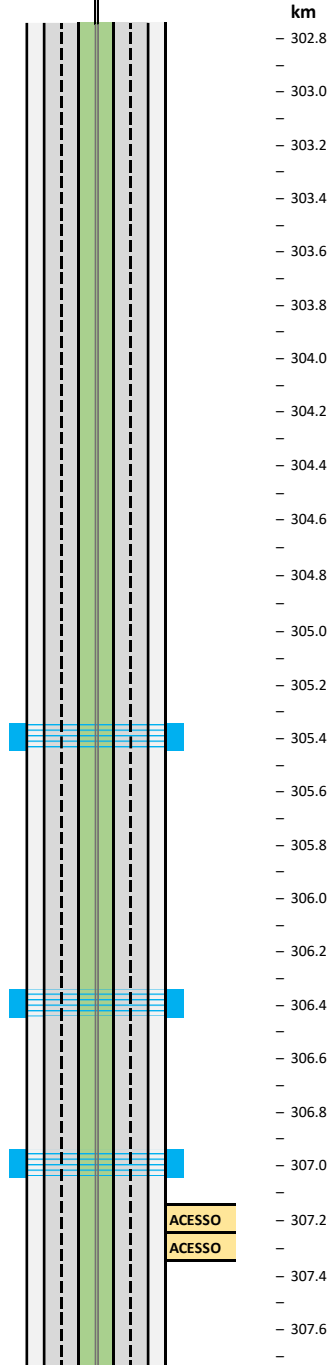

SP 310

CONFIGURAÇÃO FUTURA

LE (Crescente) | LD (Decrescente)

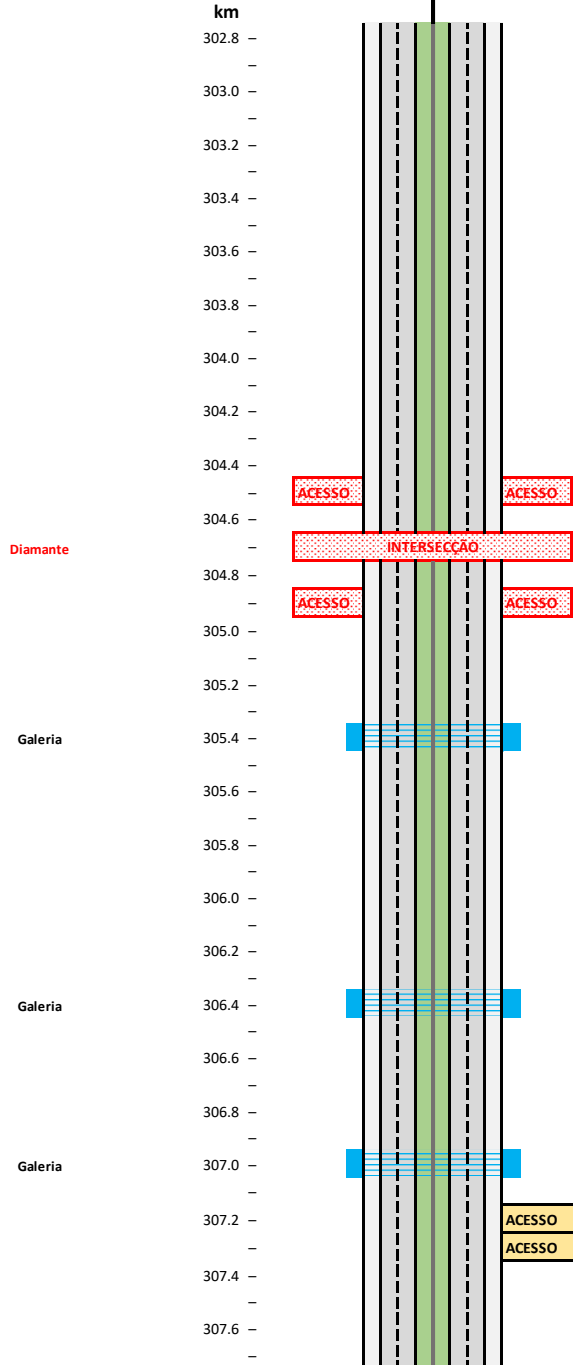

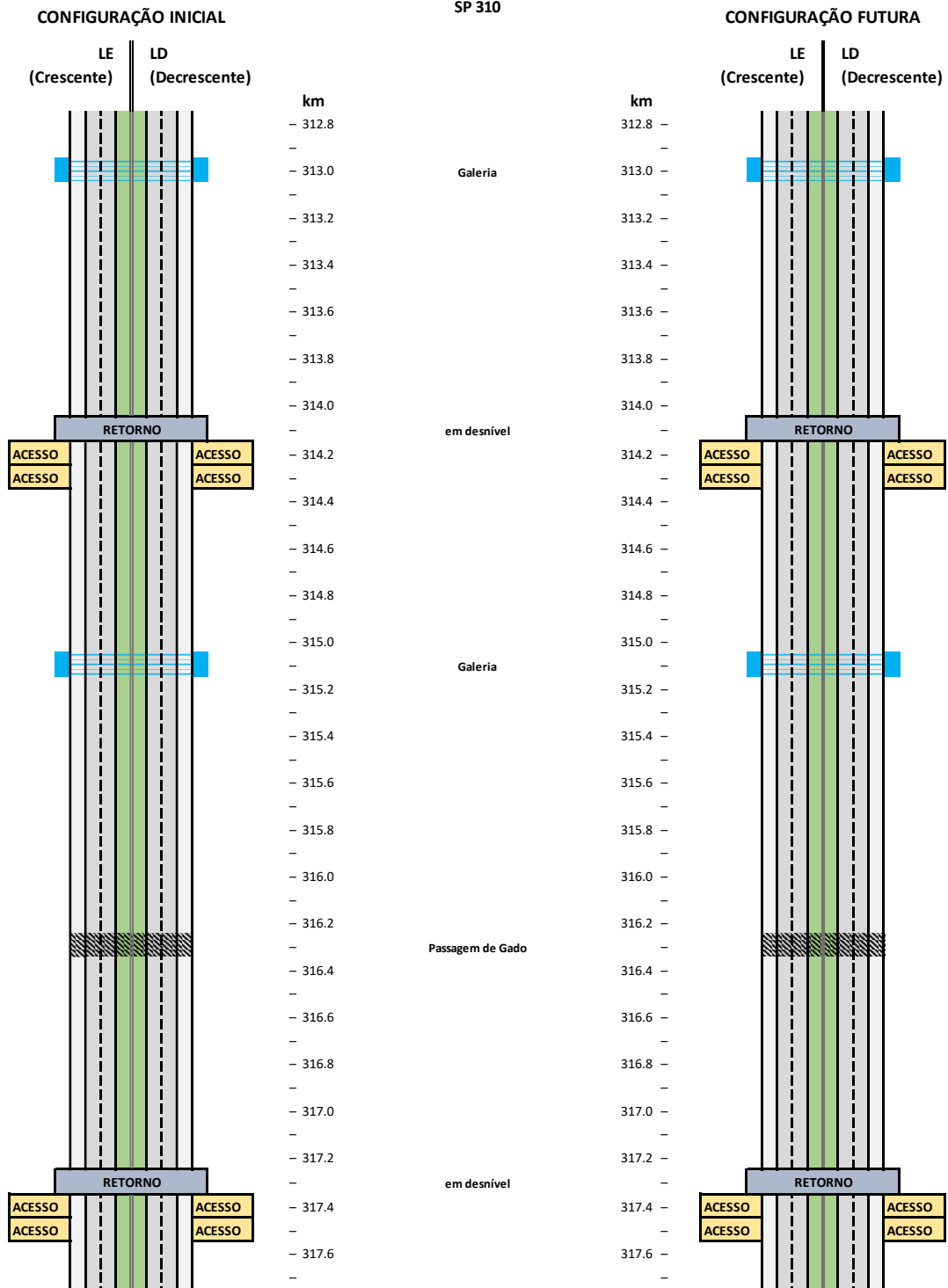

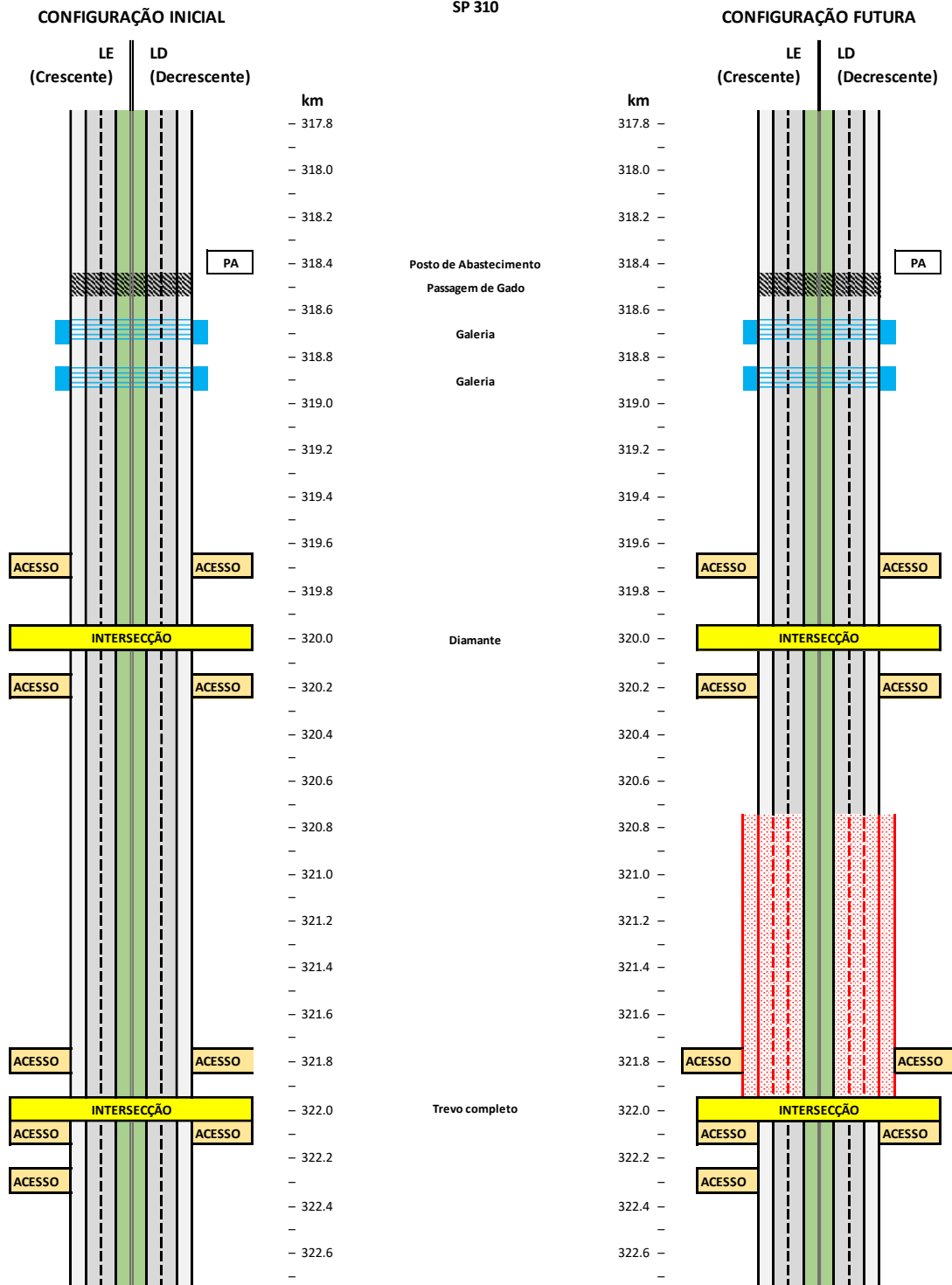

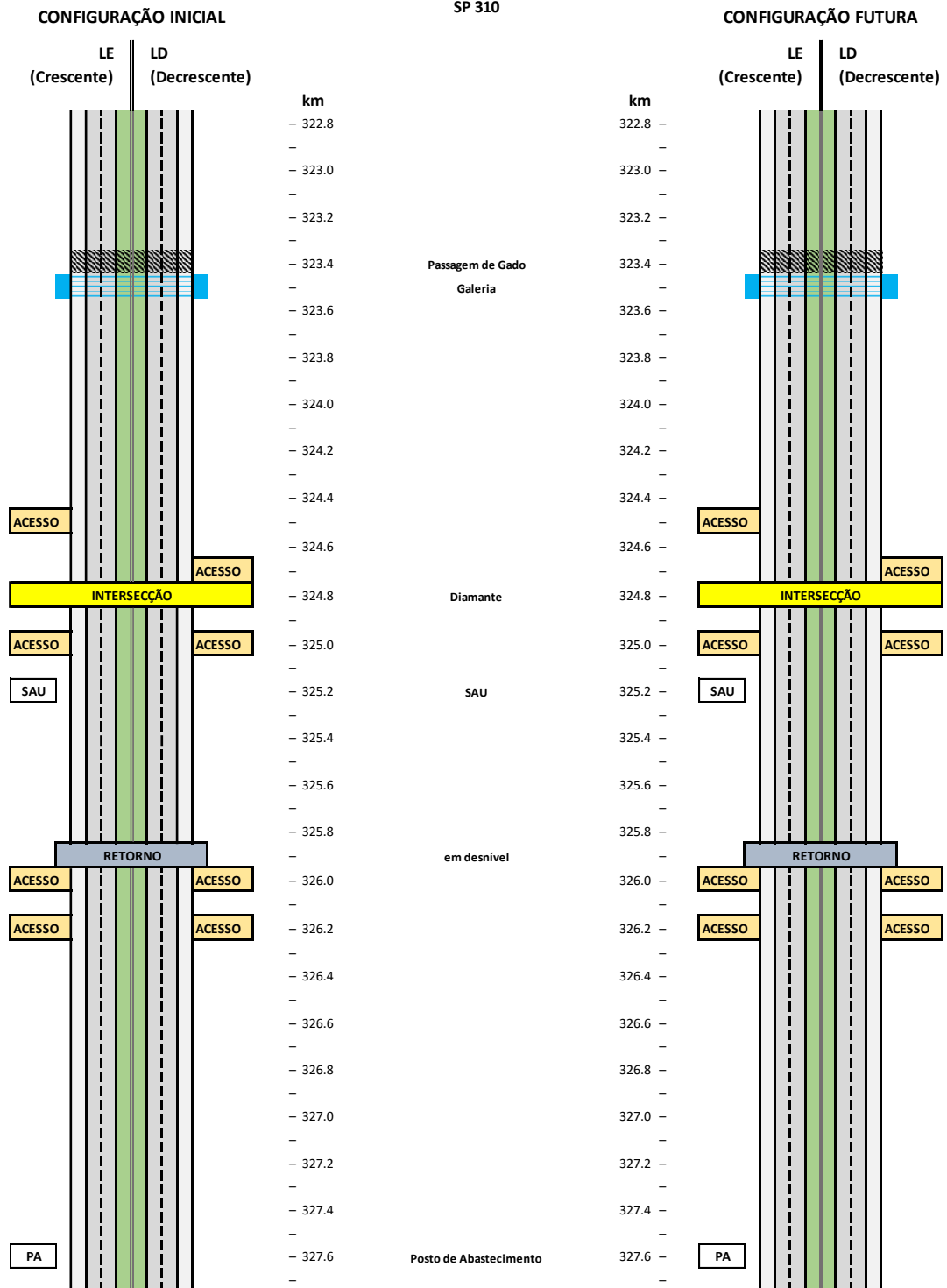

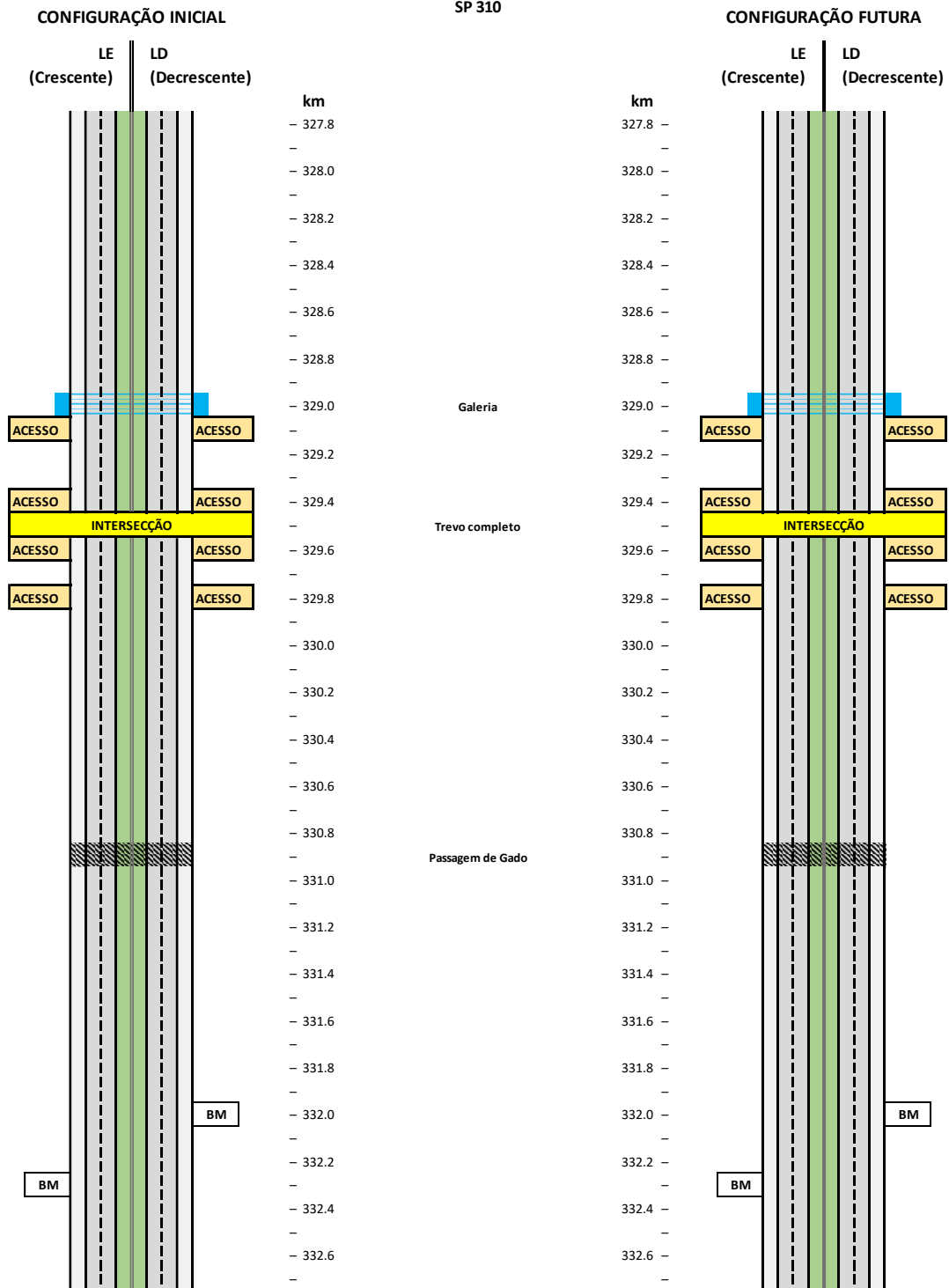

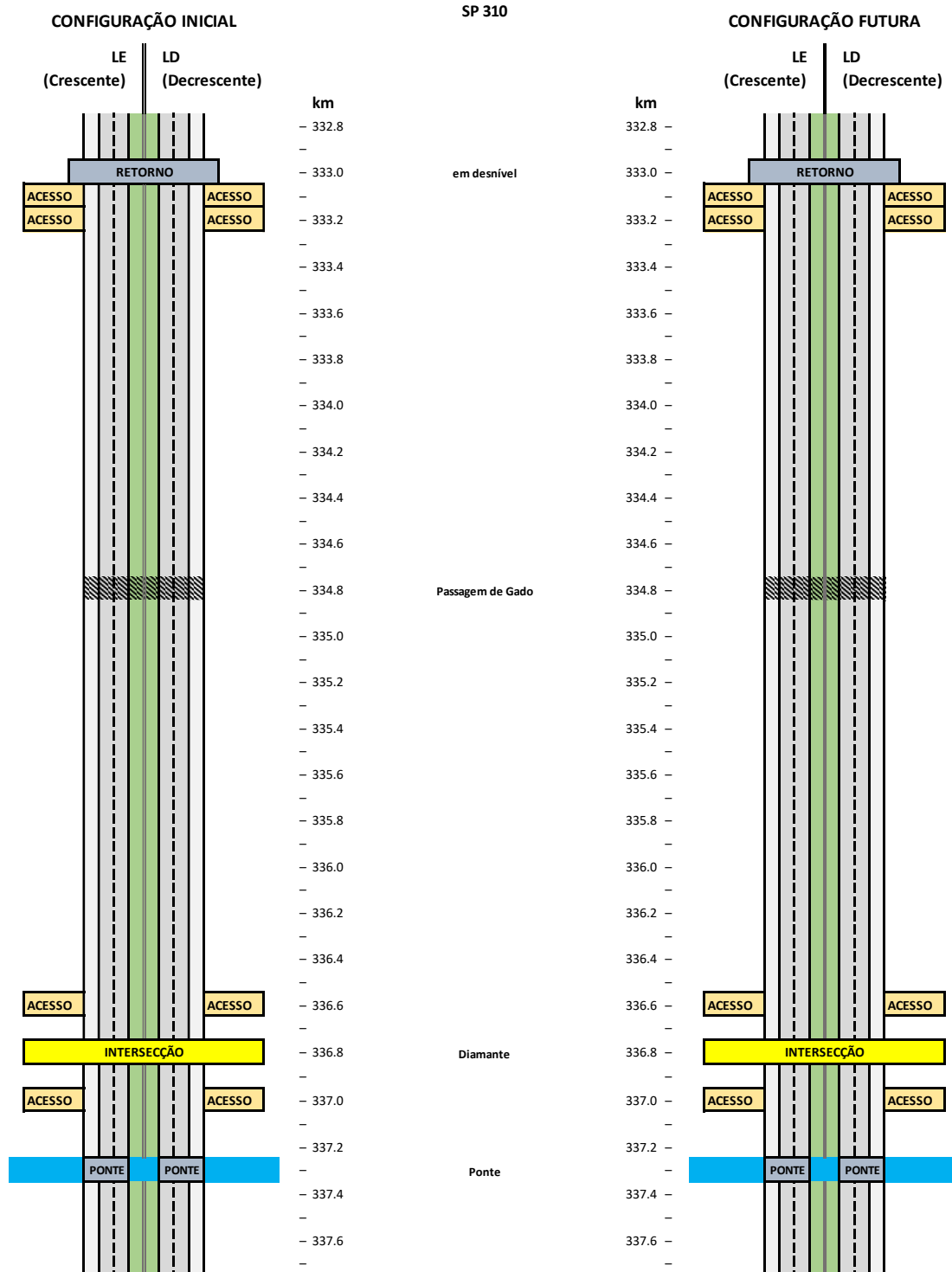

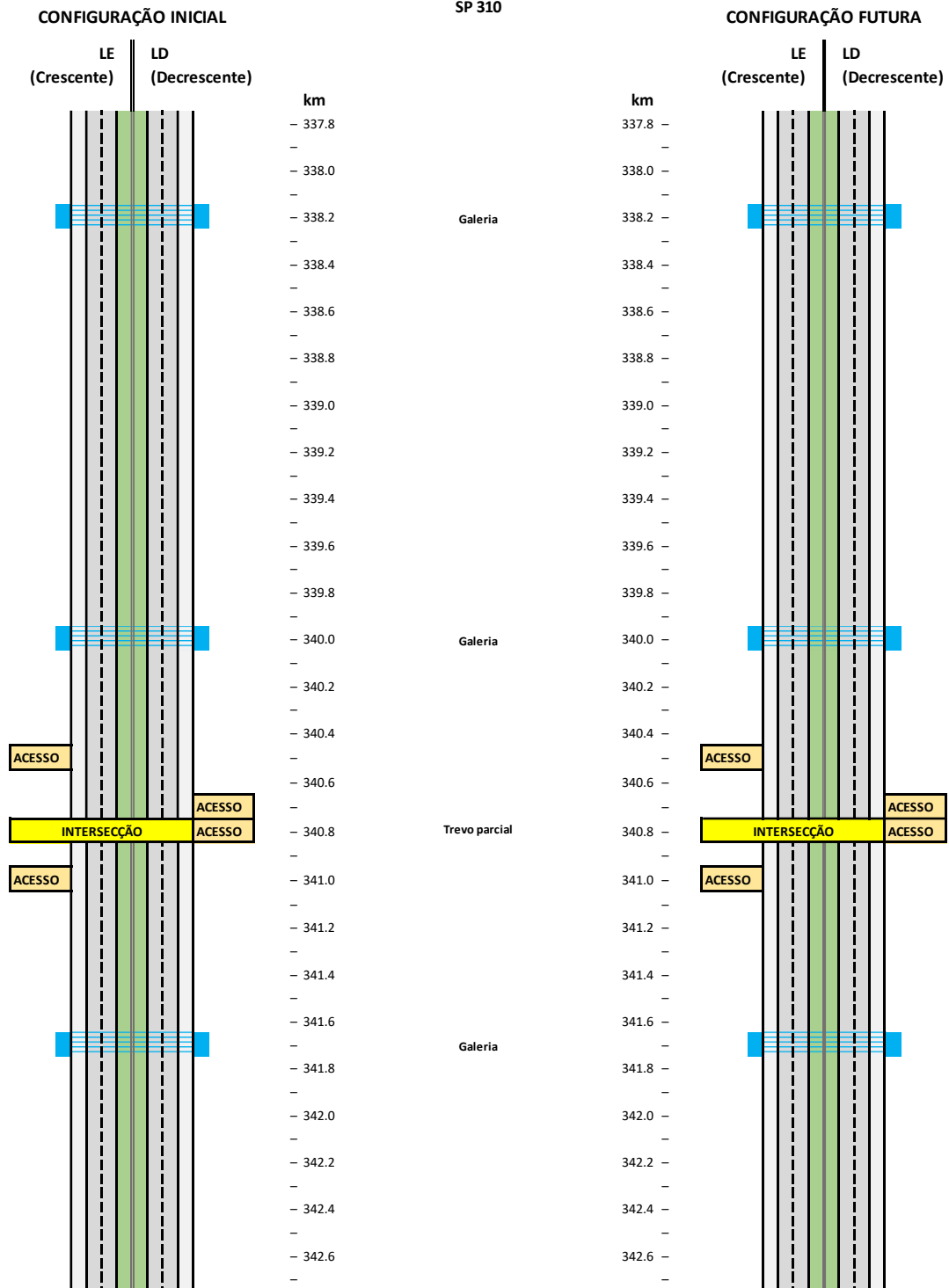

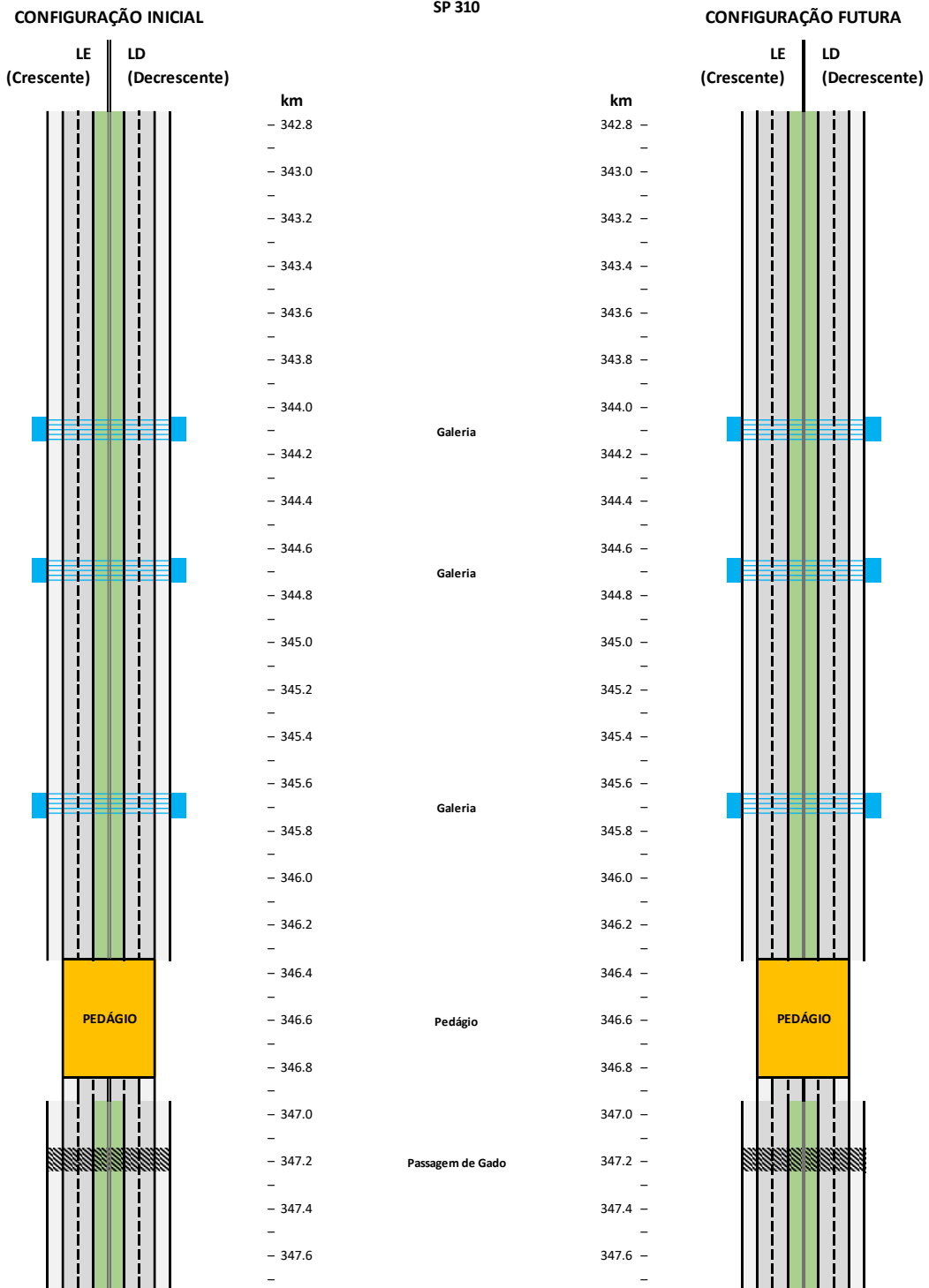

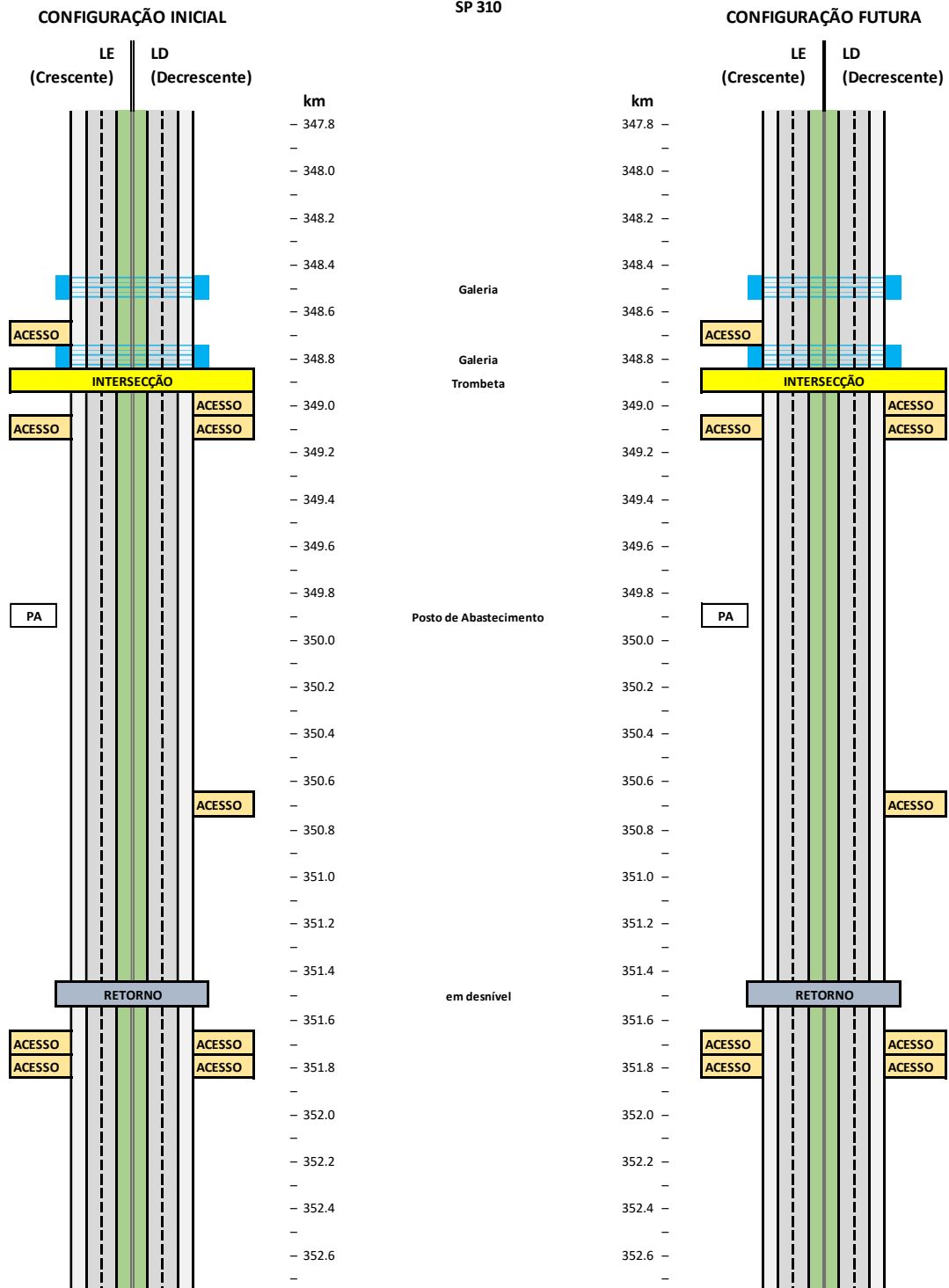

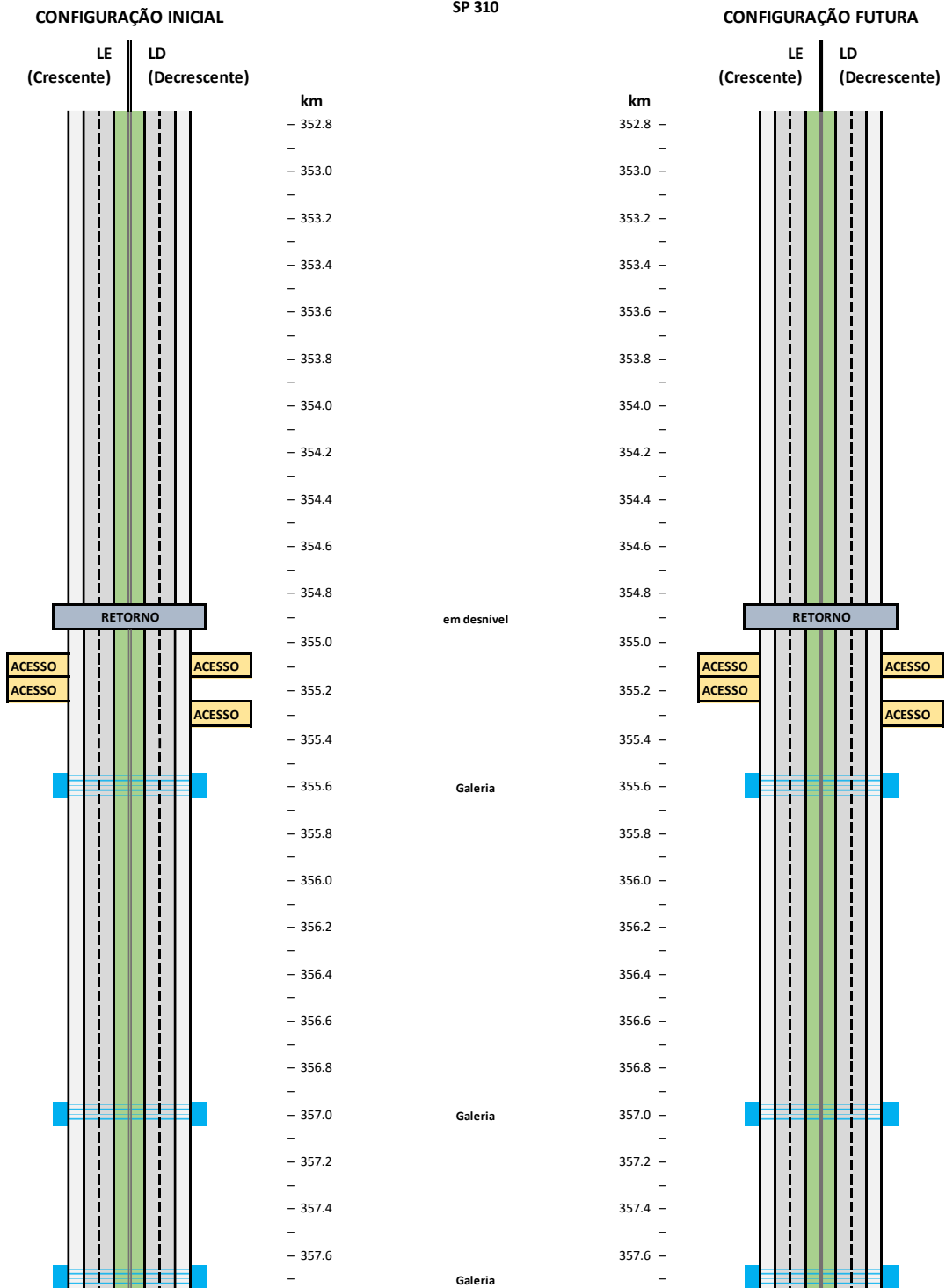

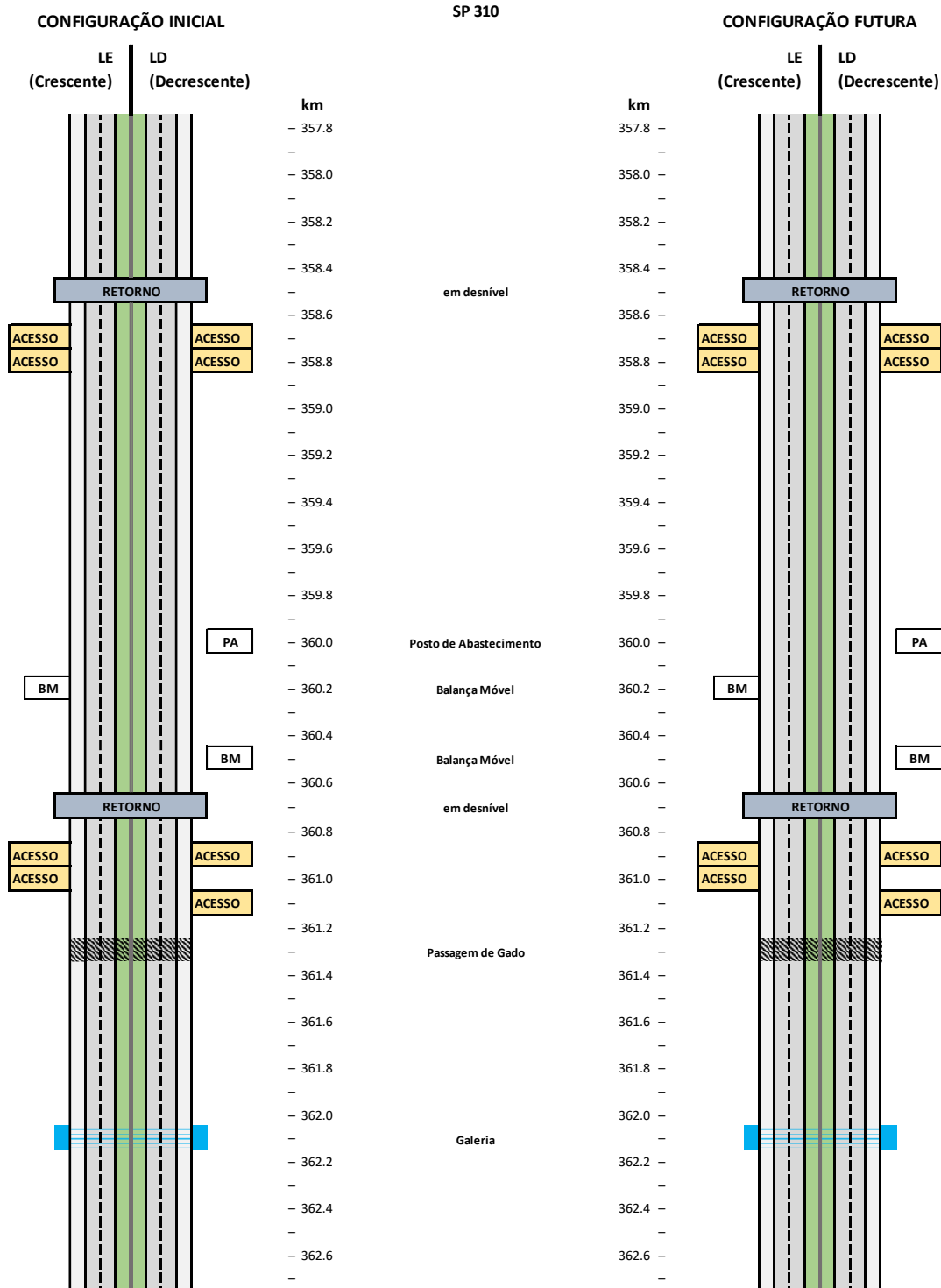

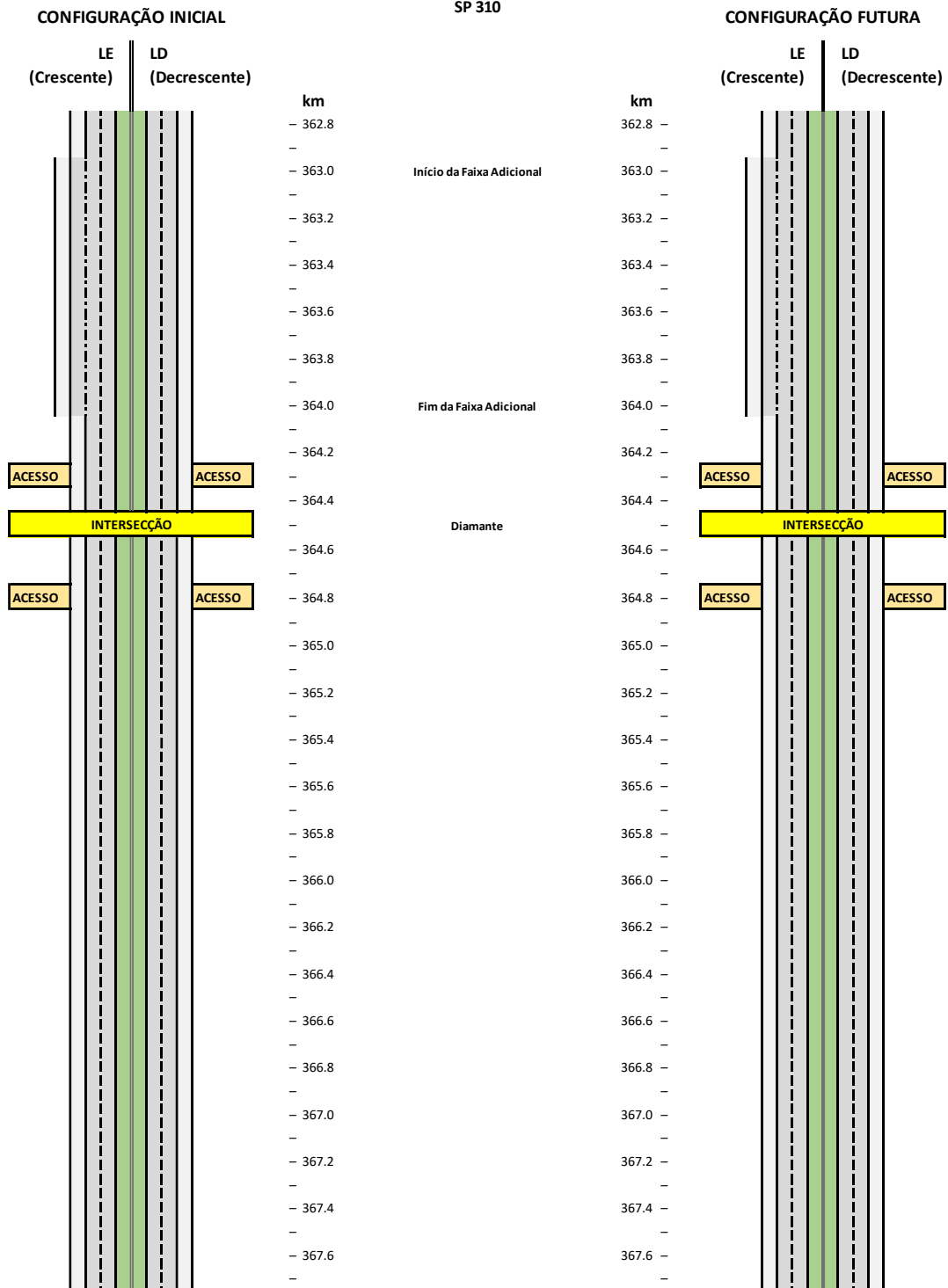

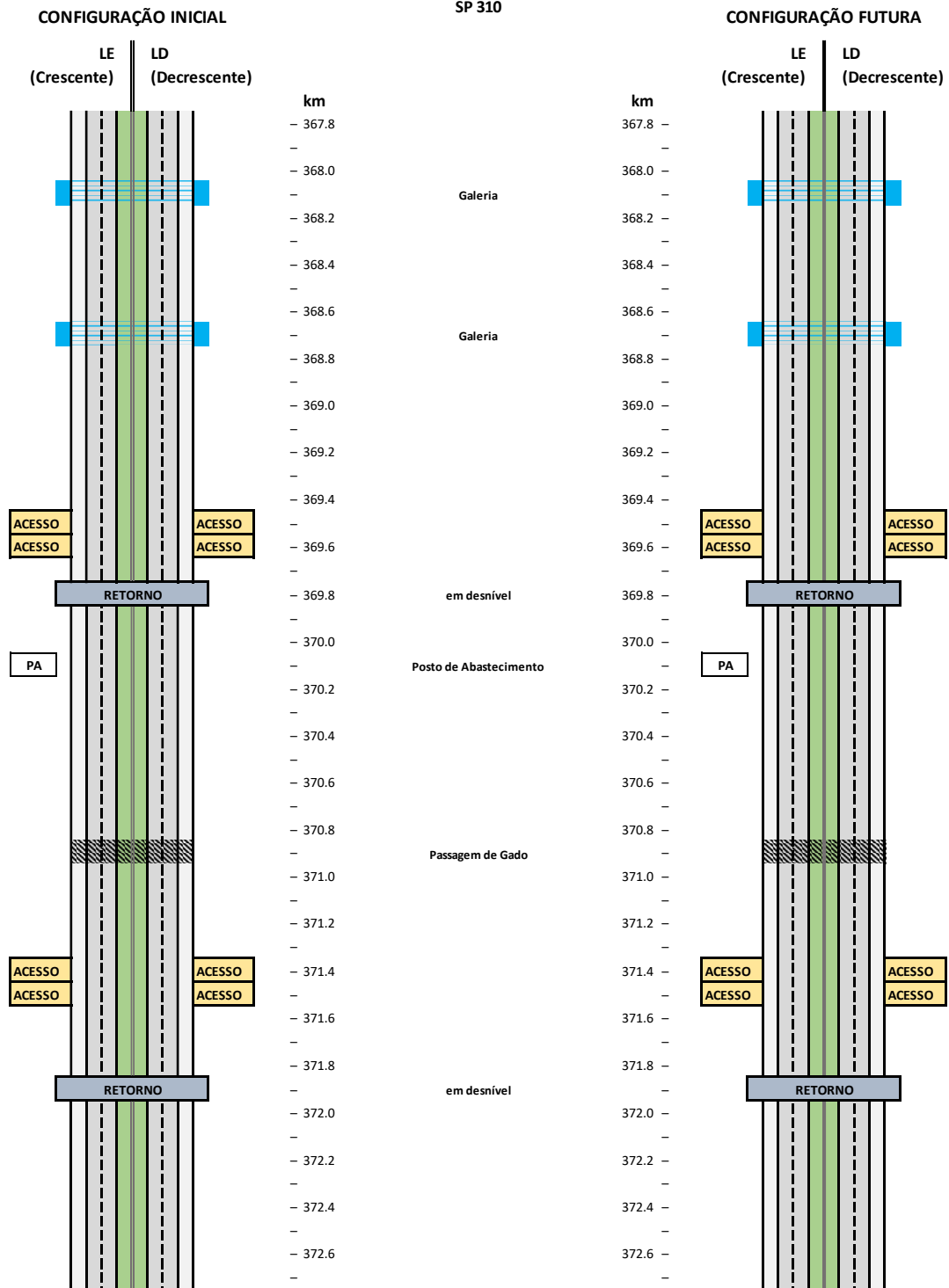

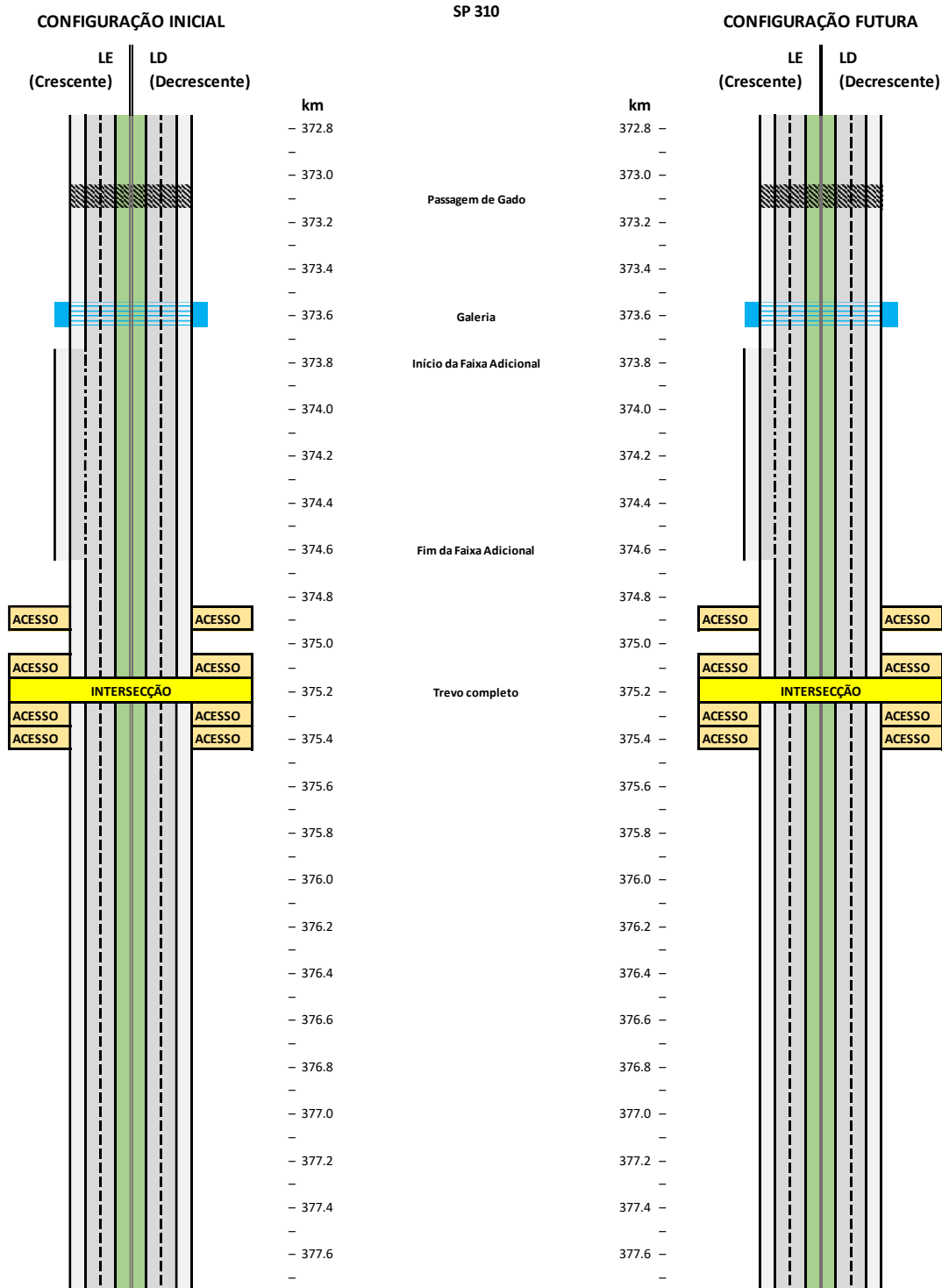

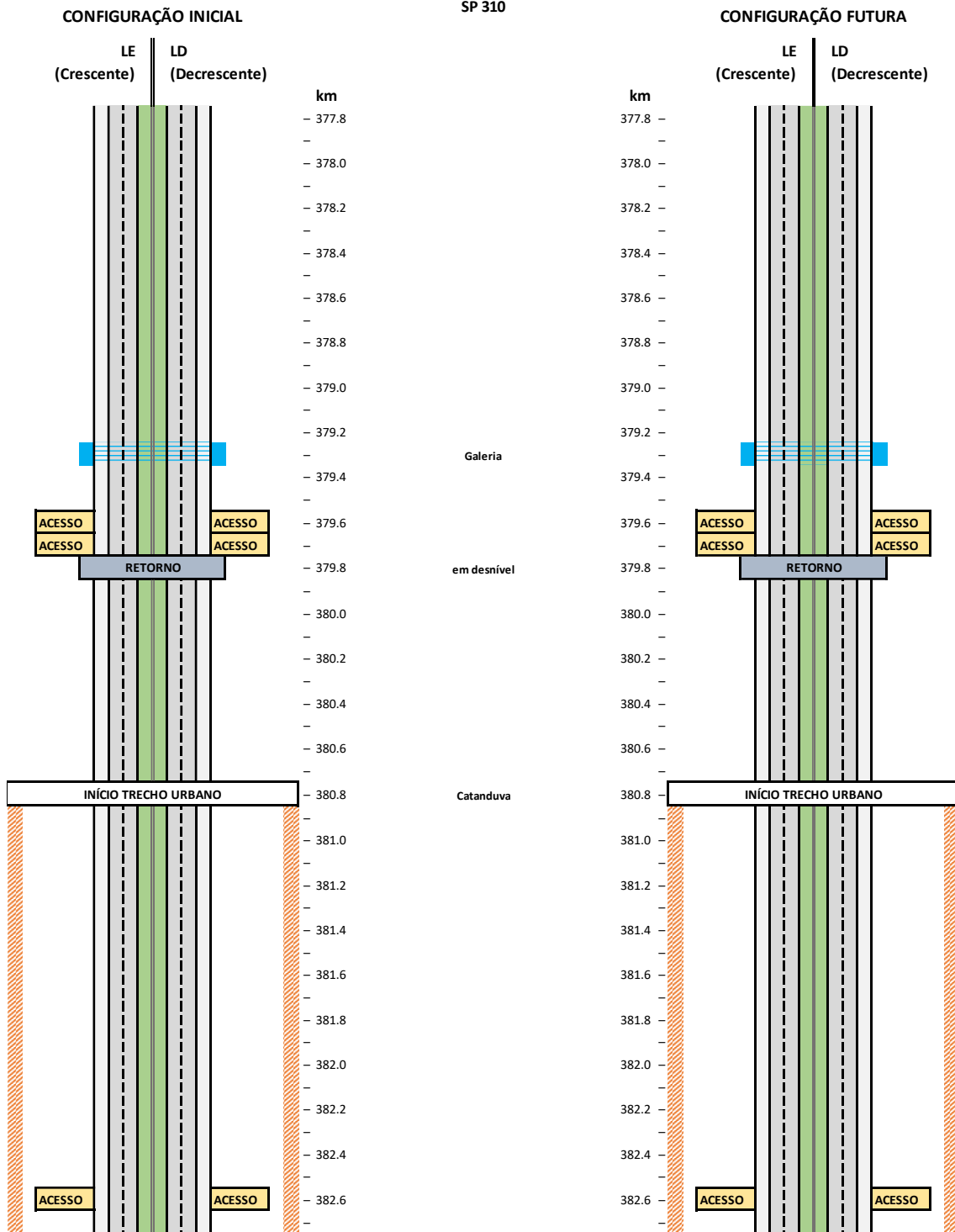

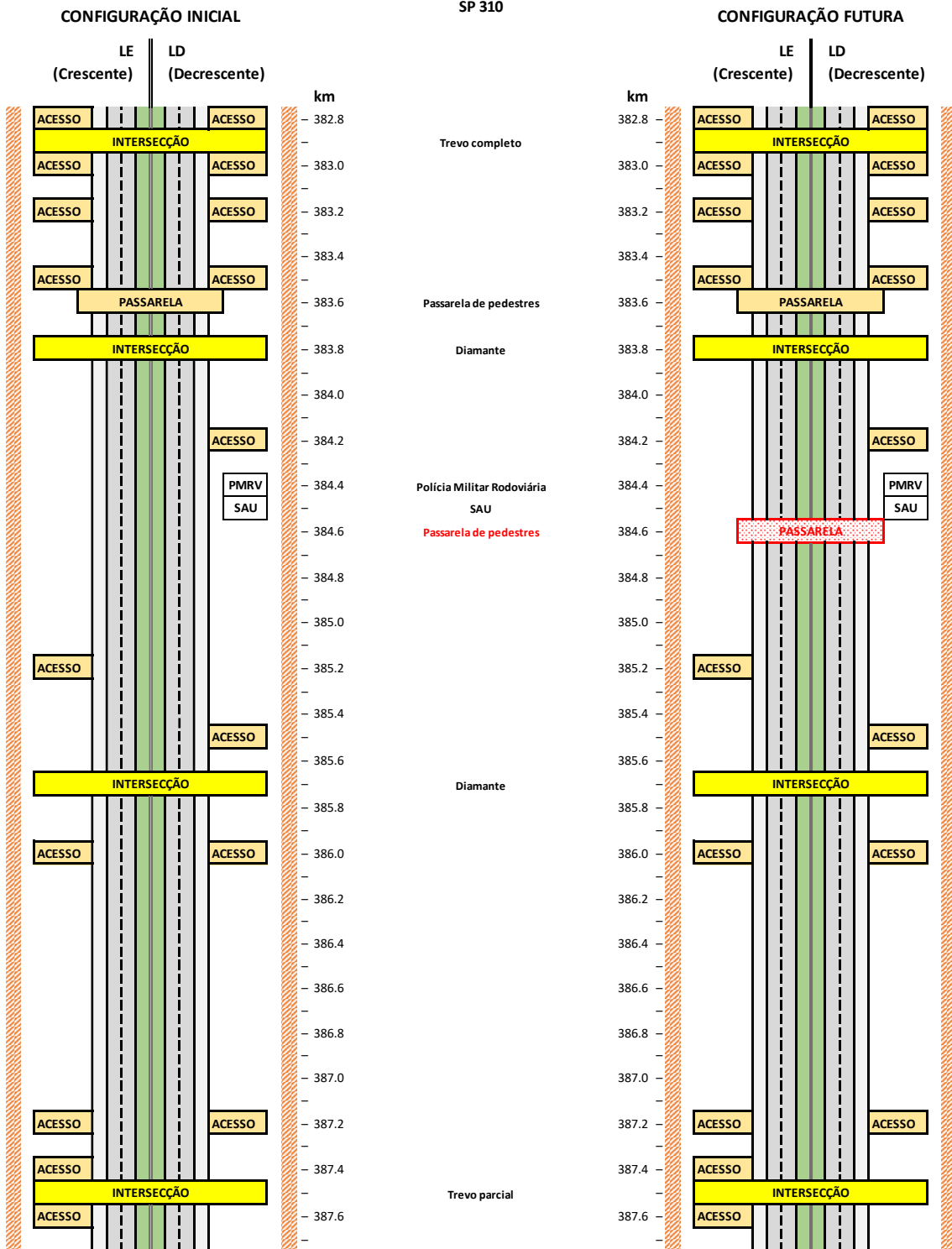

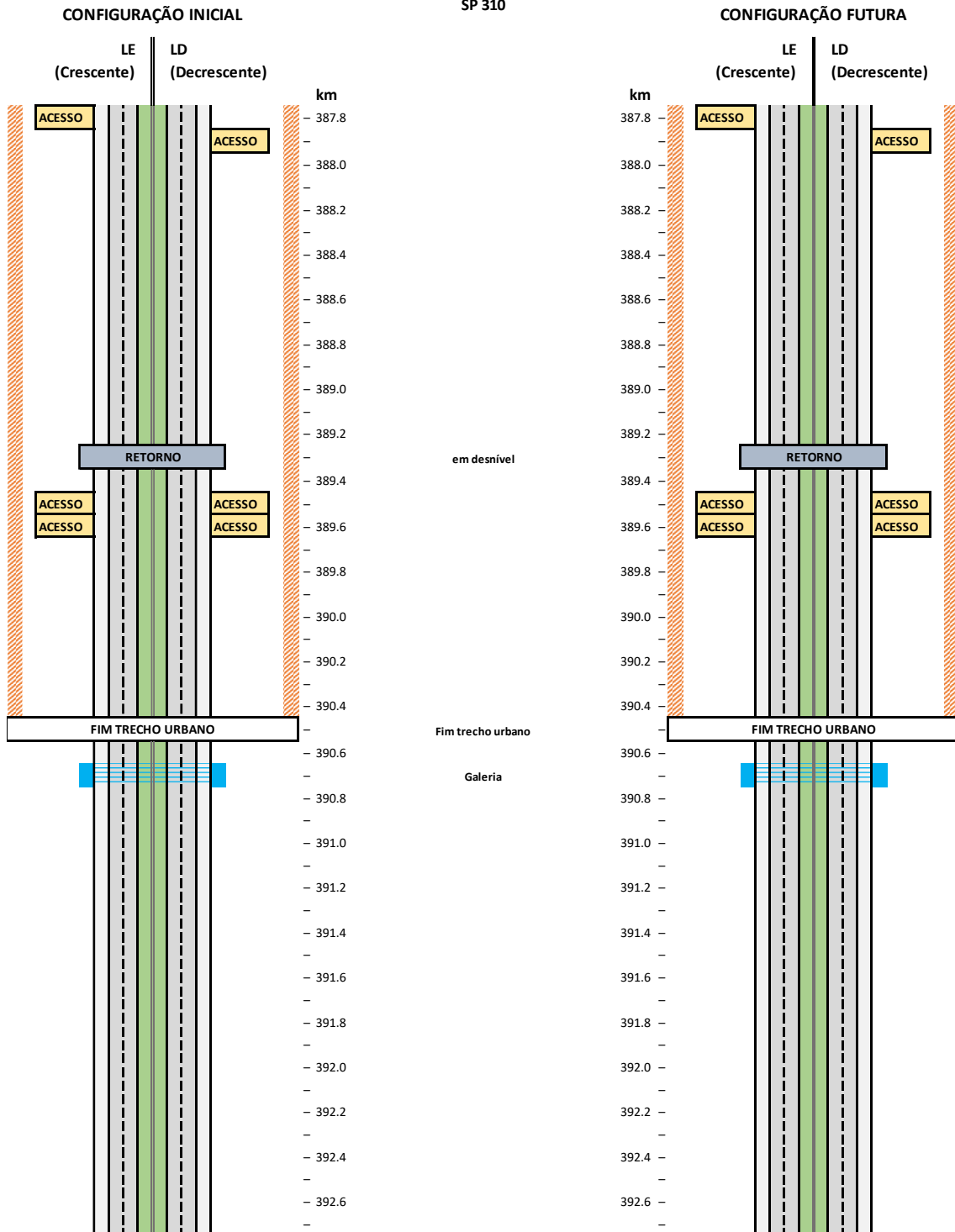

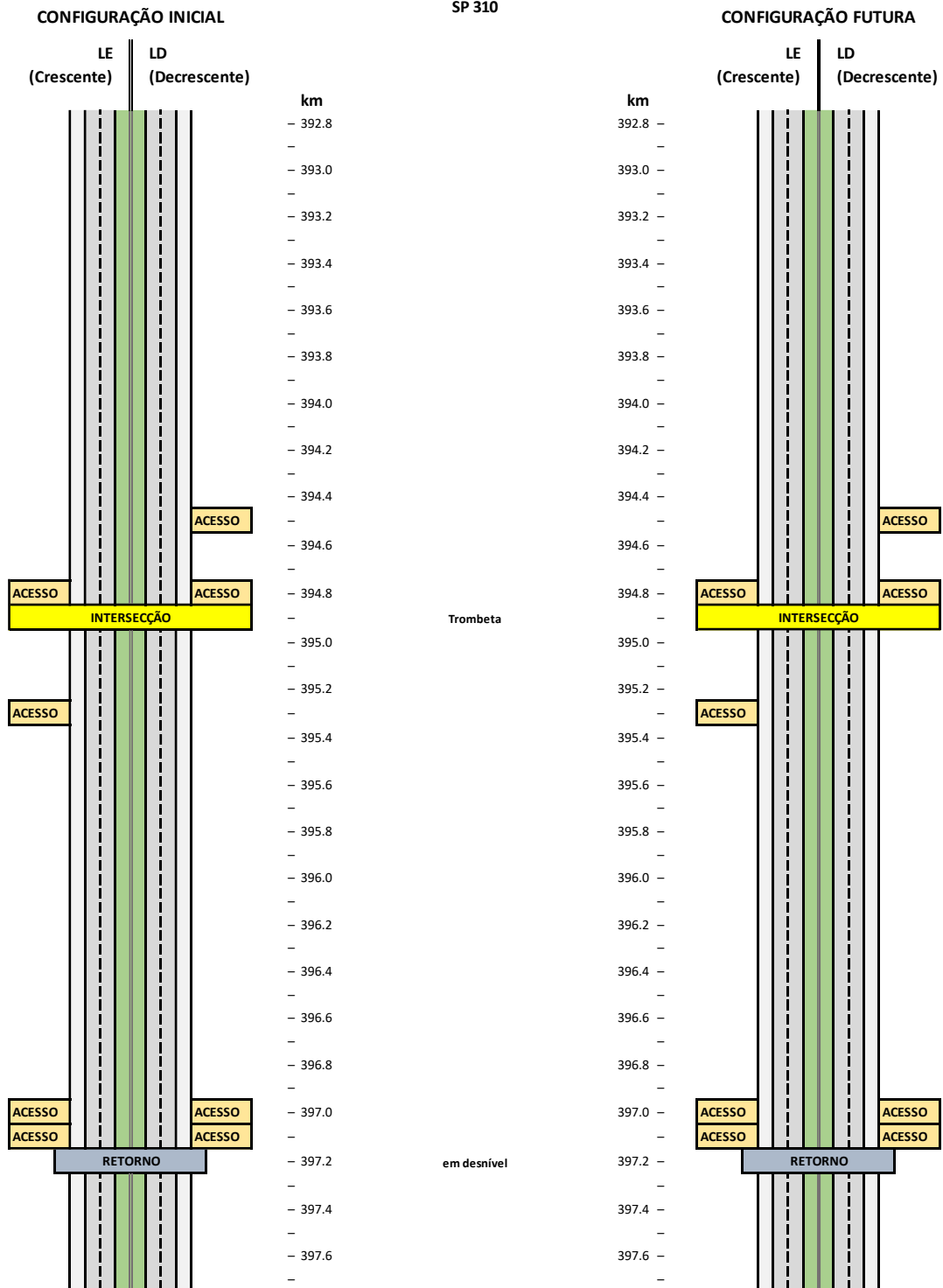

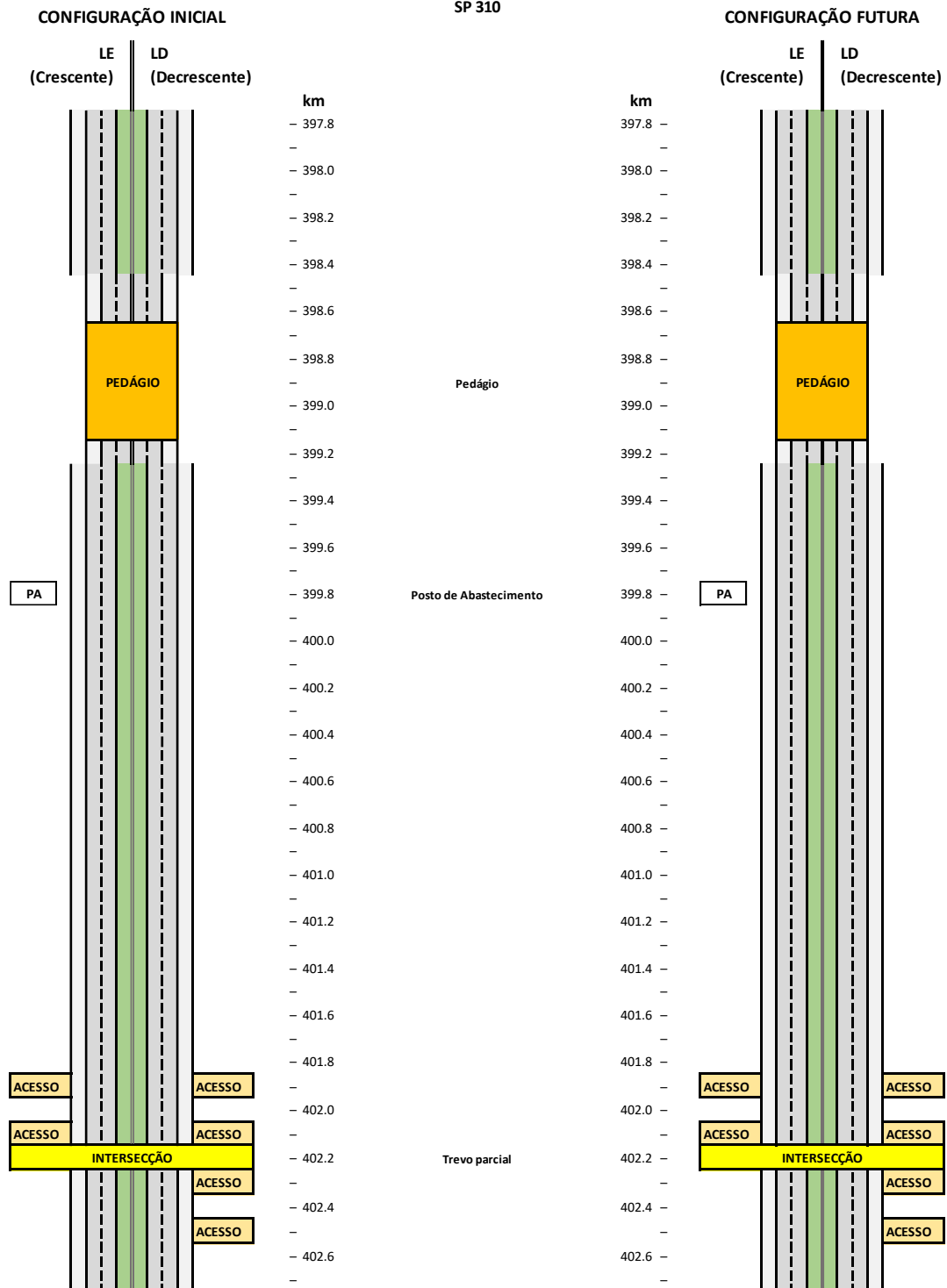

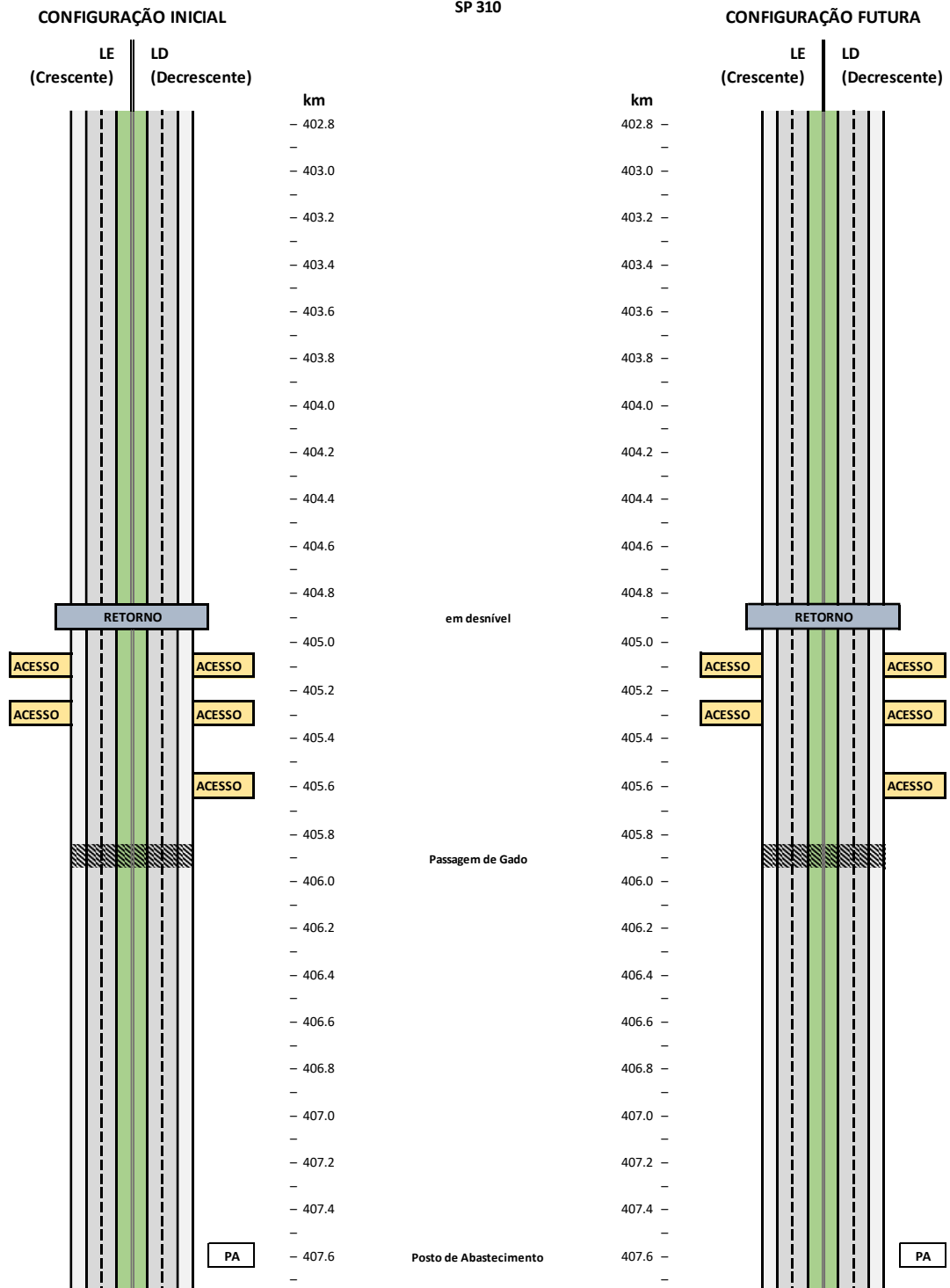

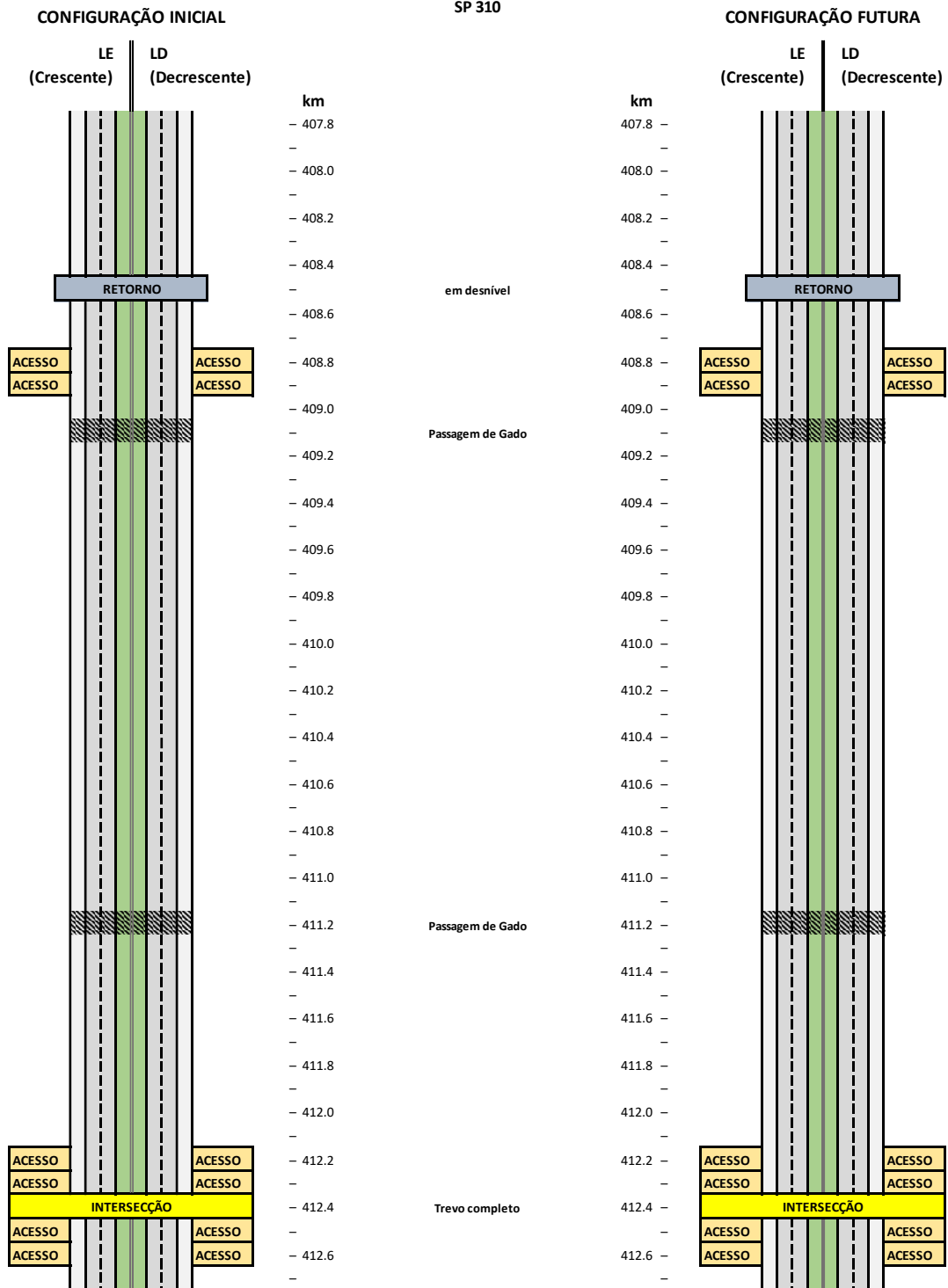

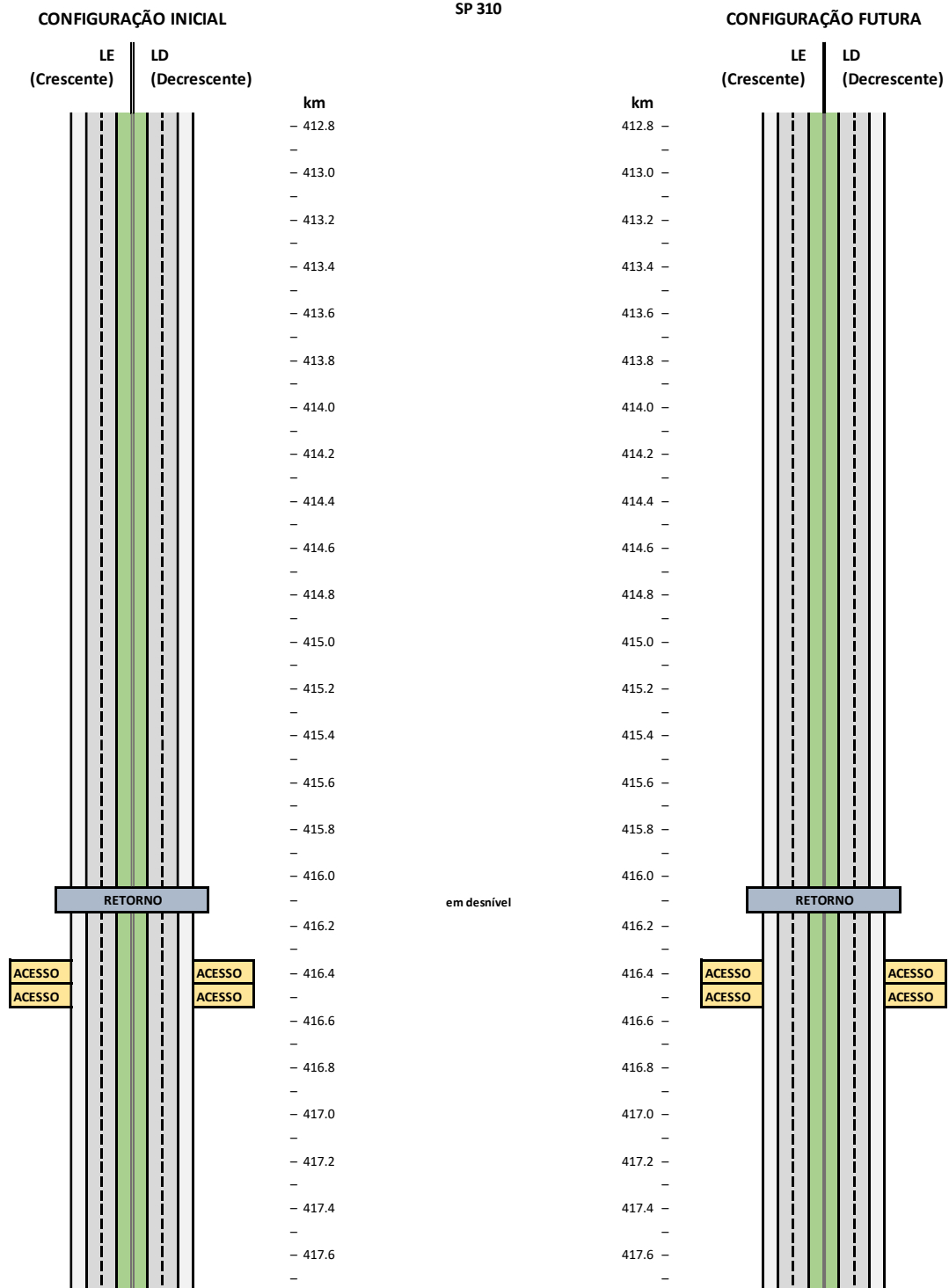

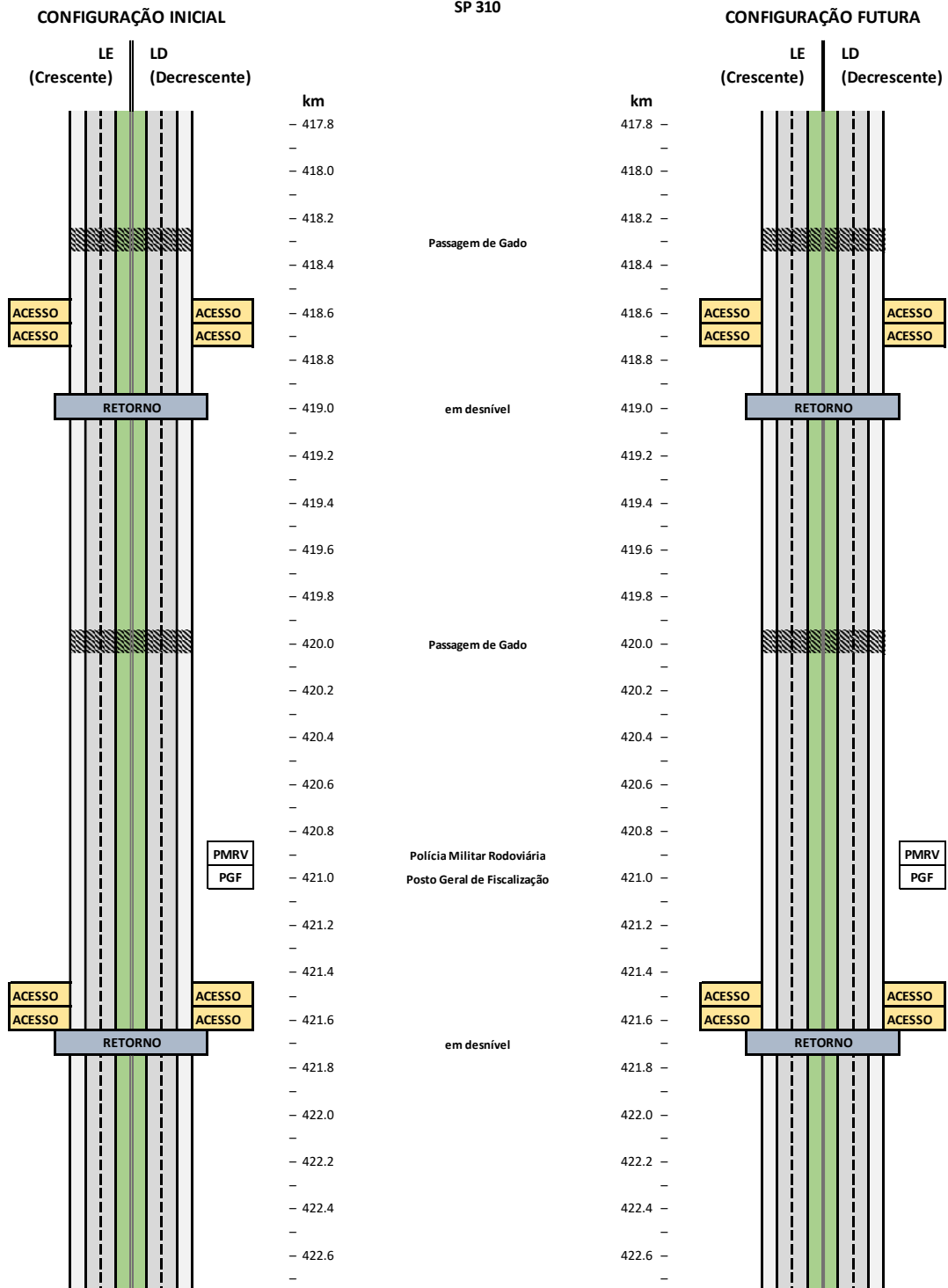

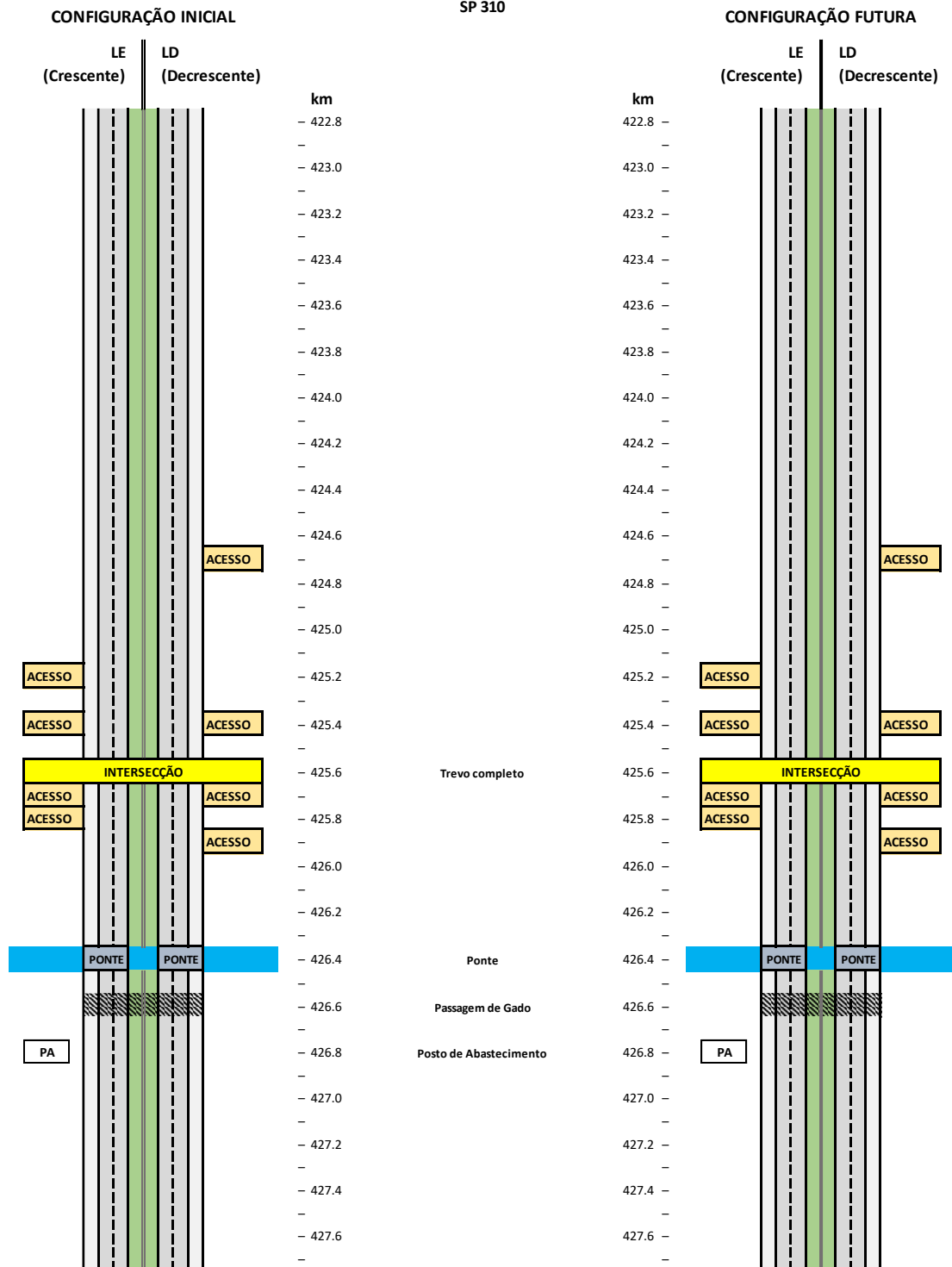

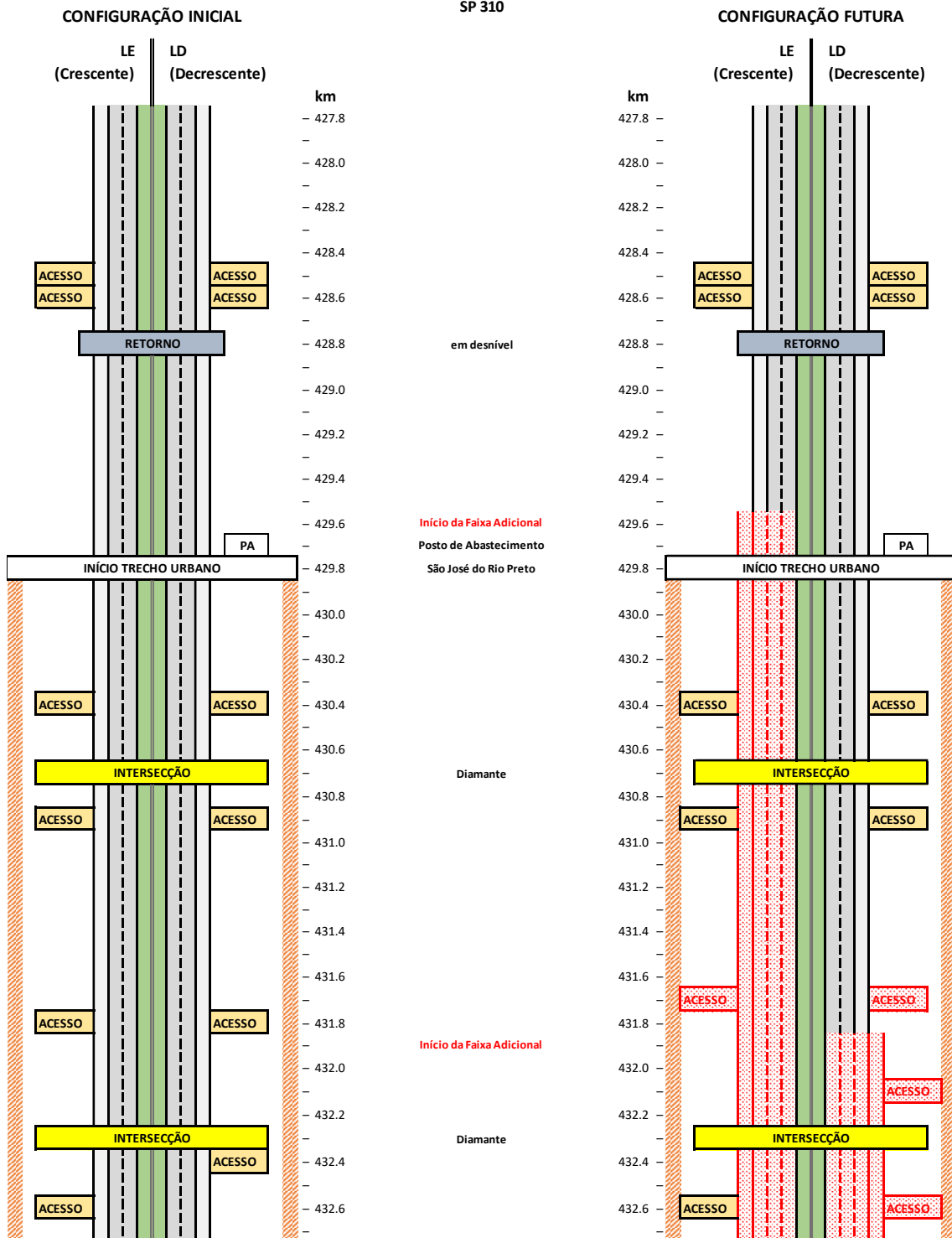

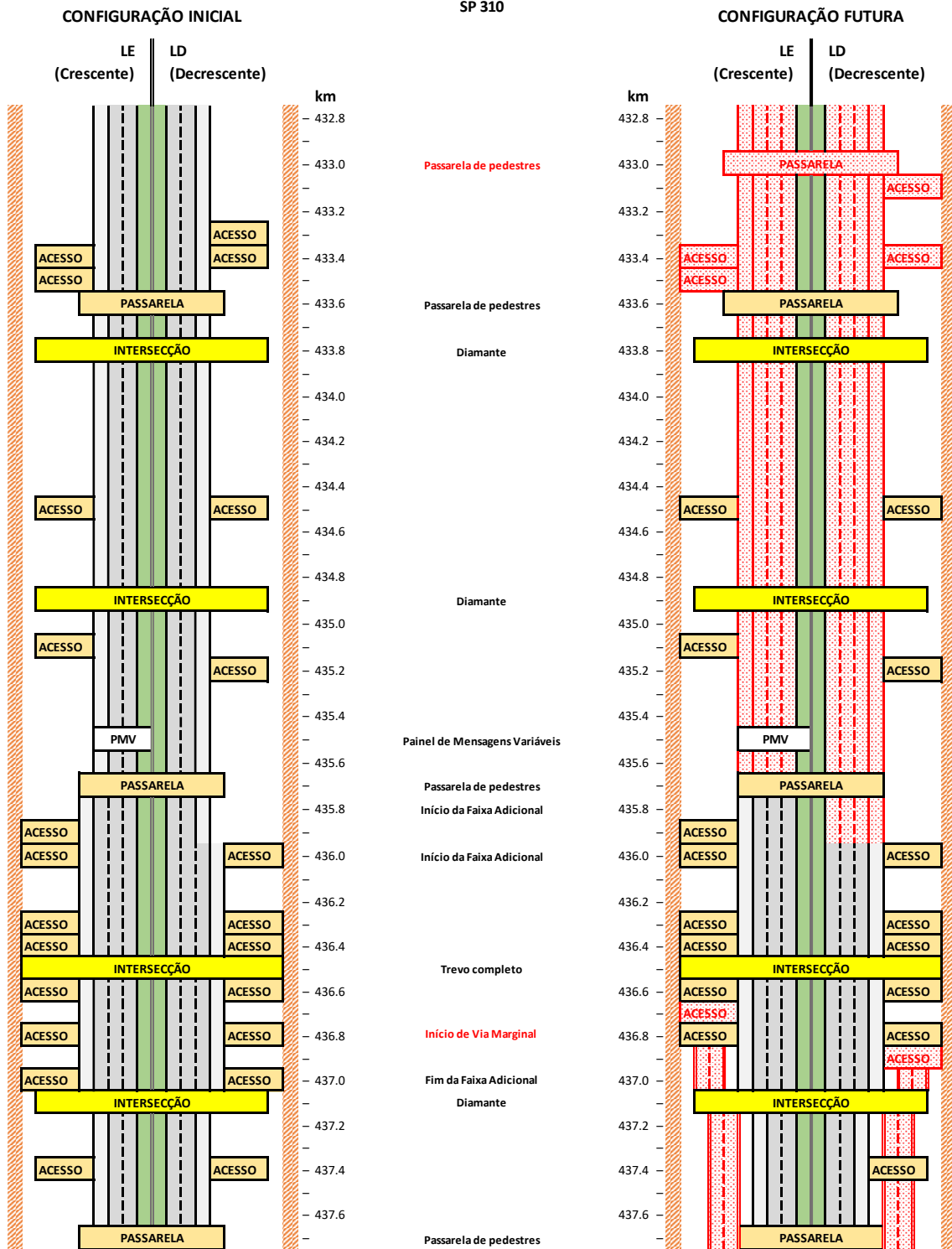

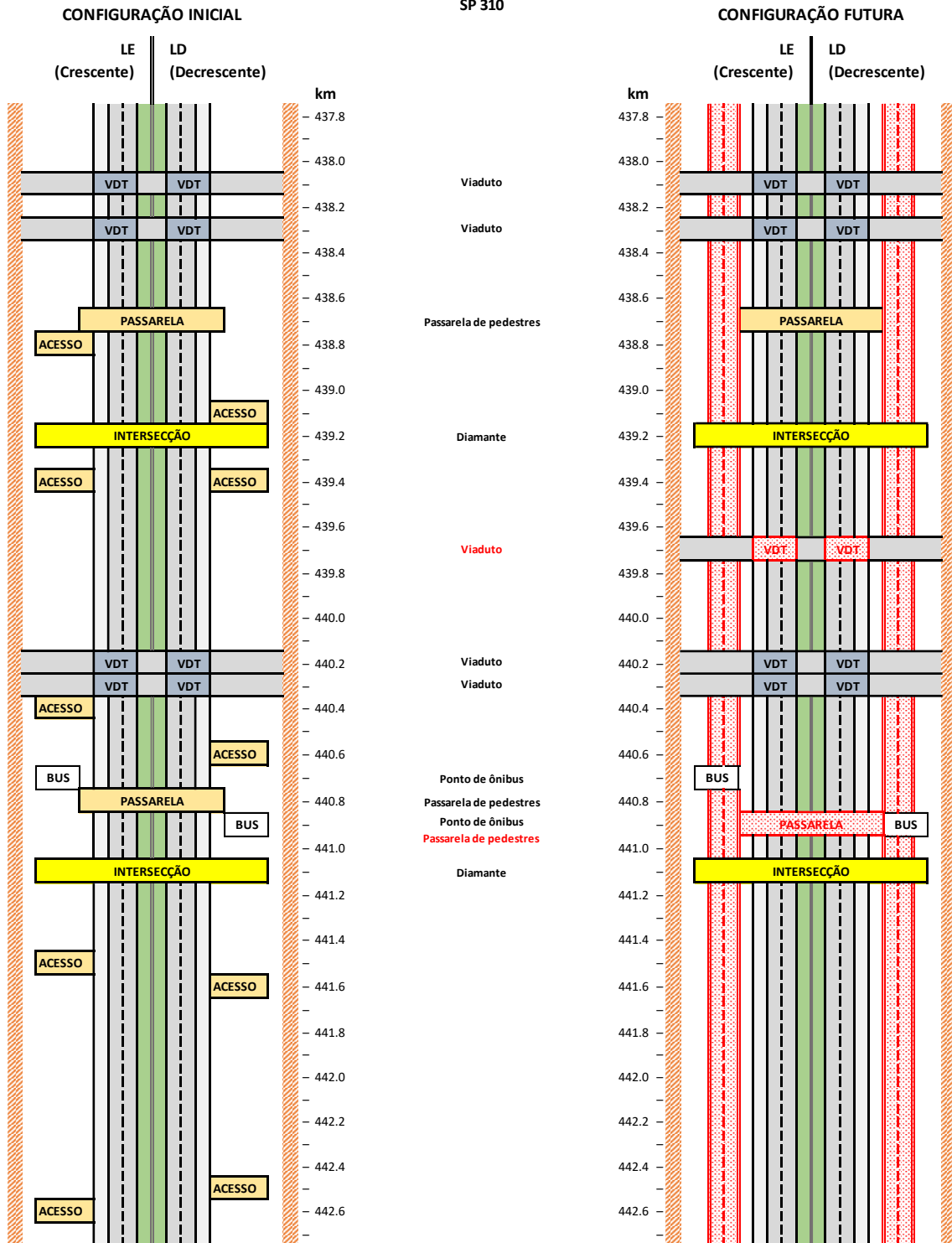

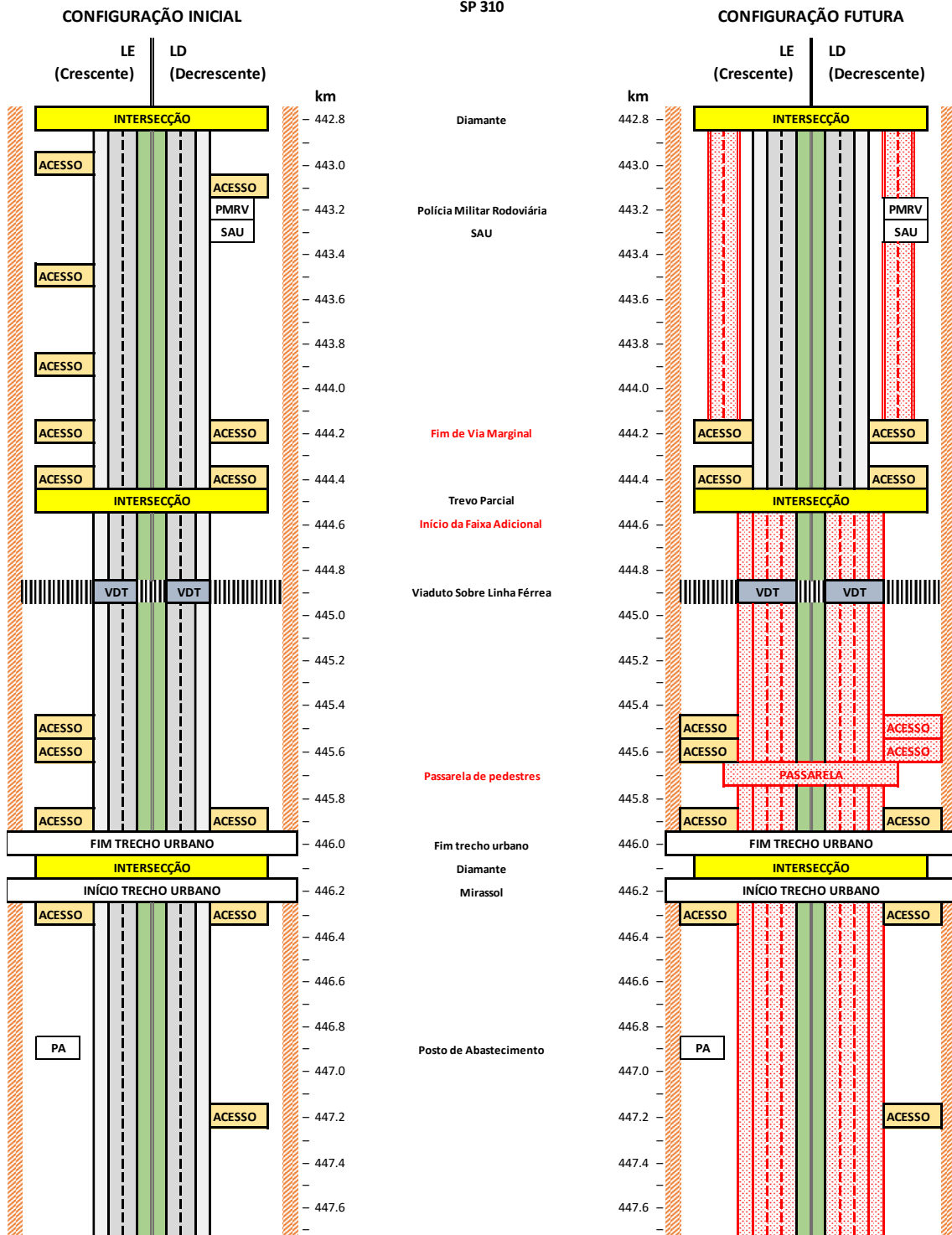

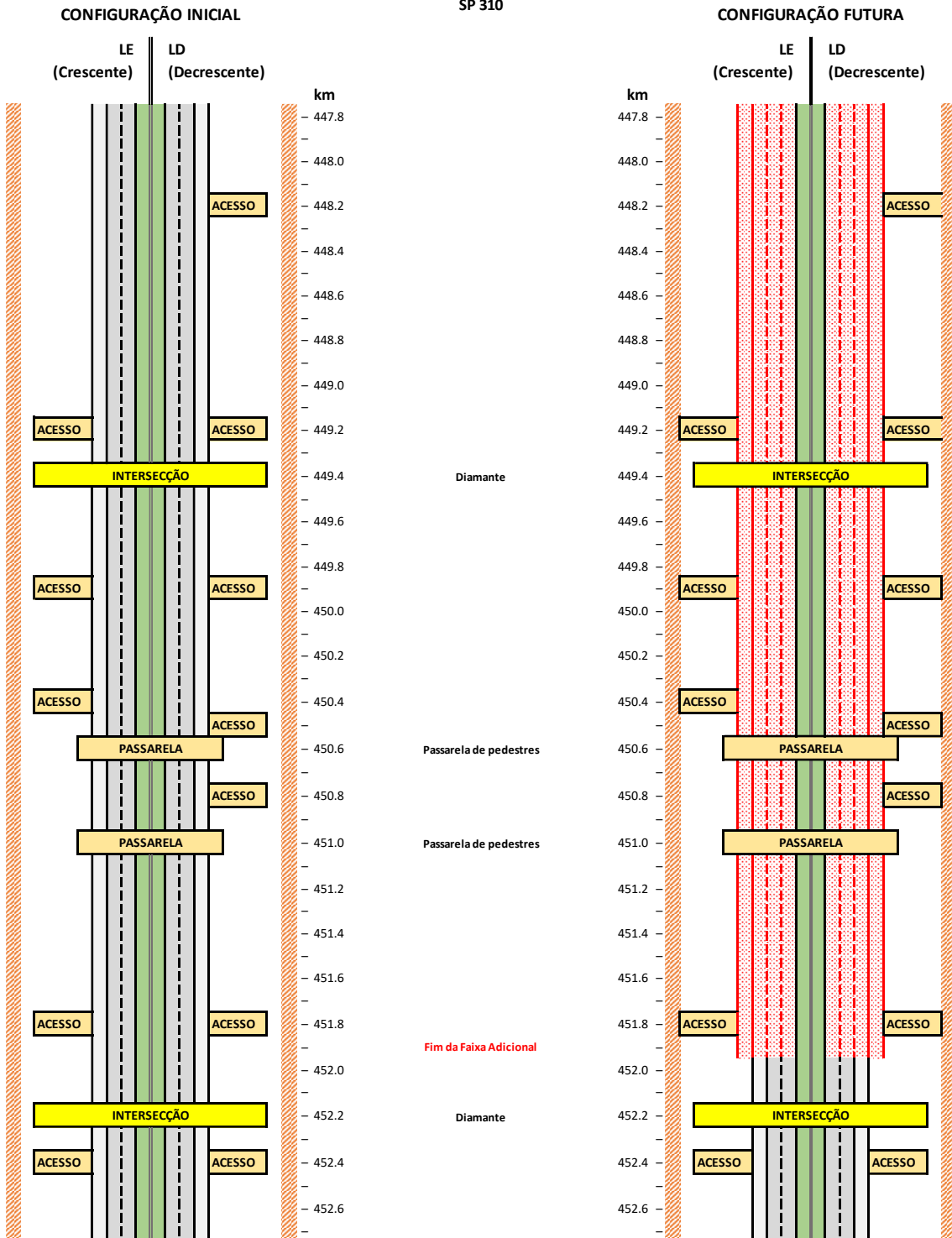

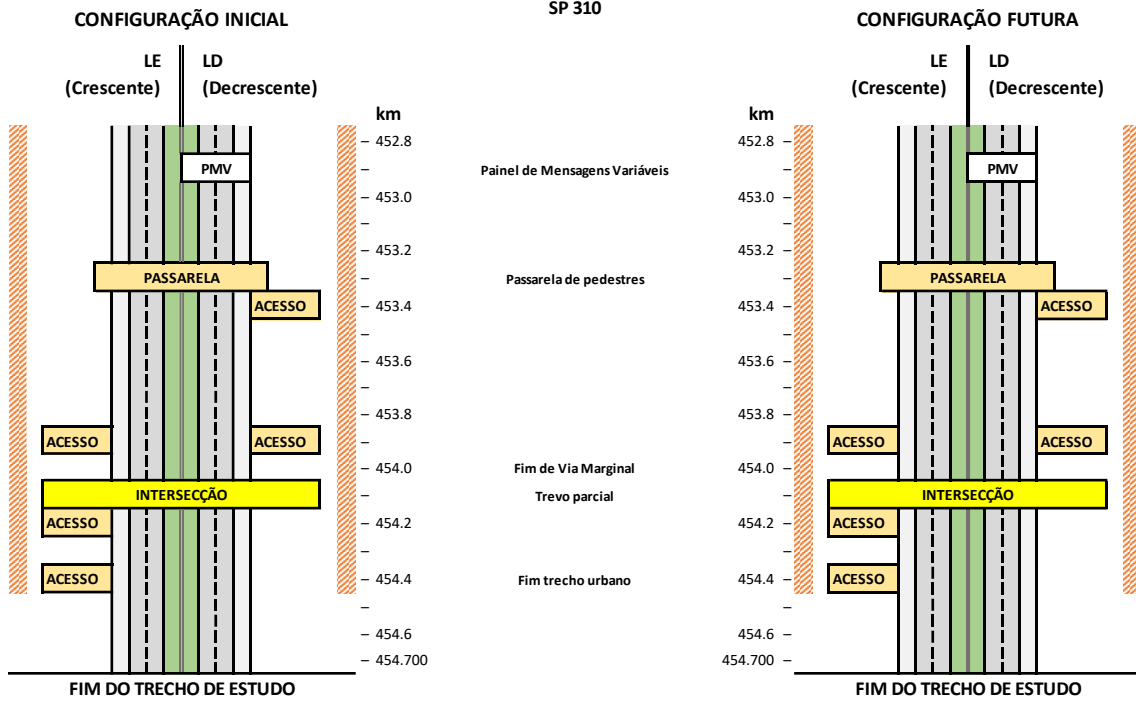

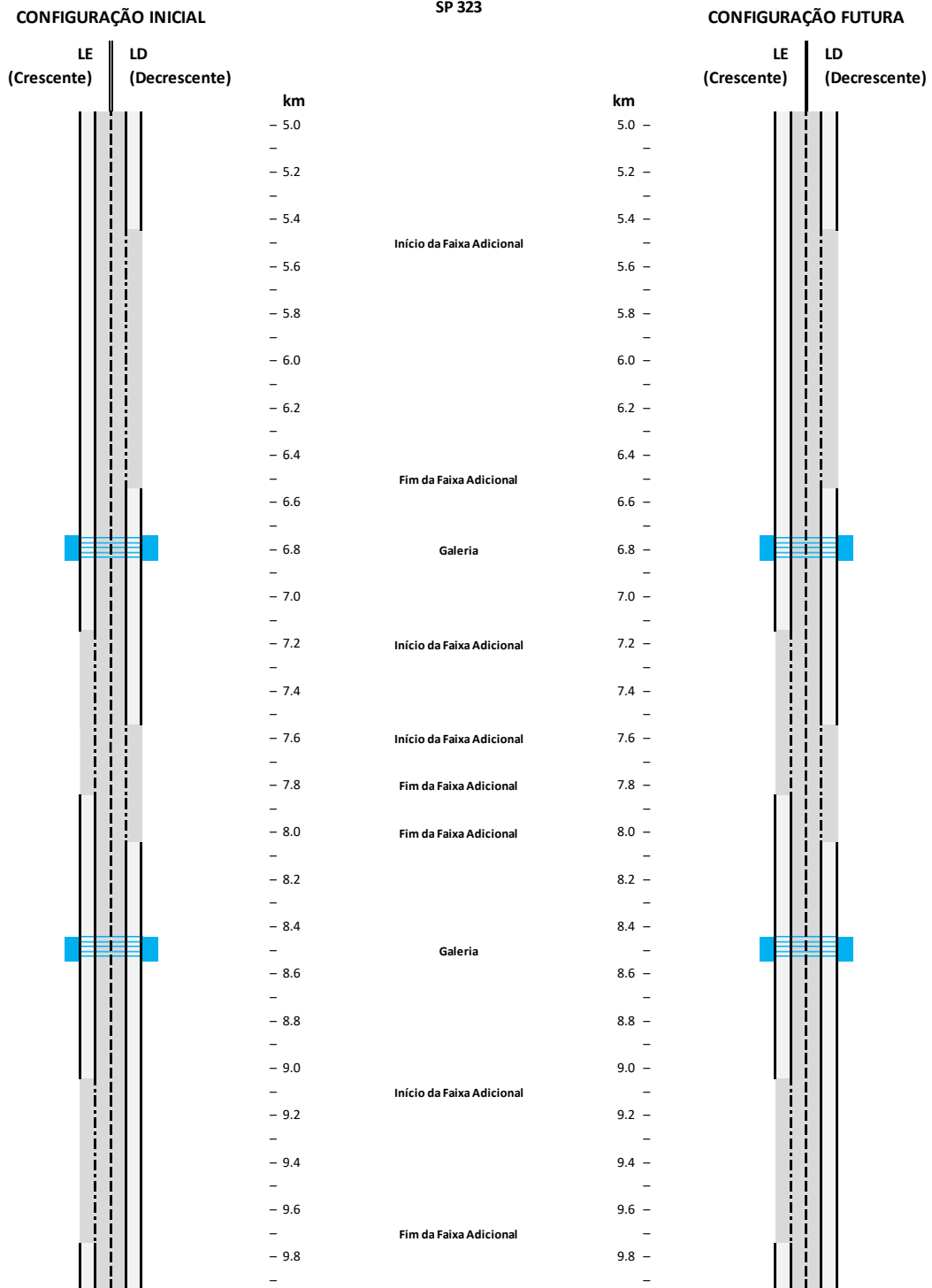

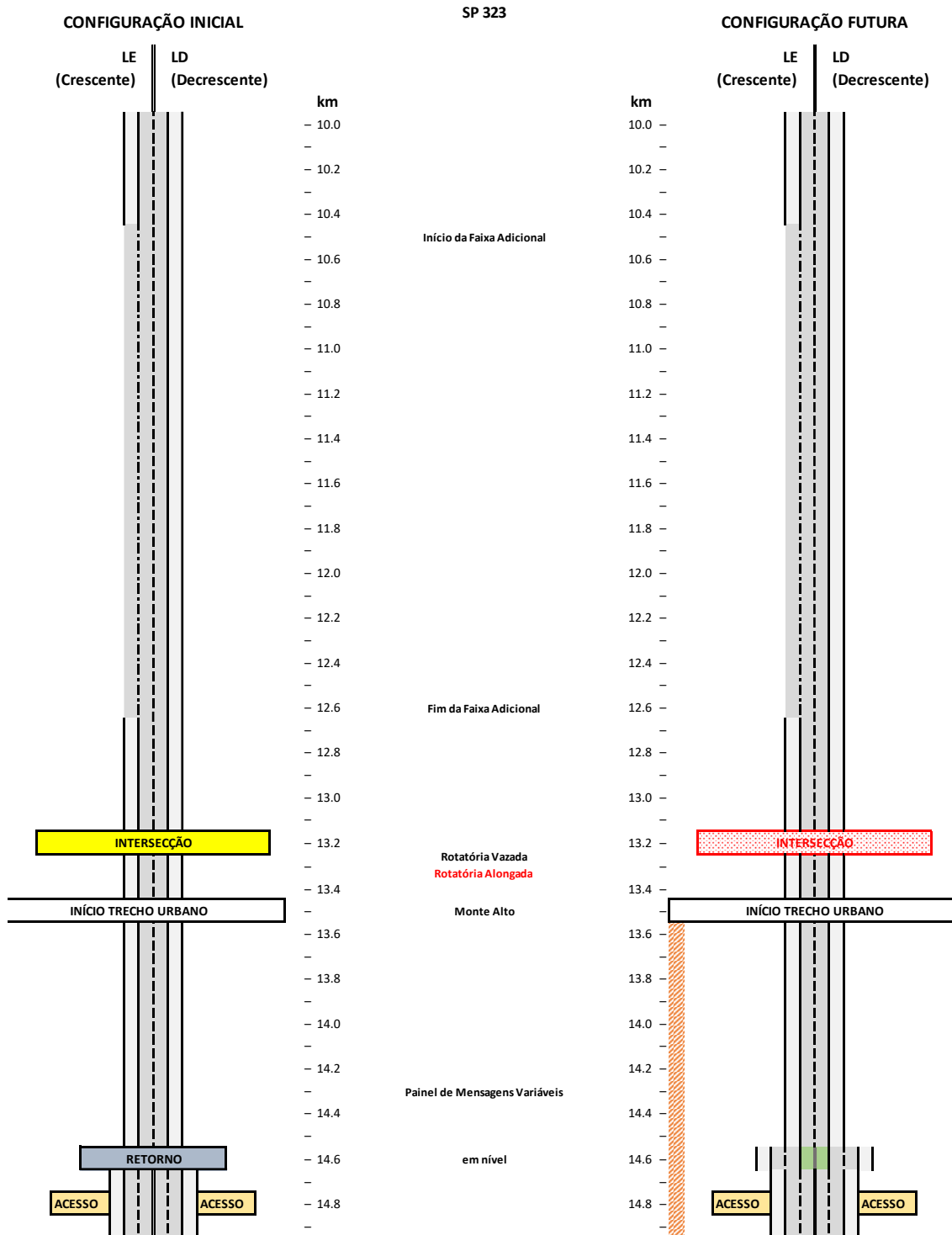

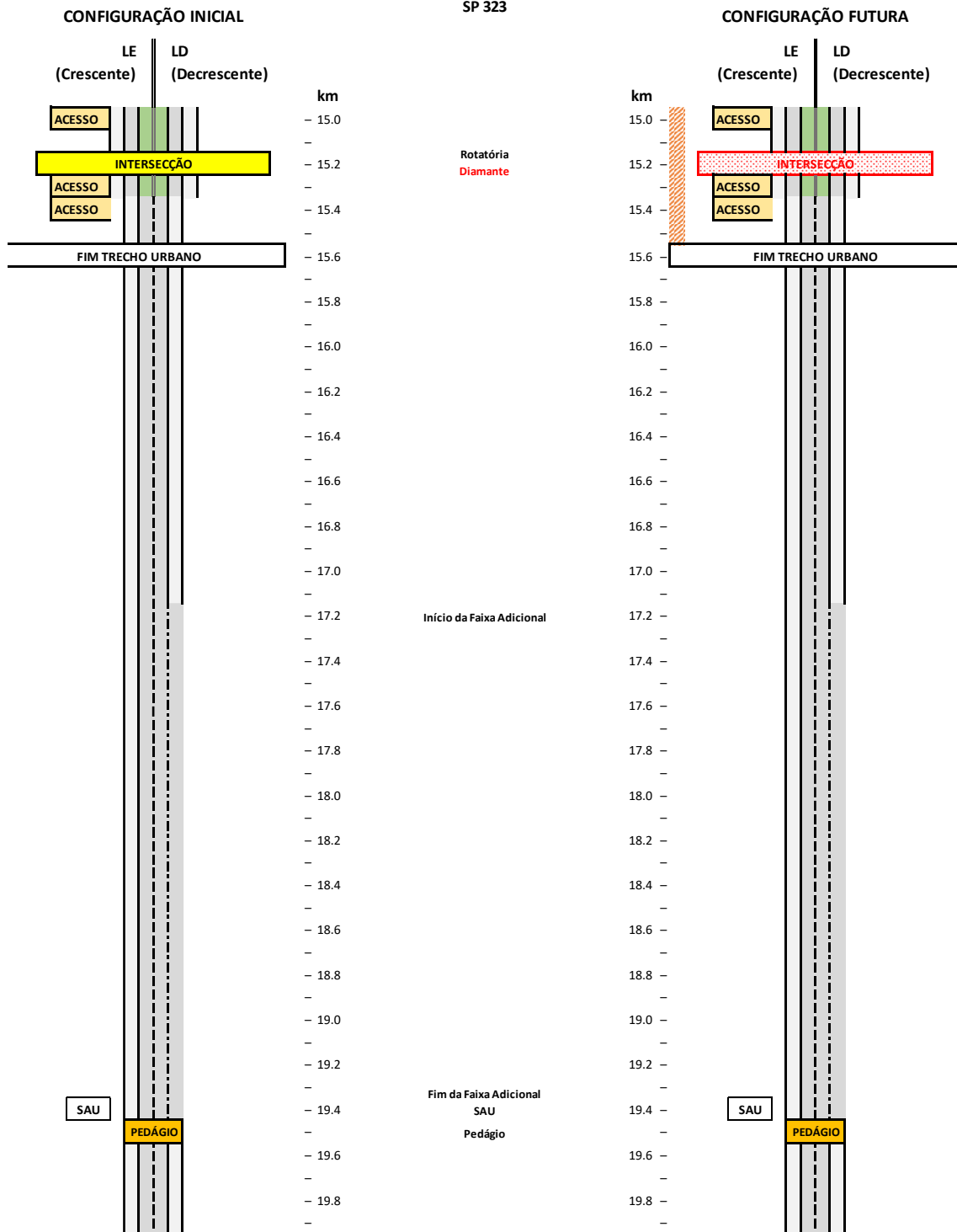

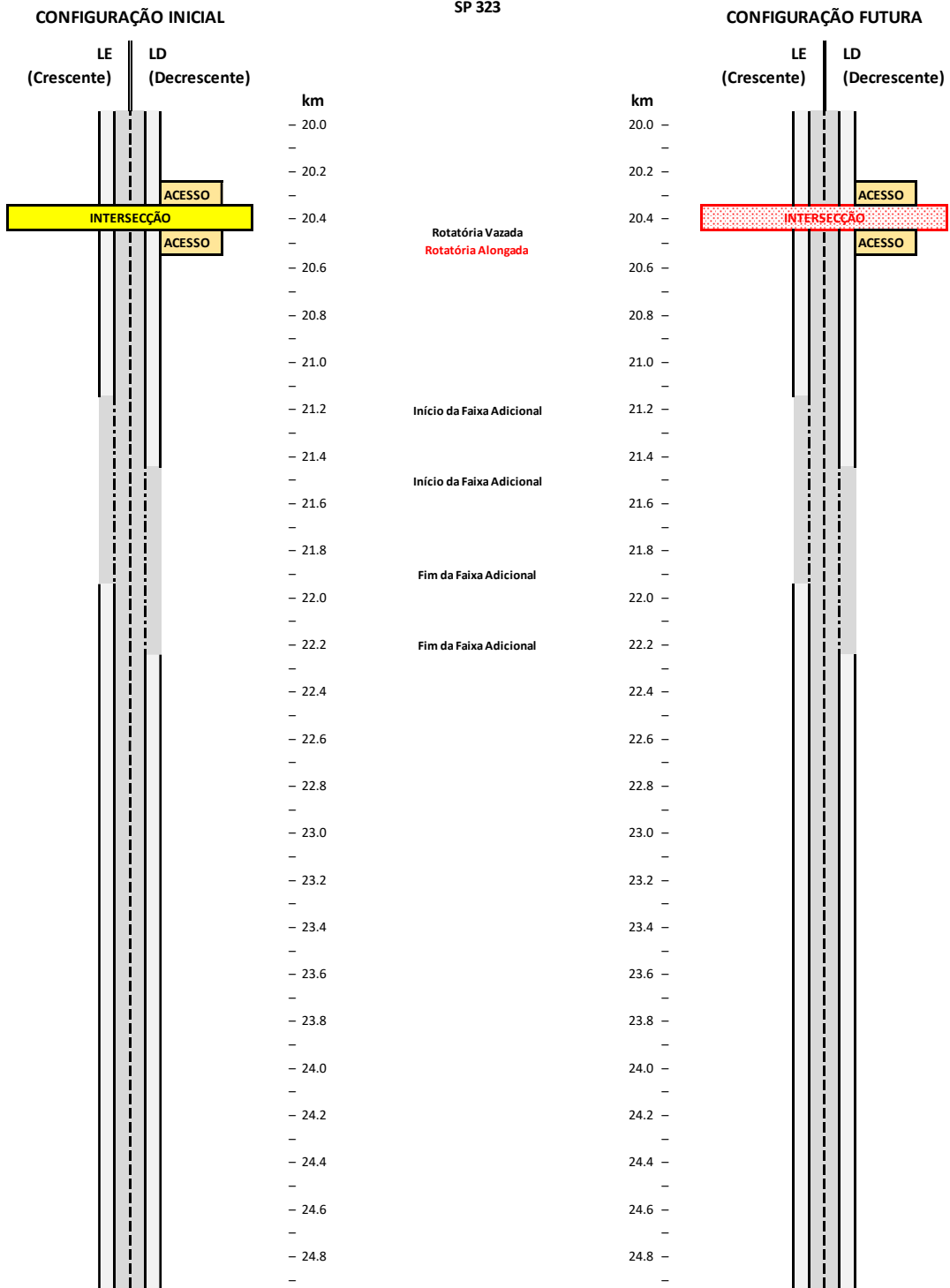

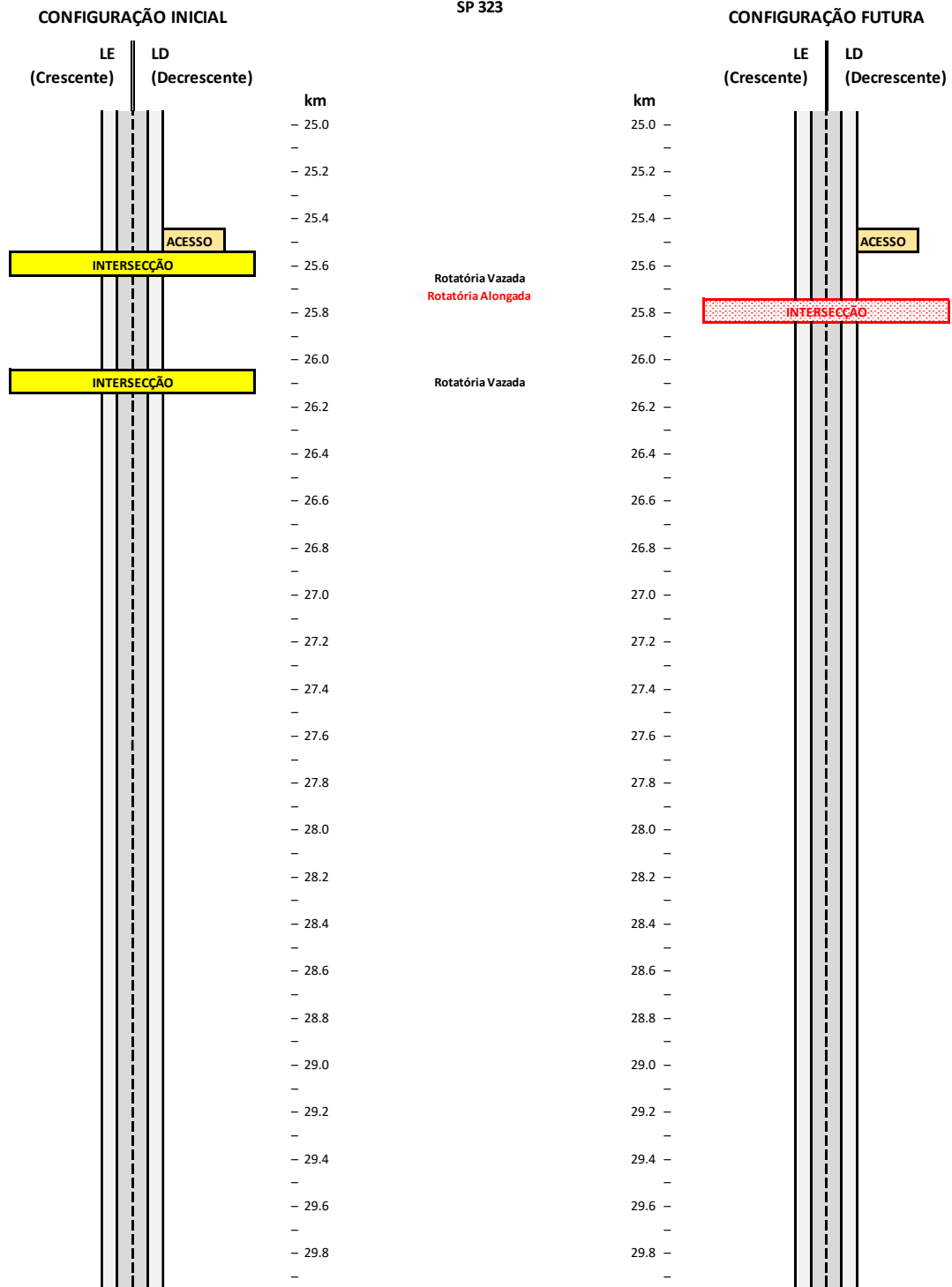

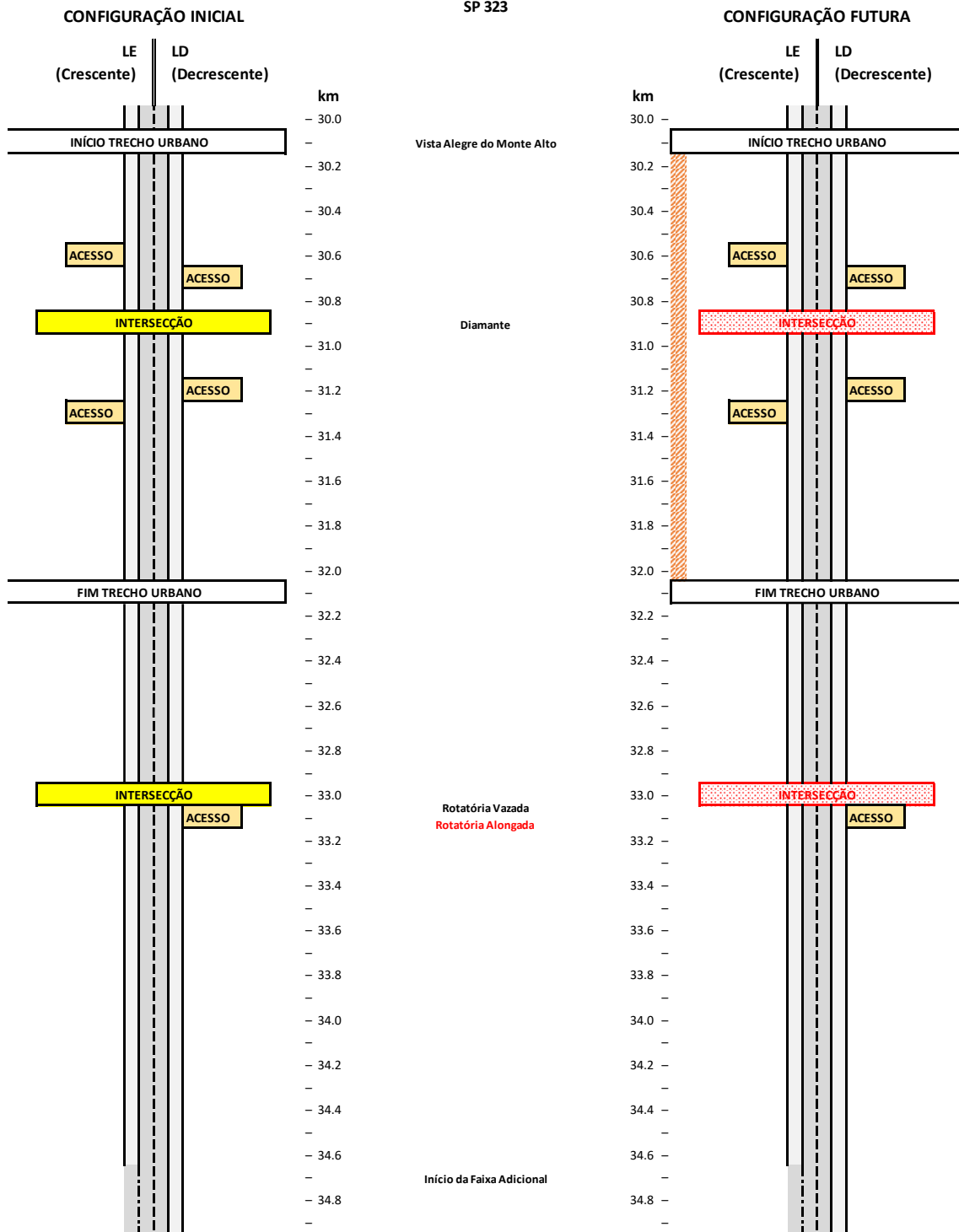

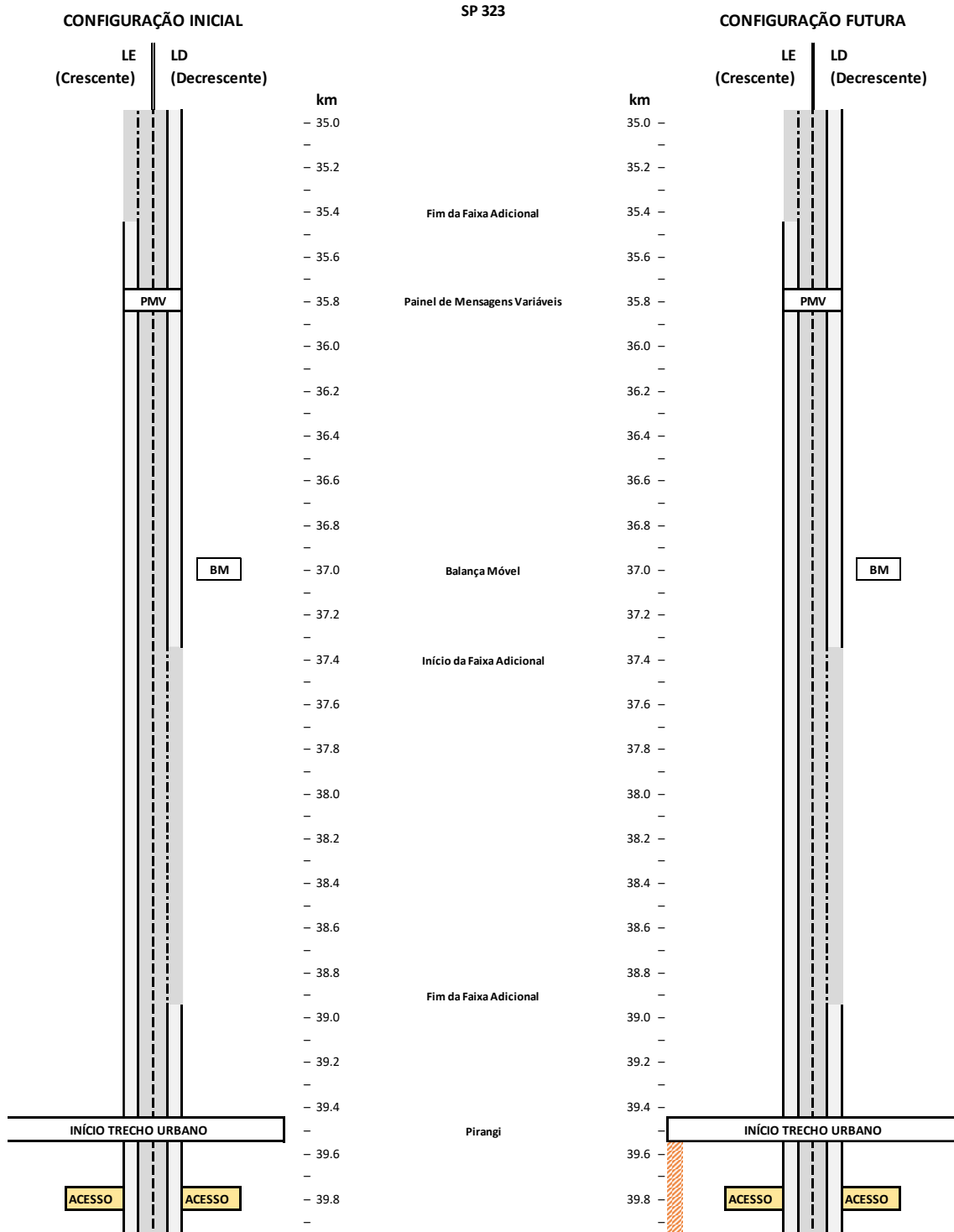

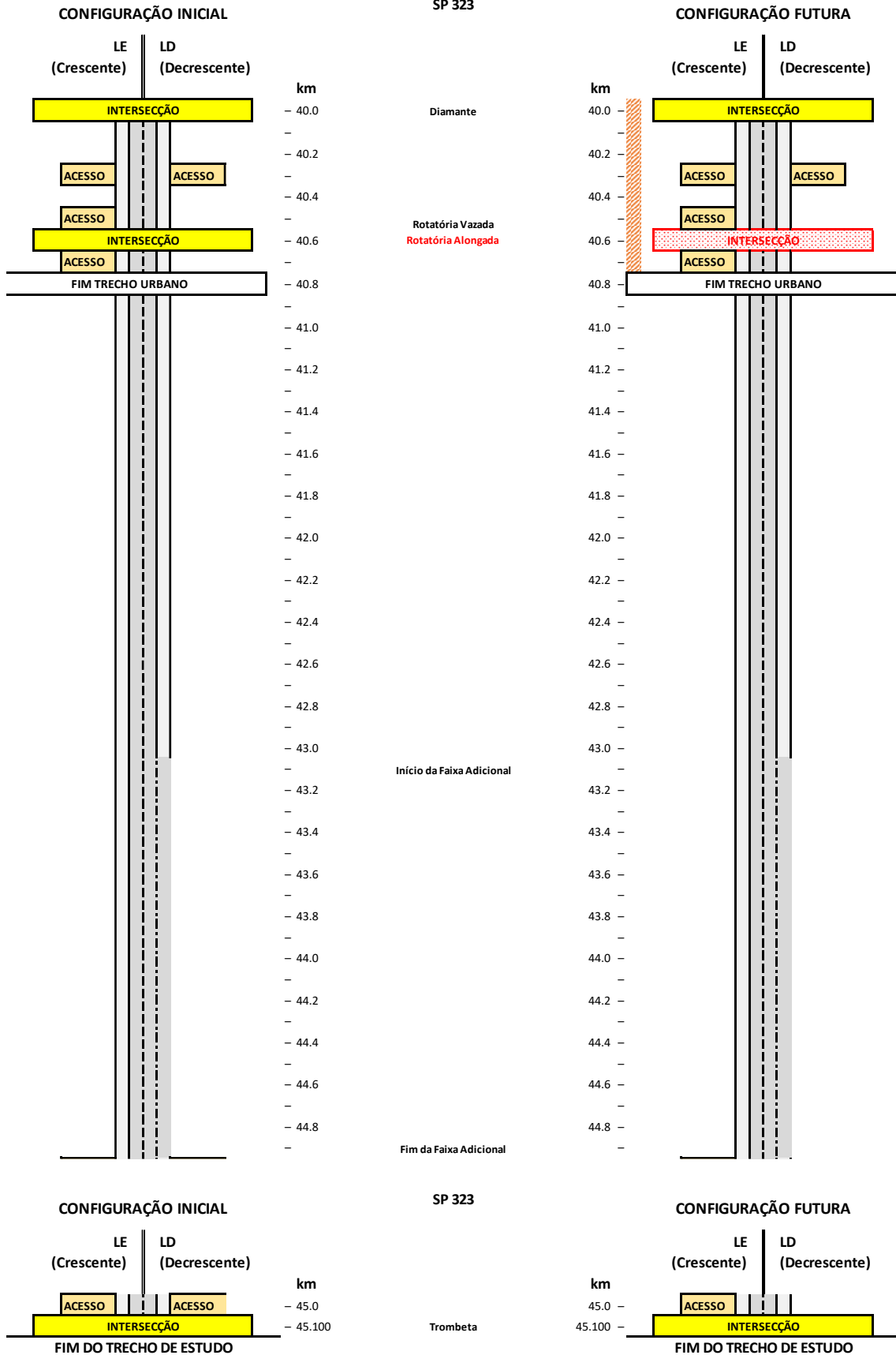

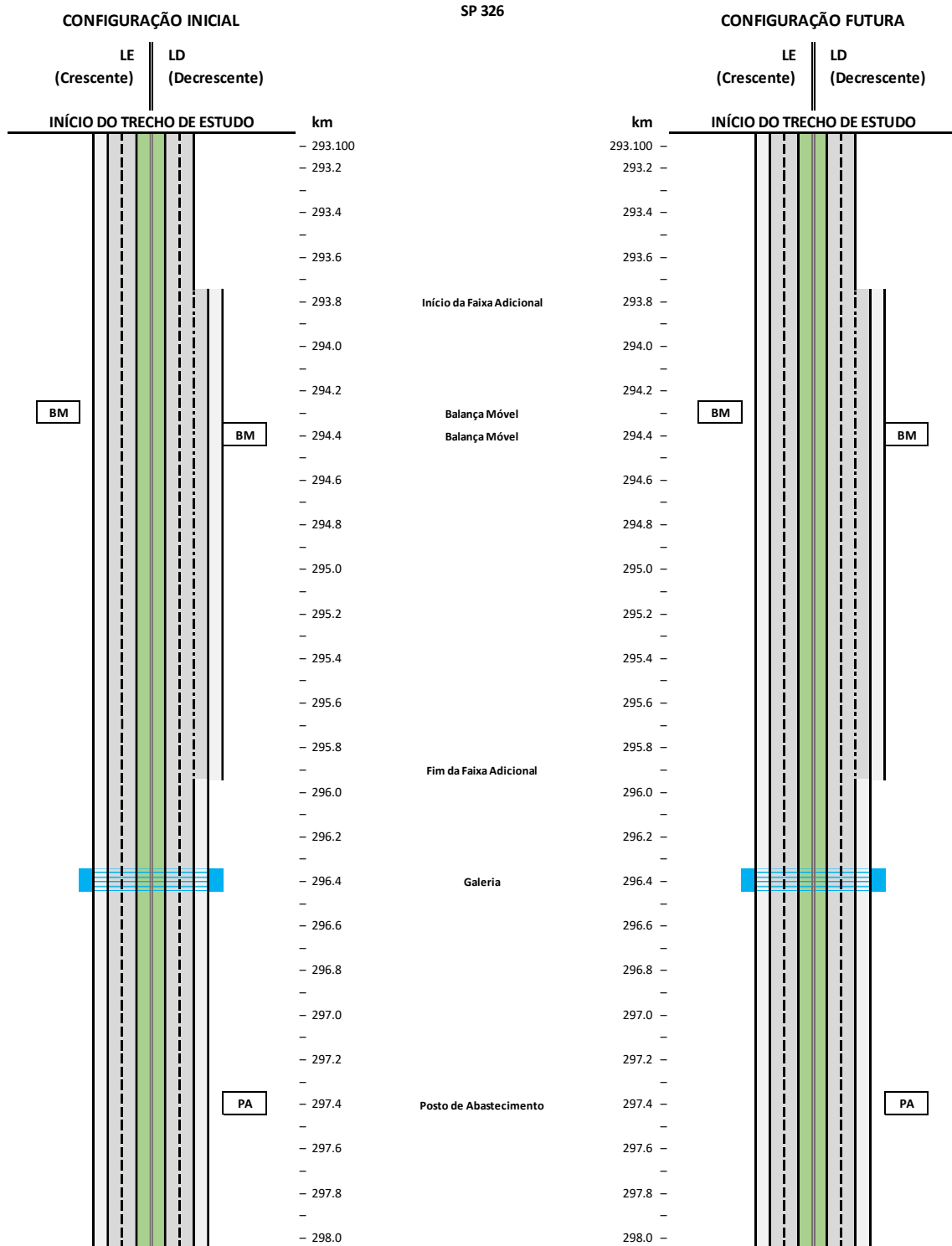

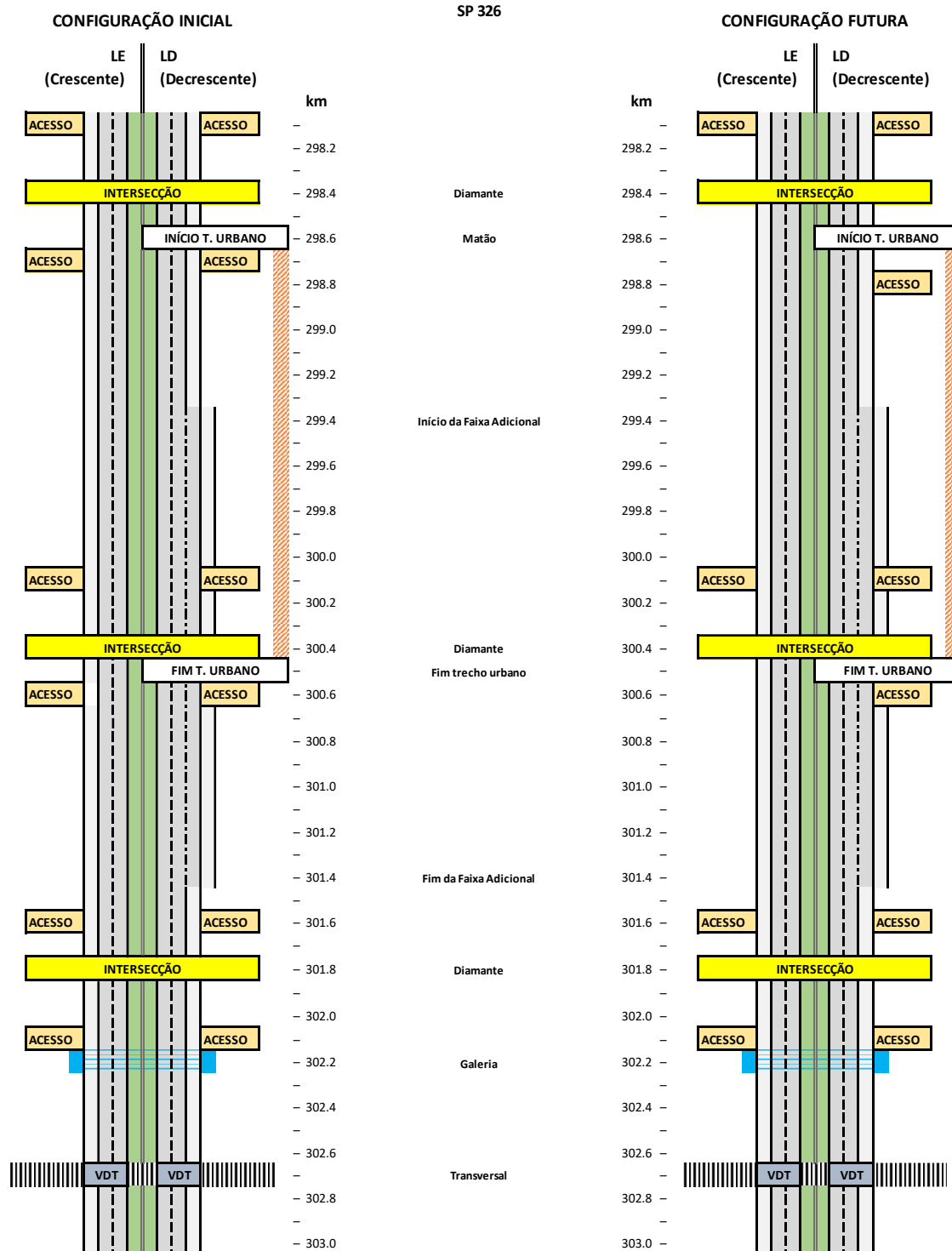

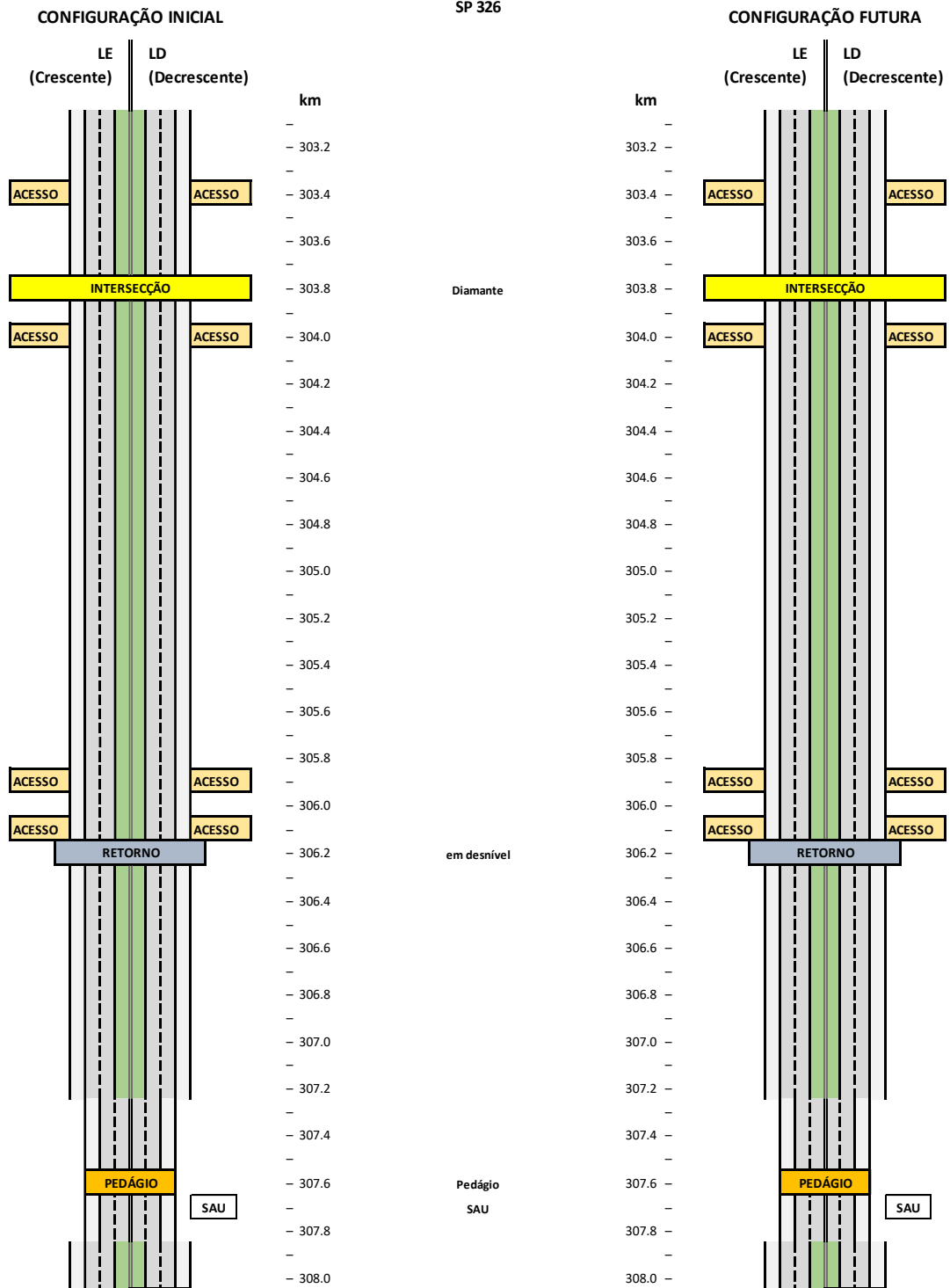

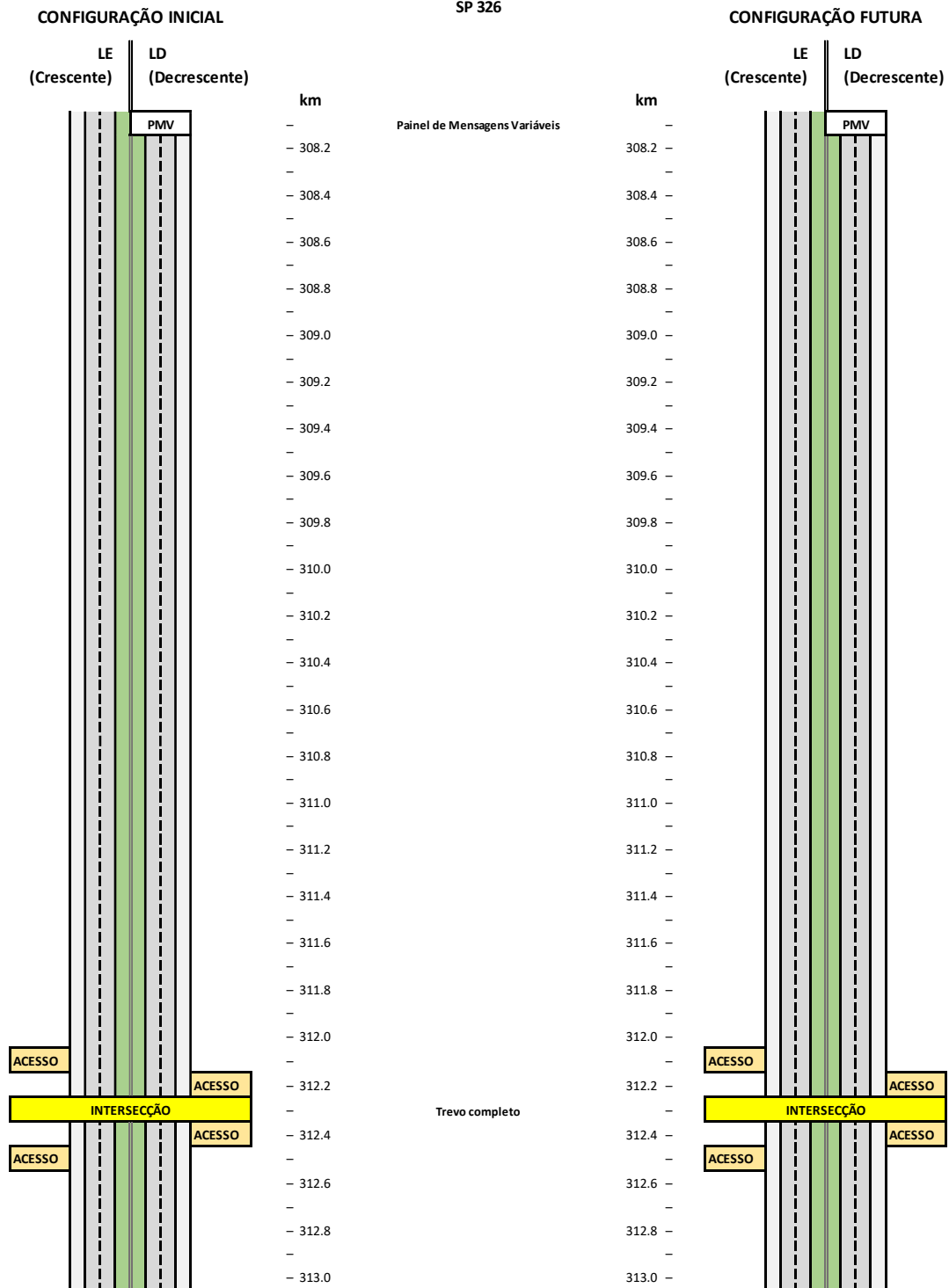

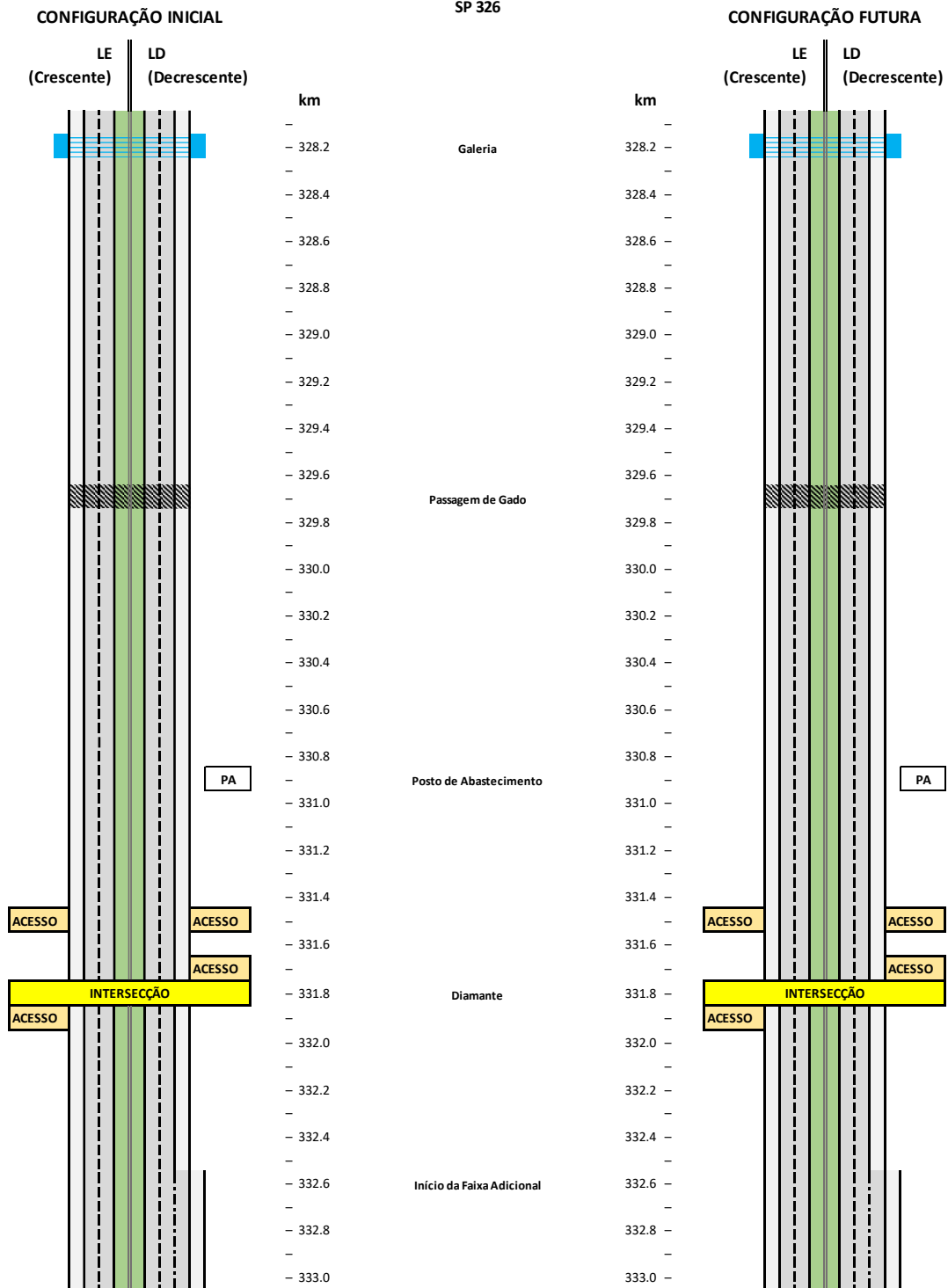

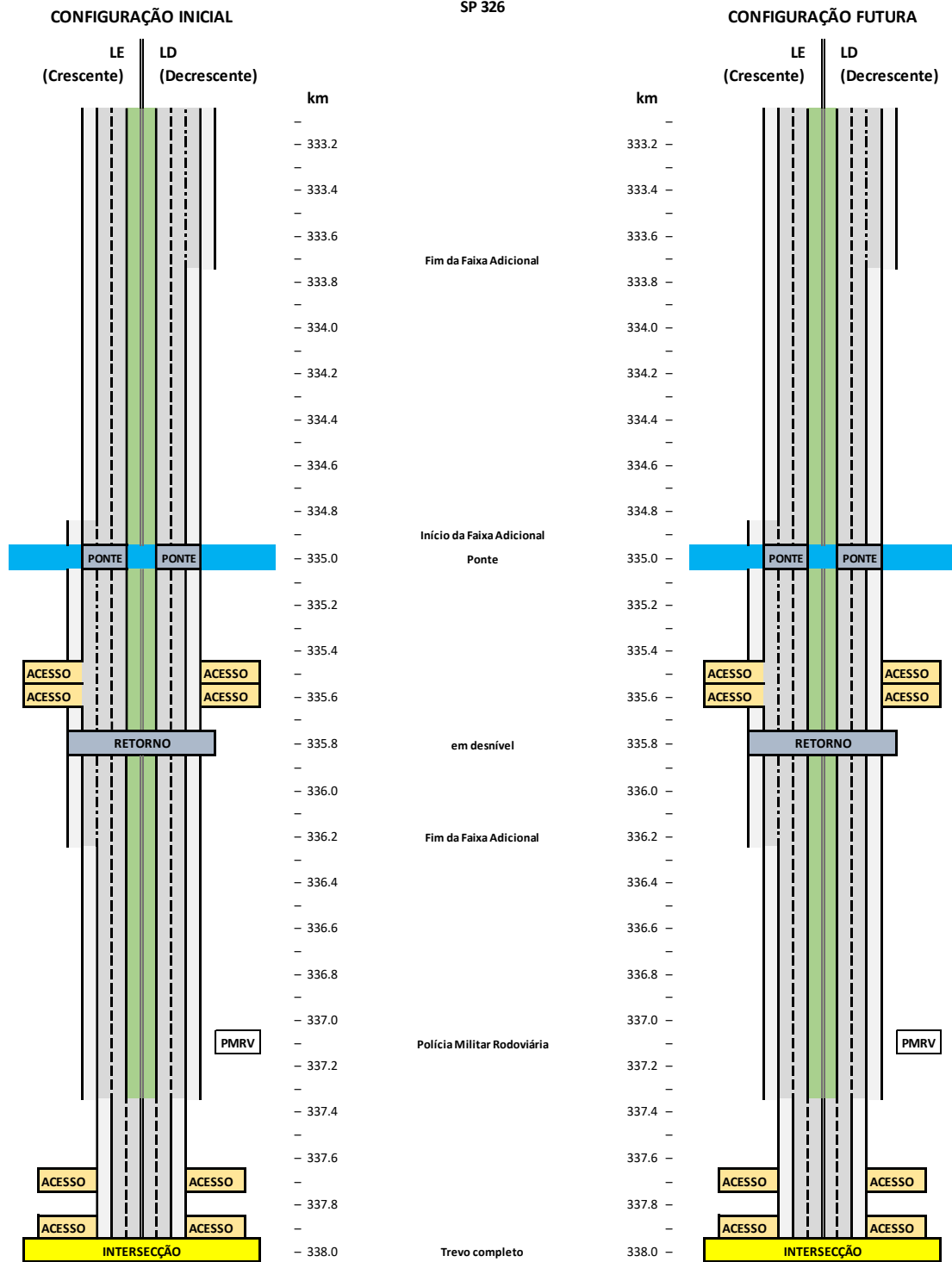

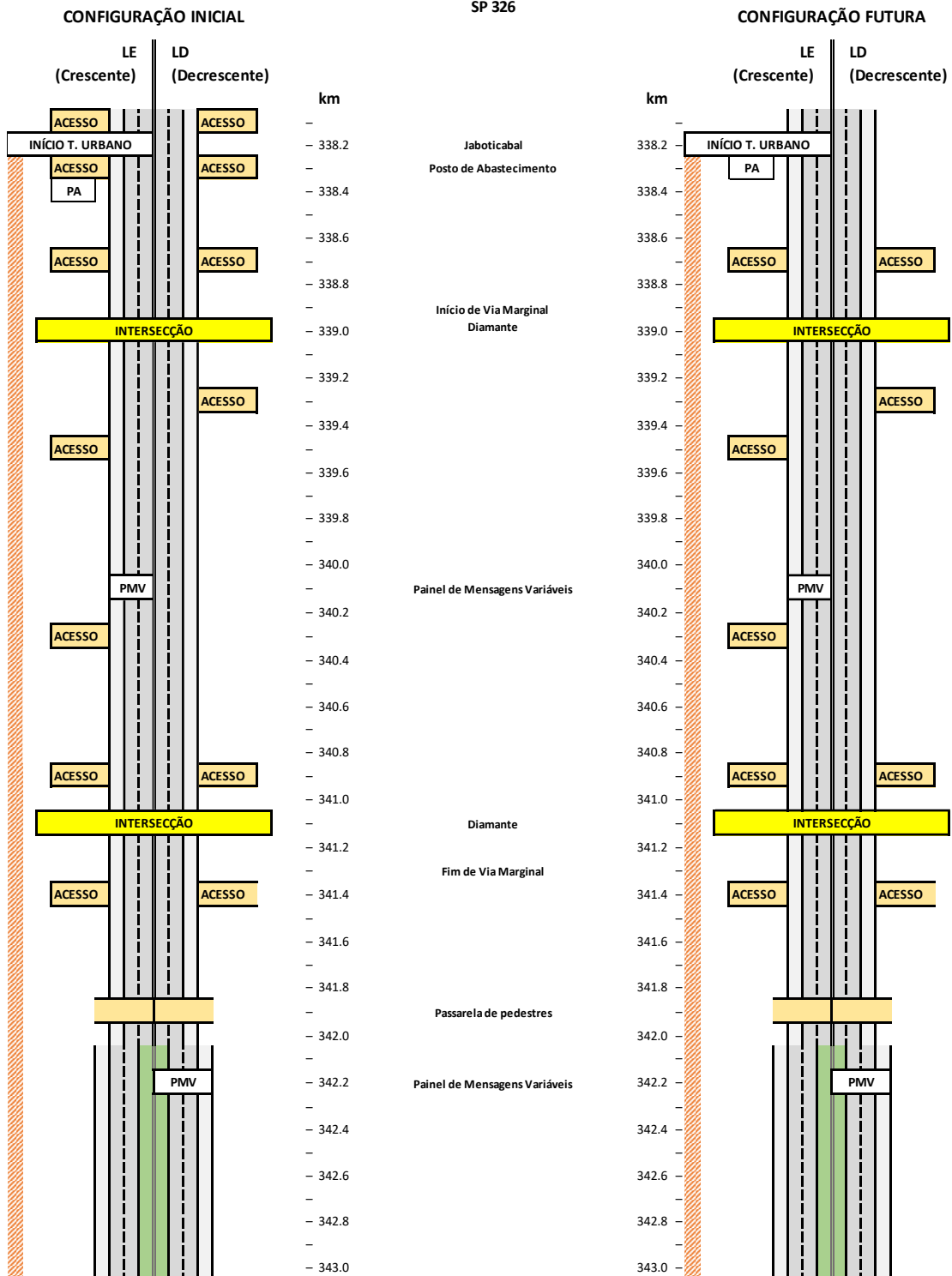

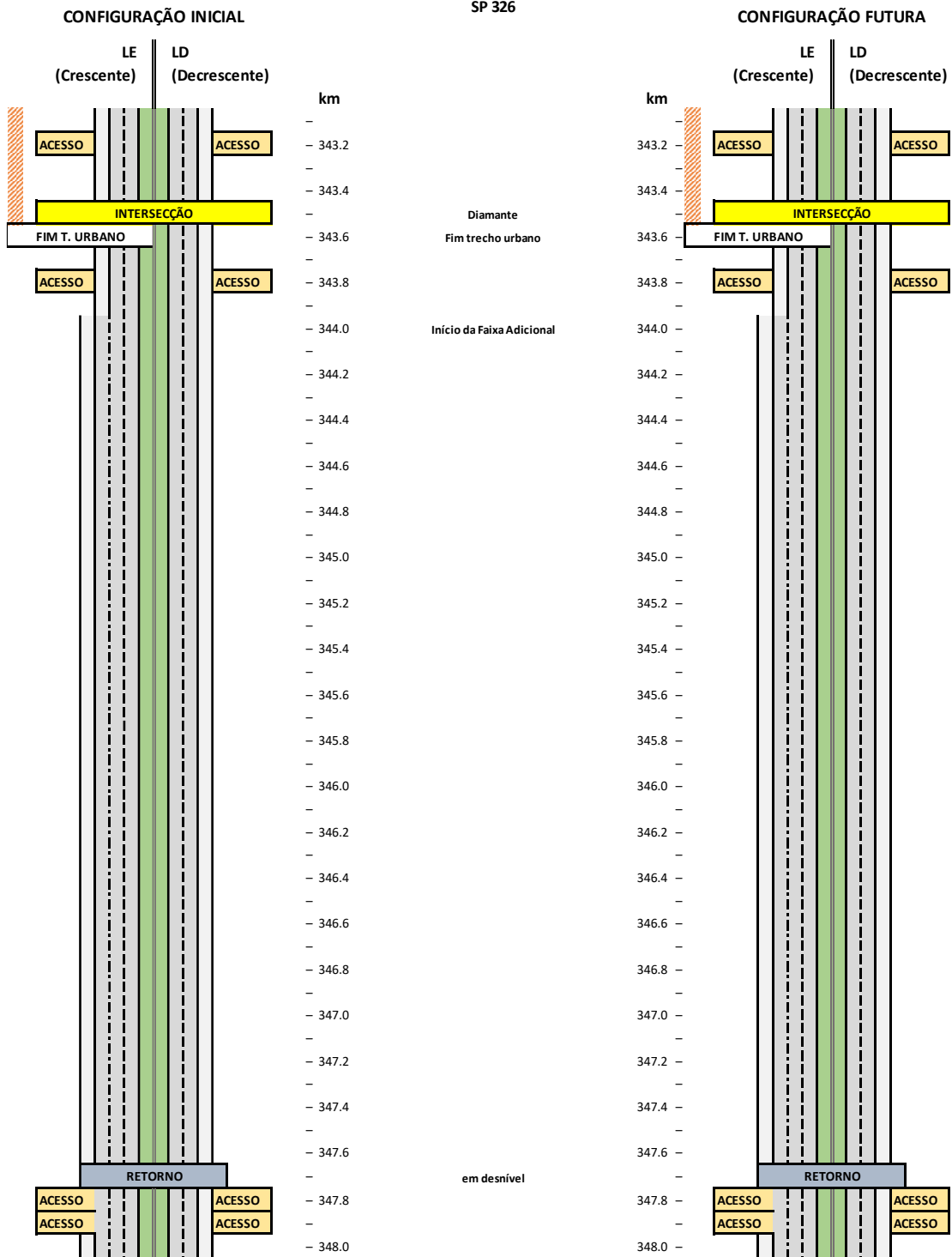

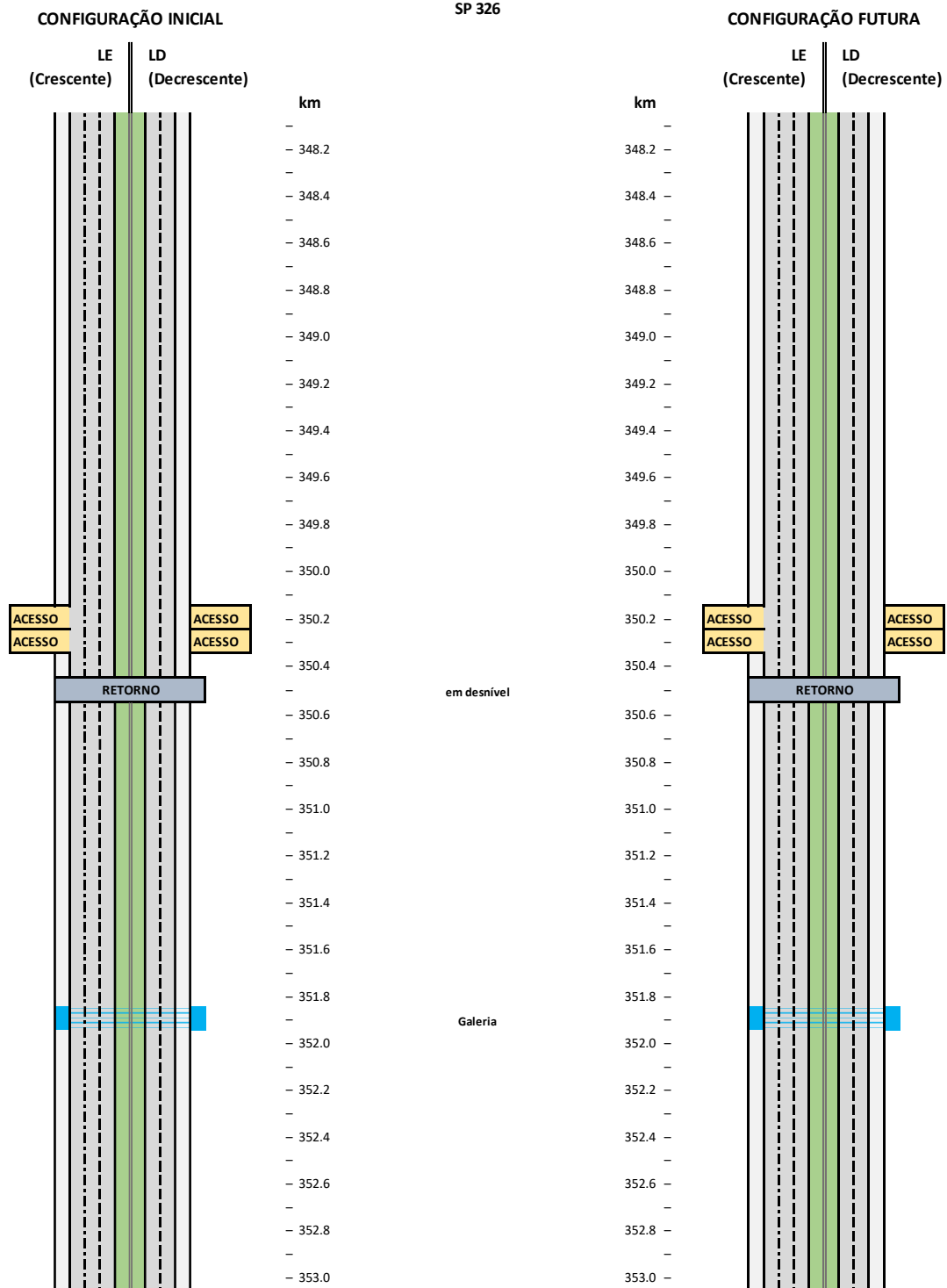

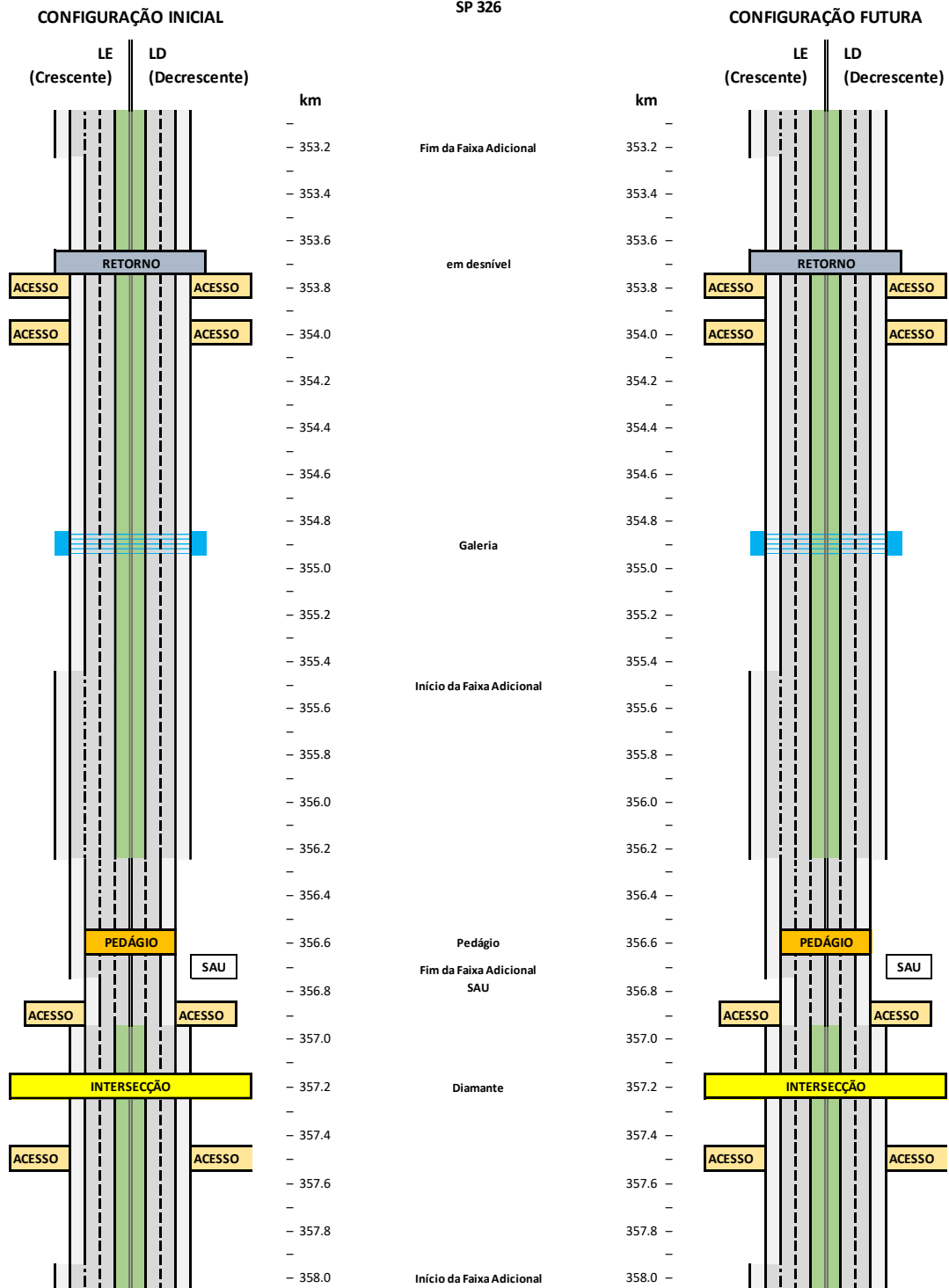

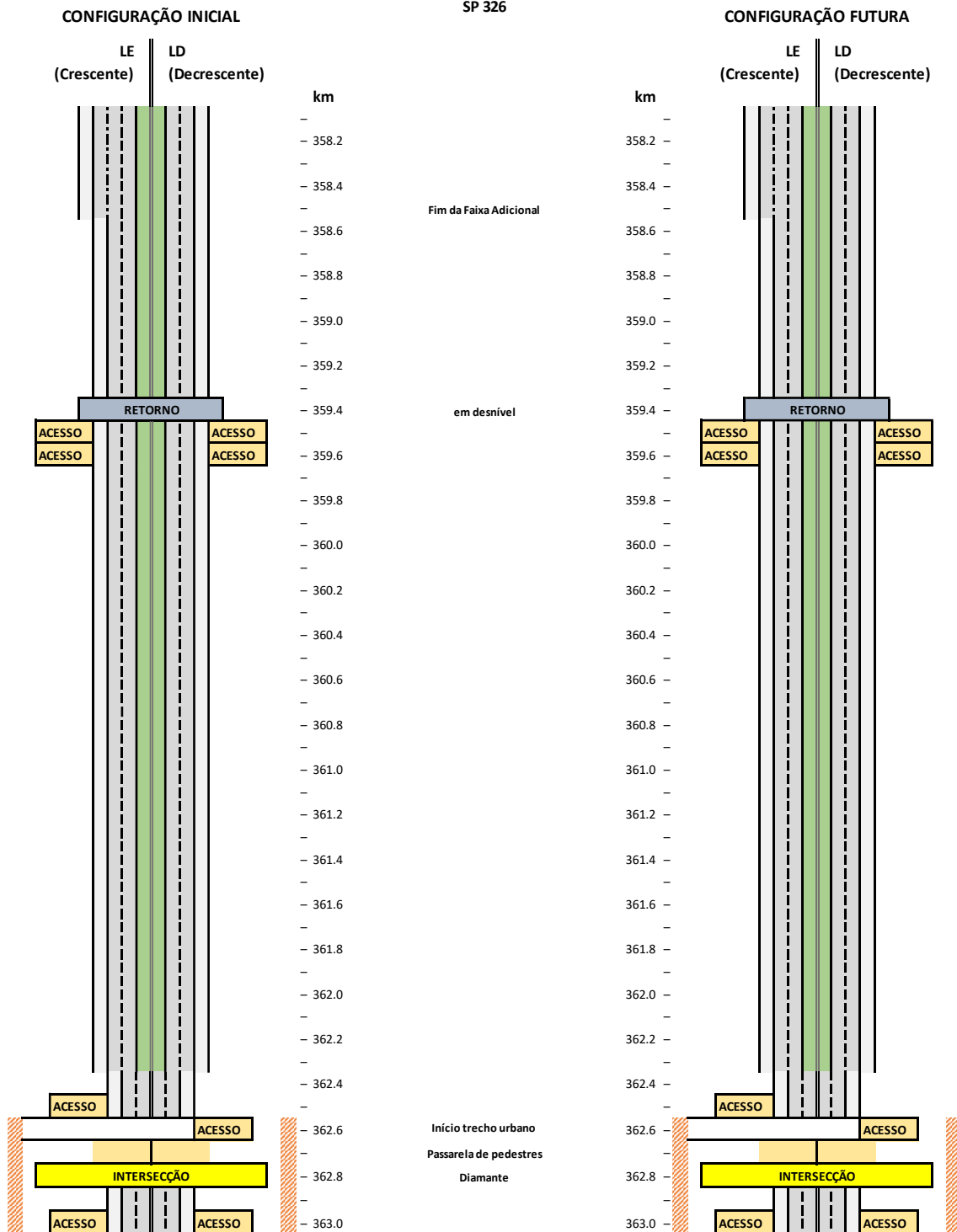

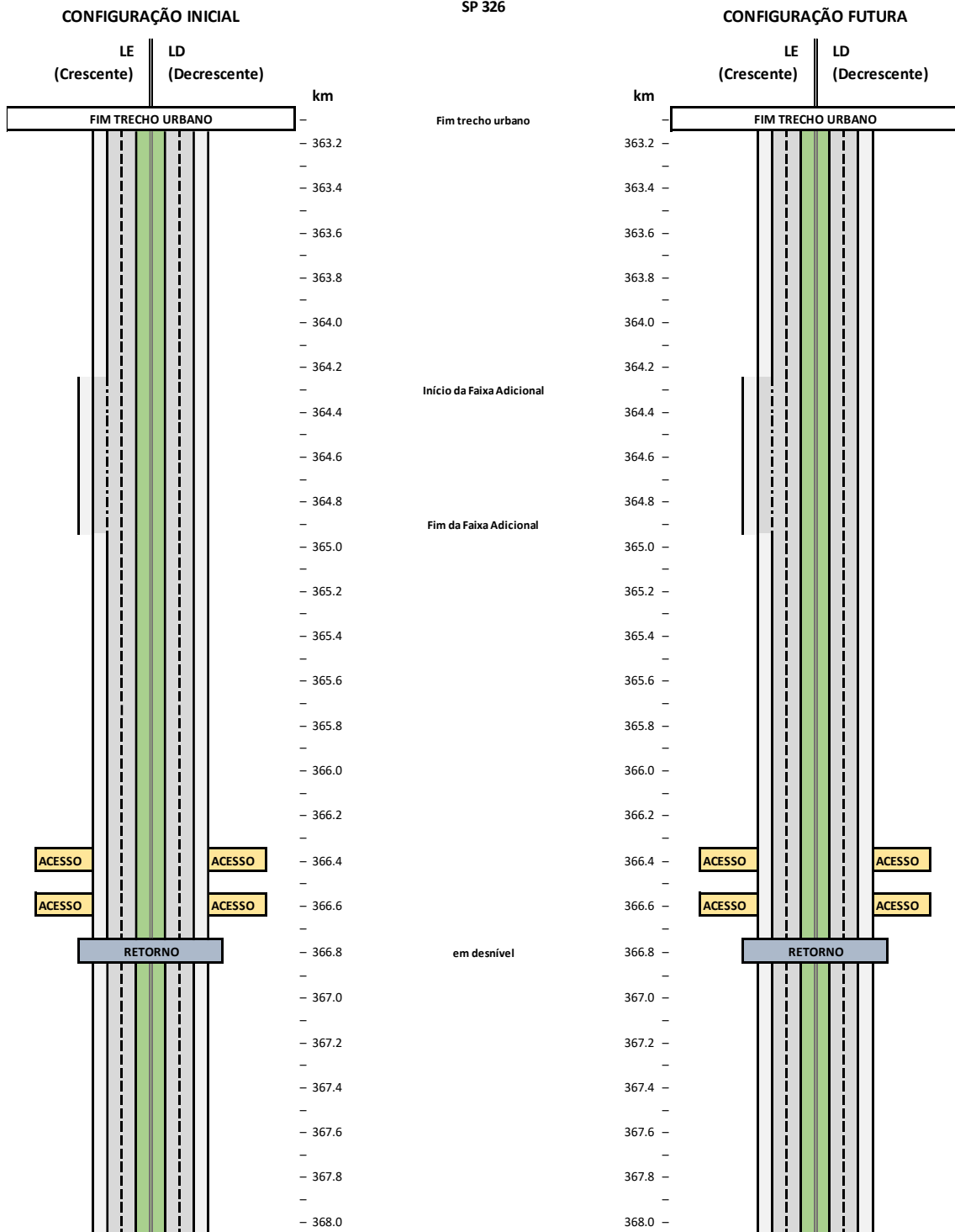

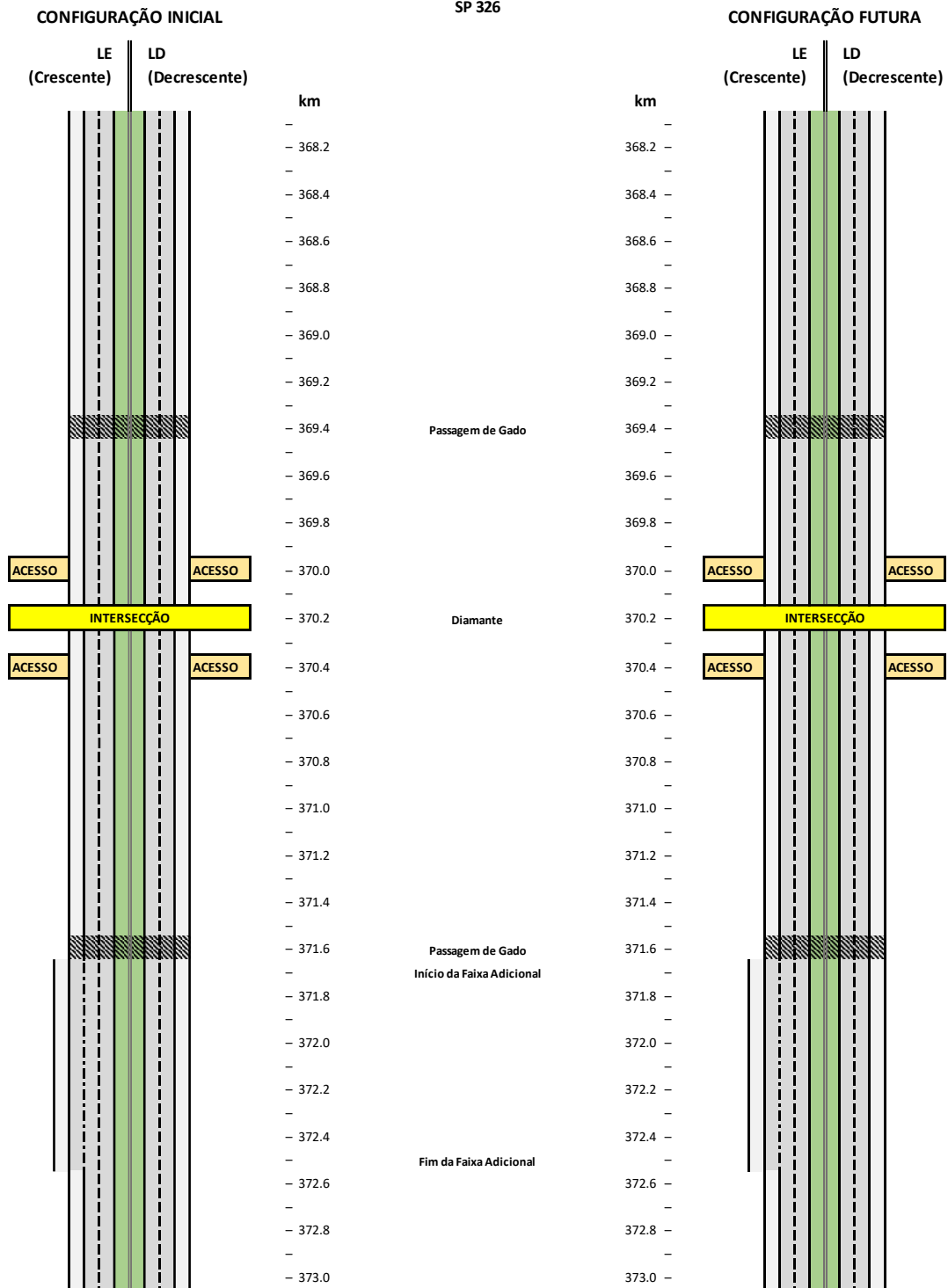

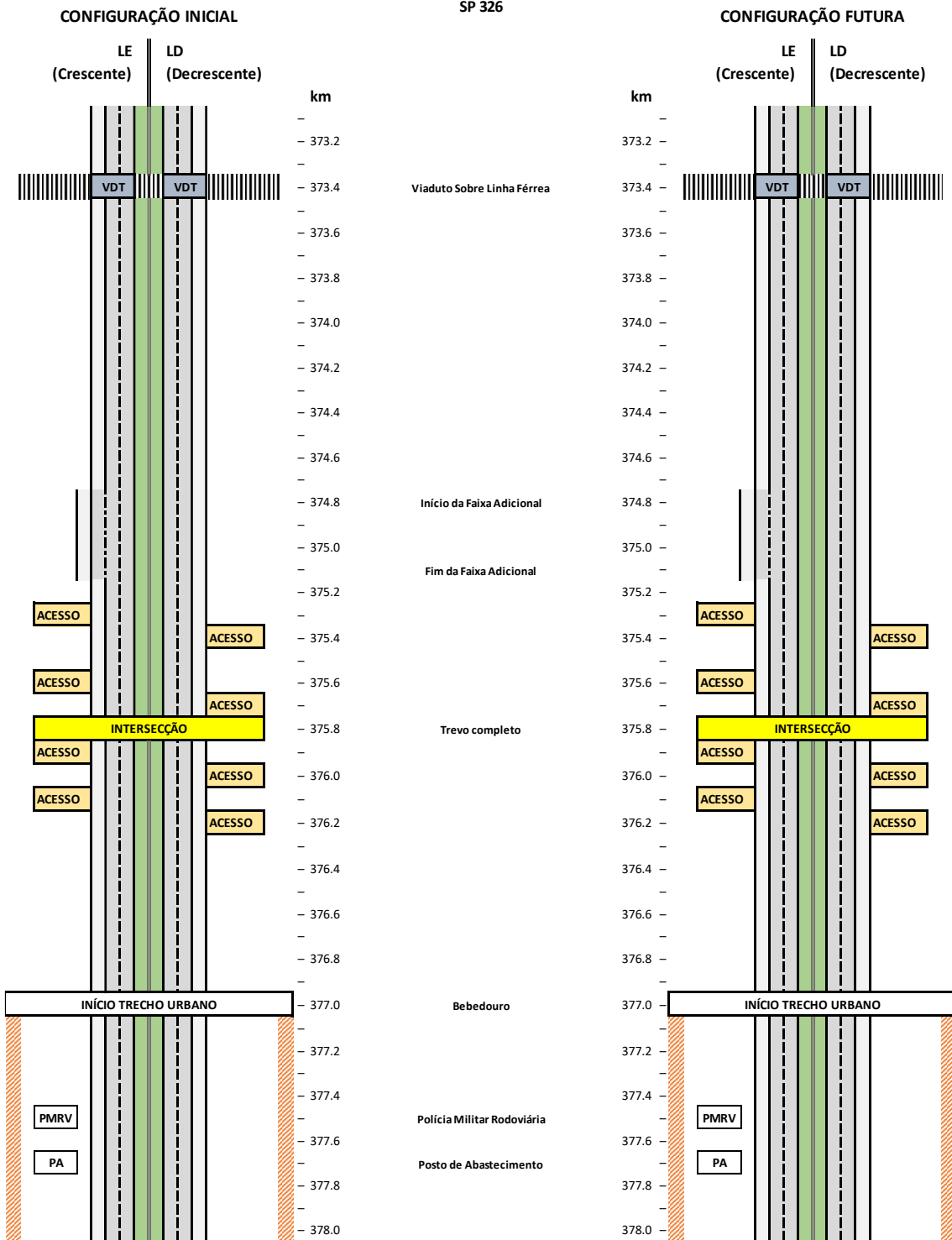

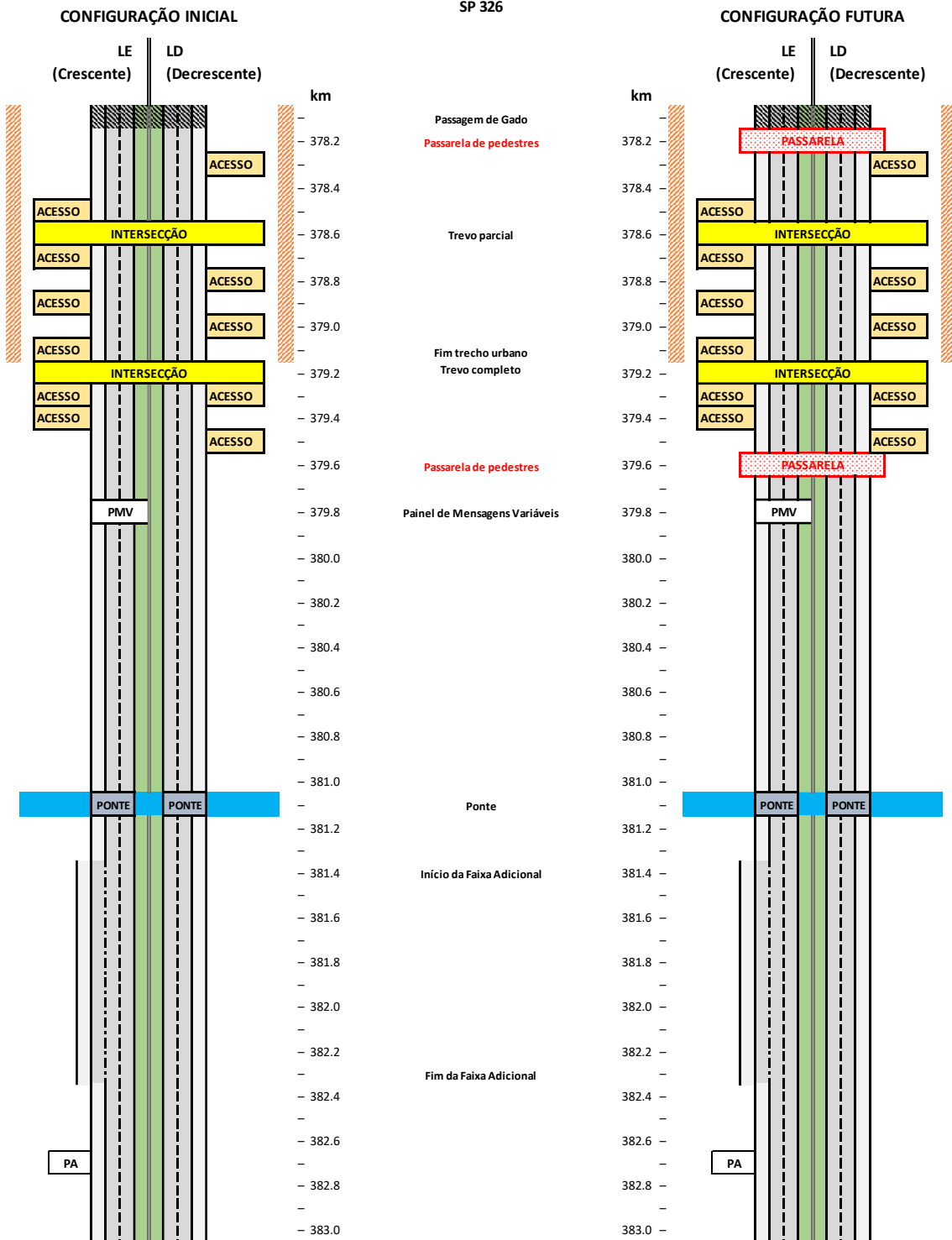

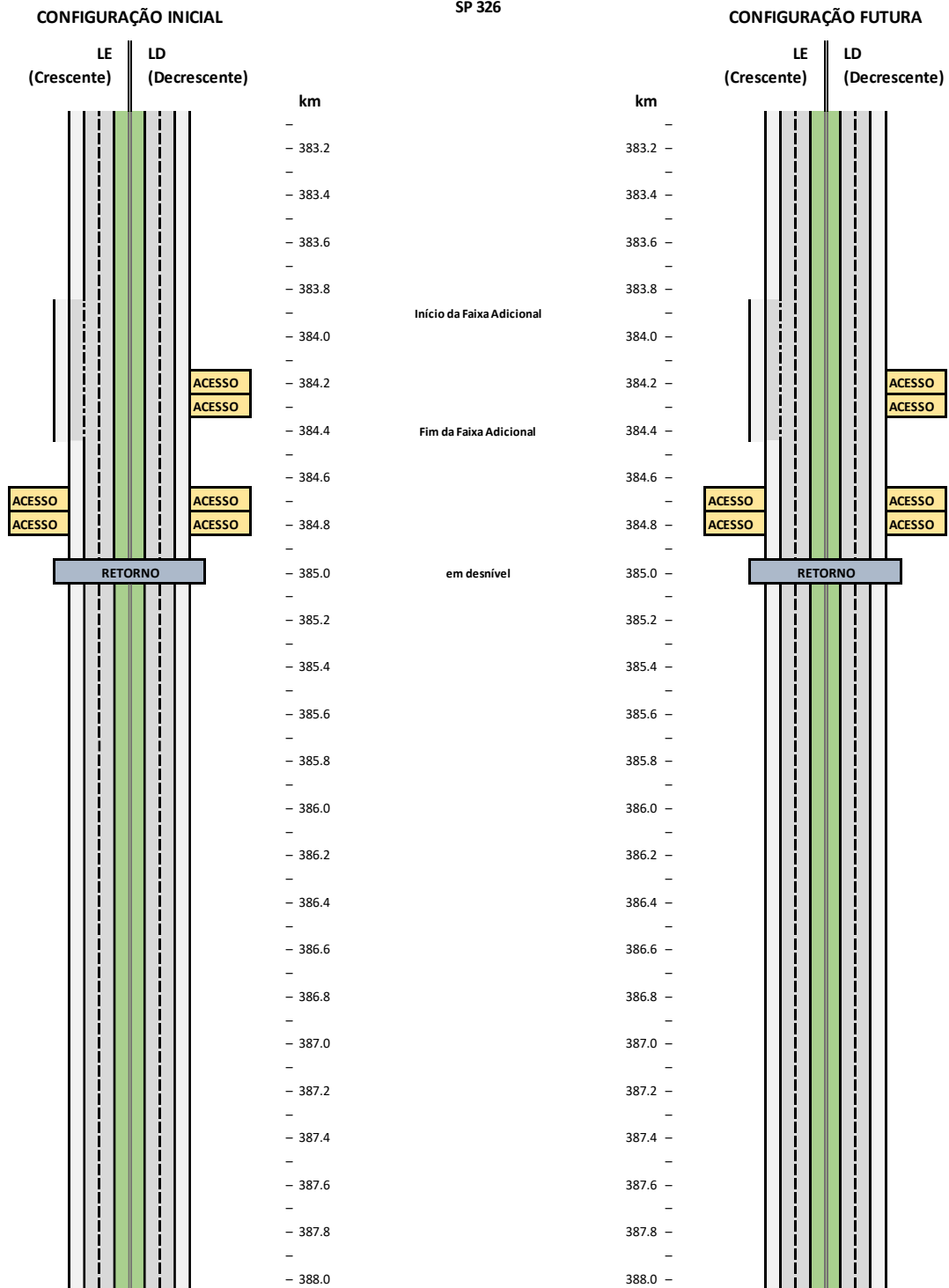

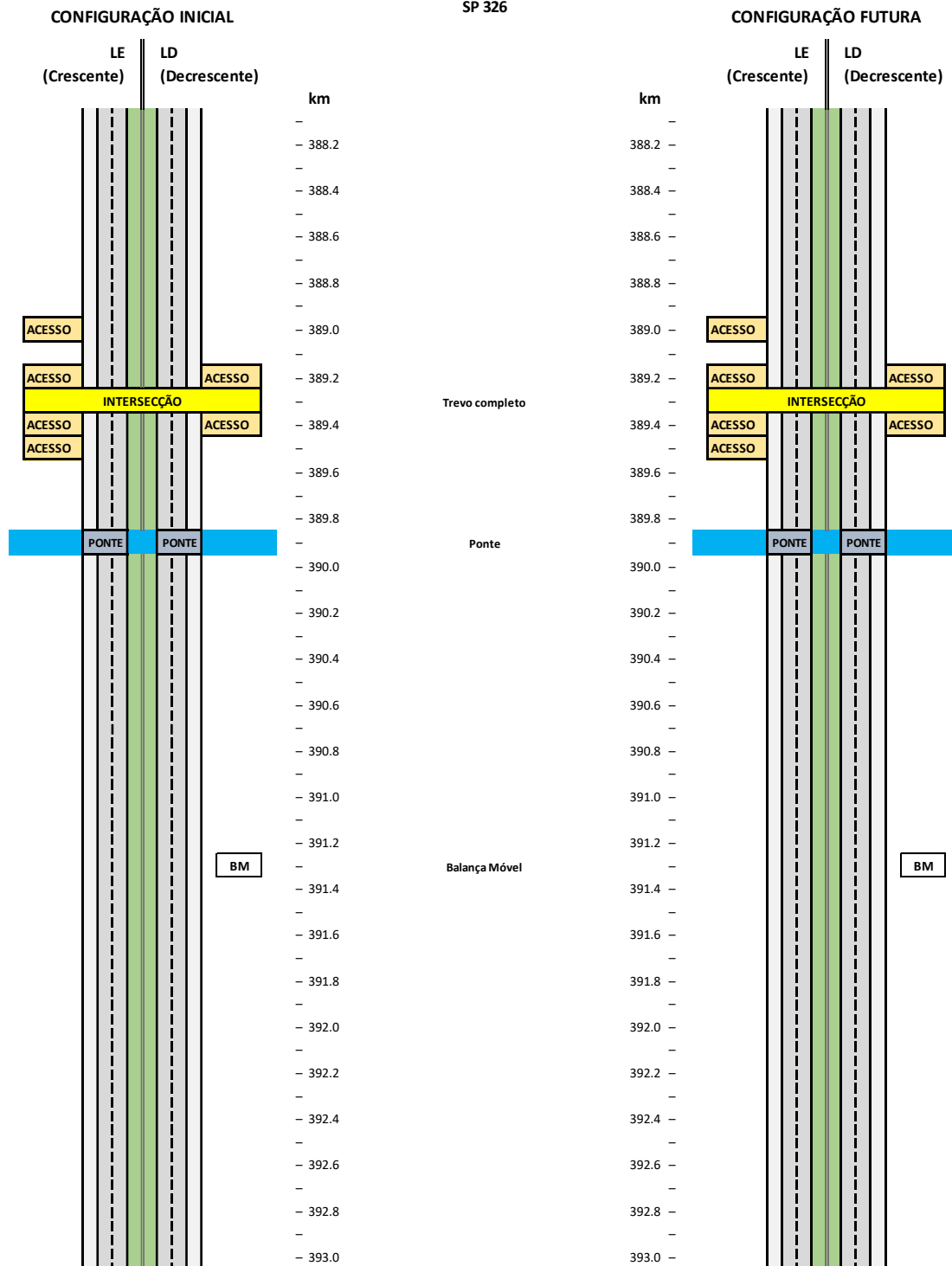

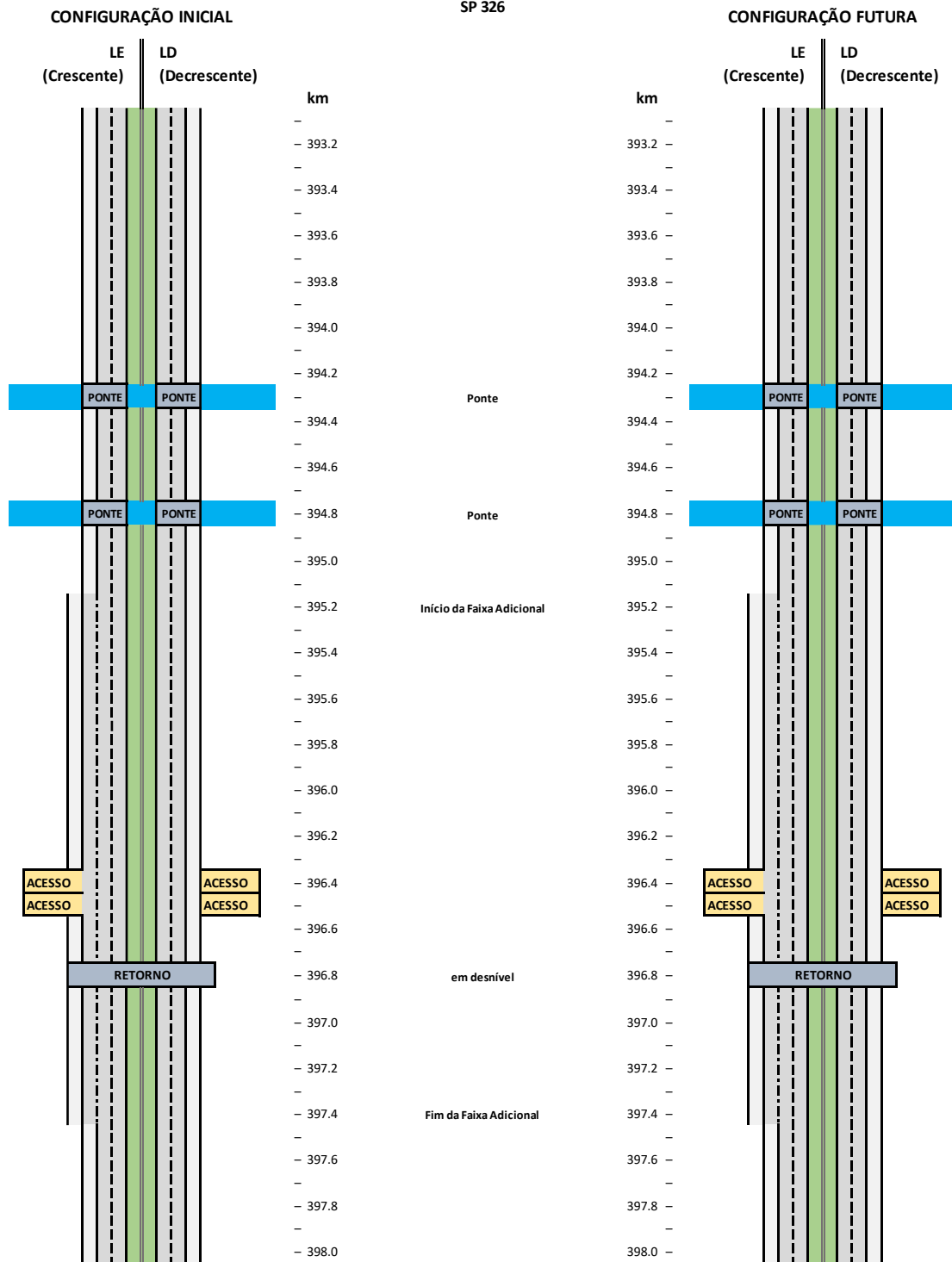

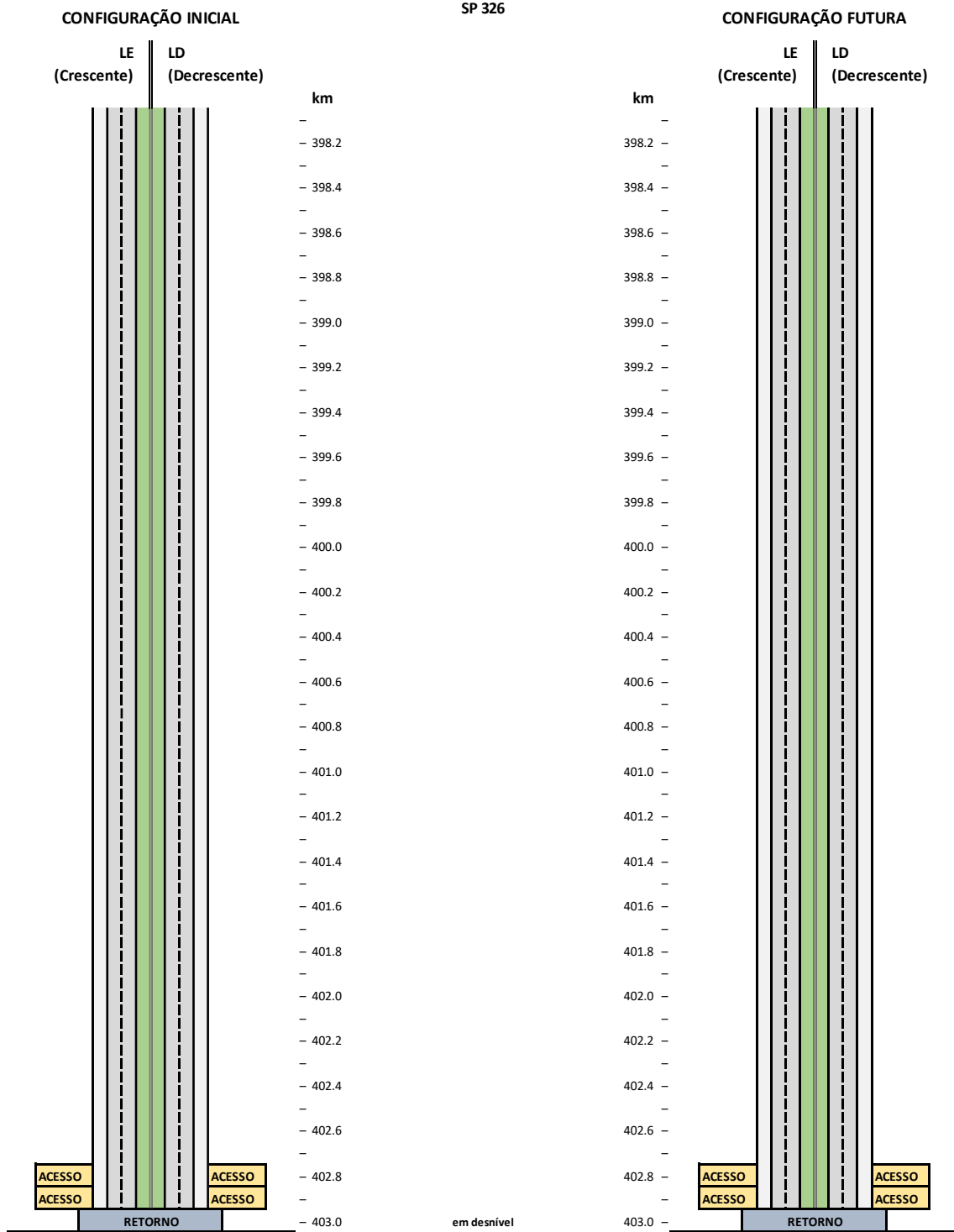

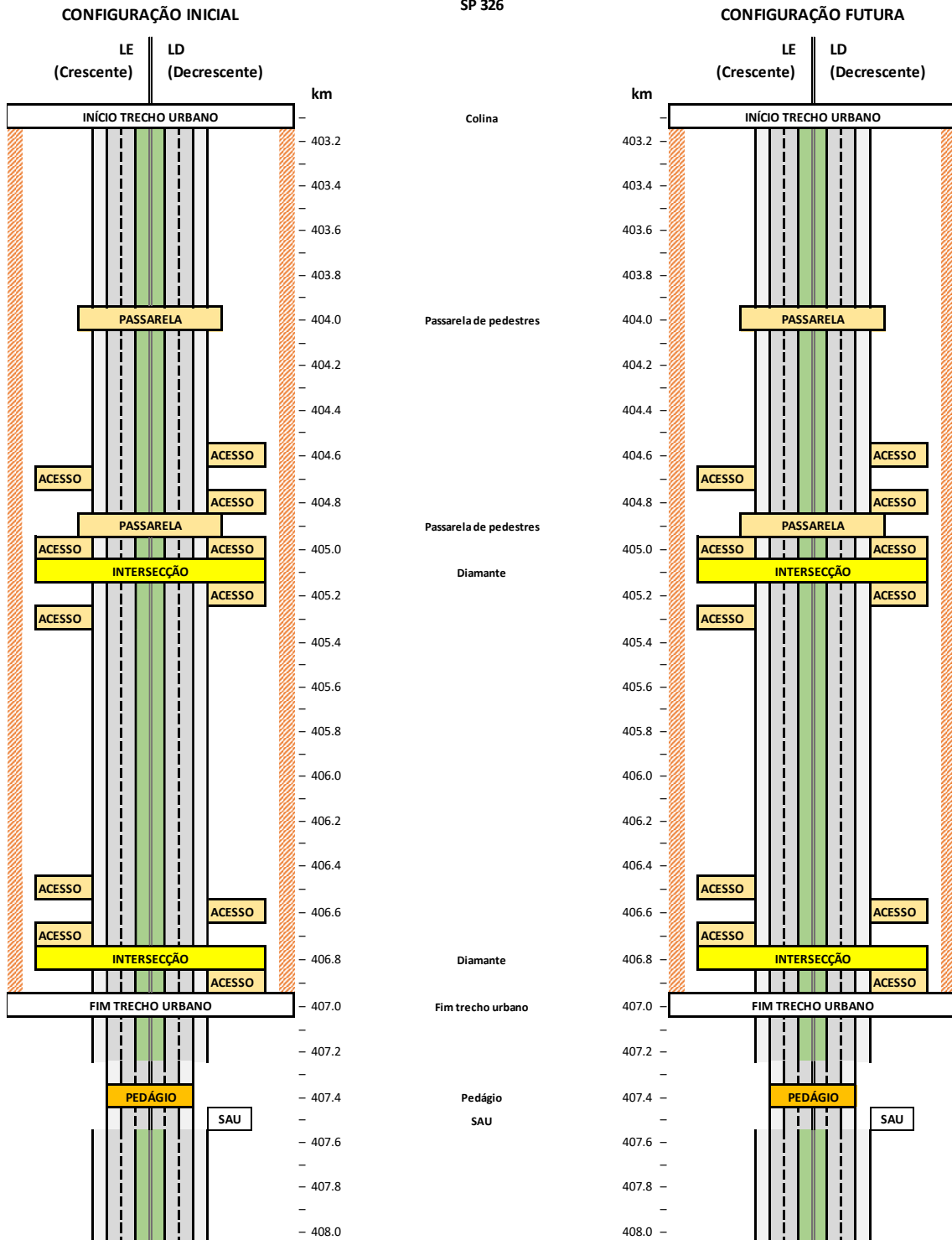

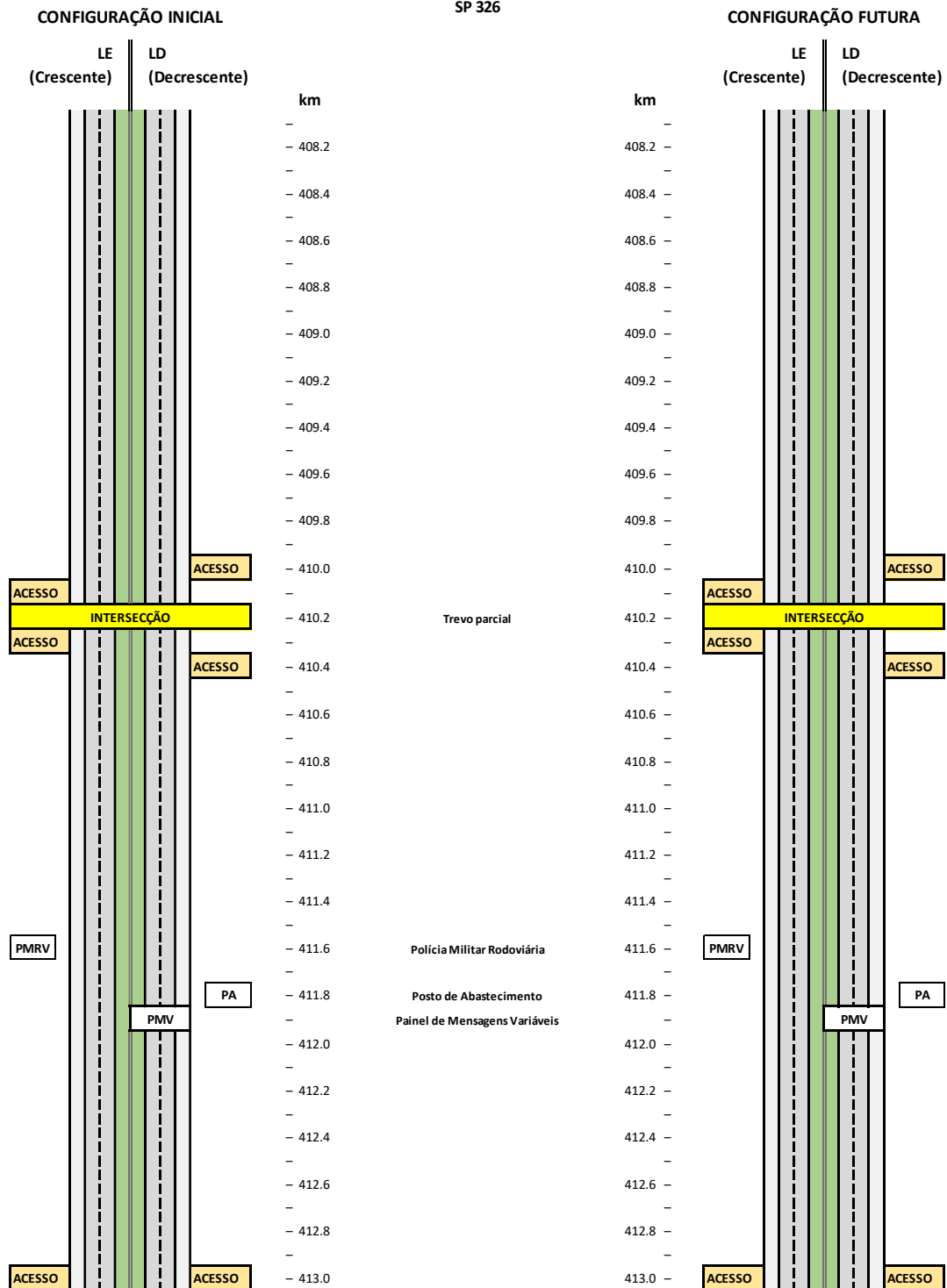

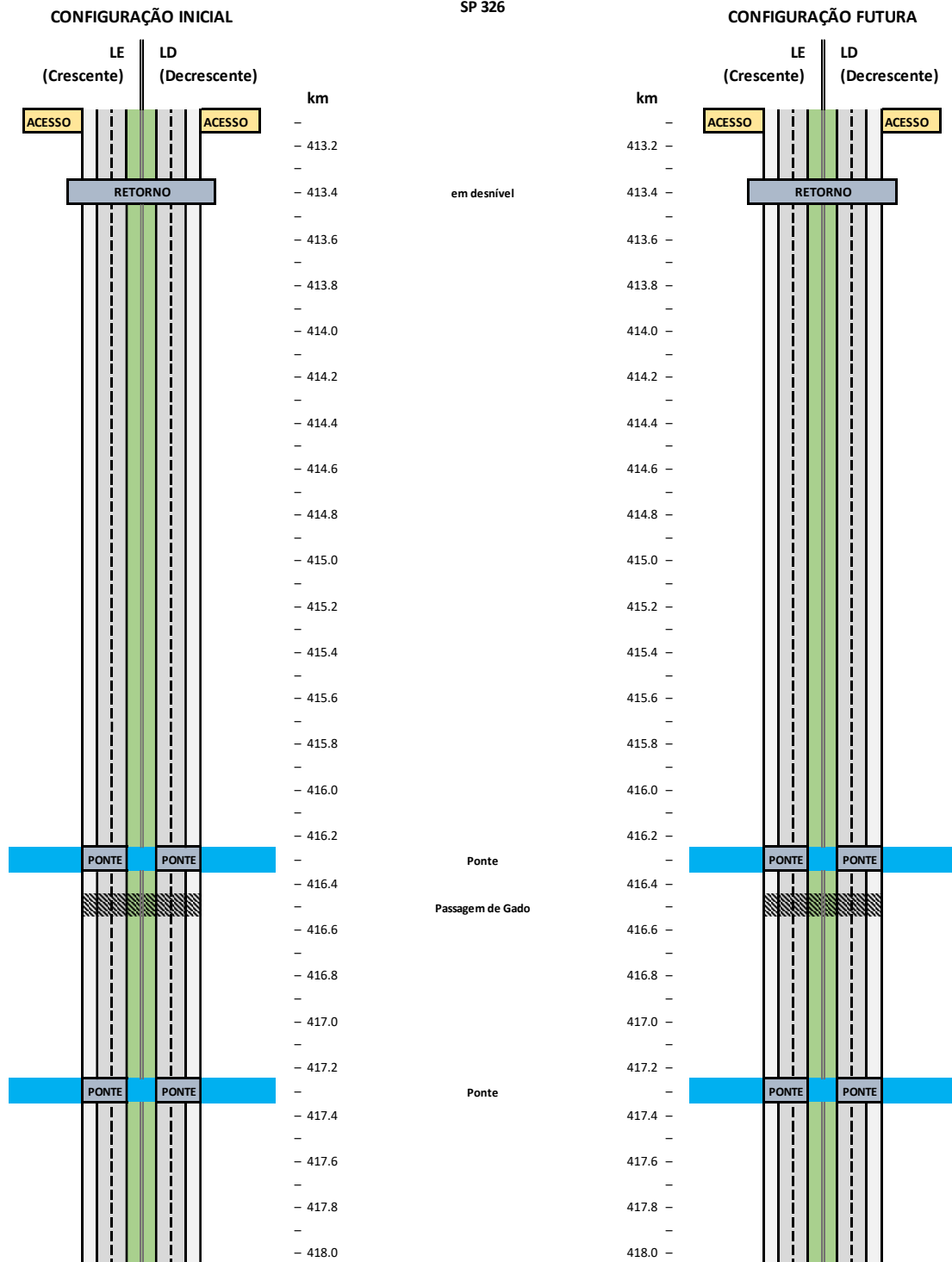

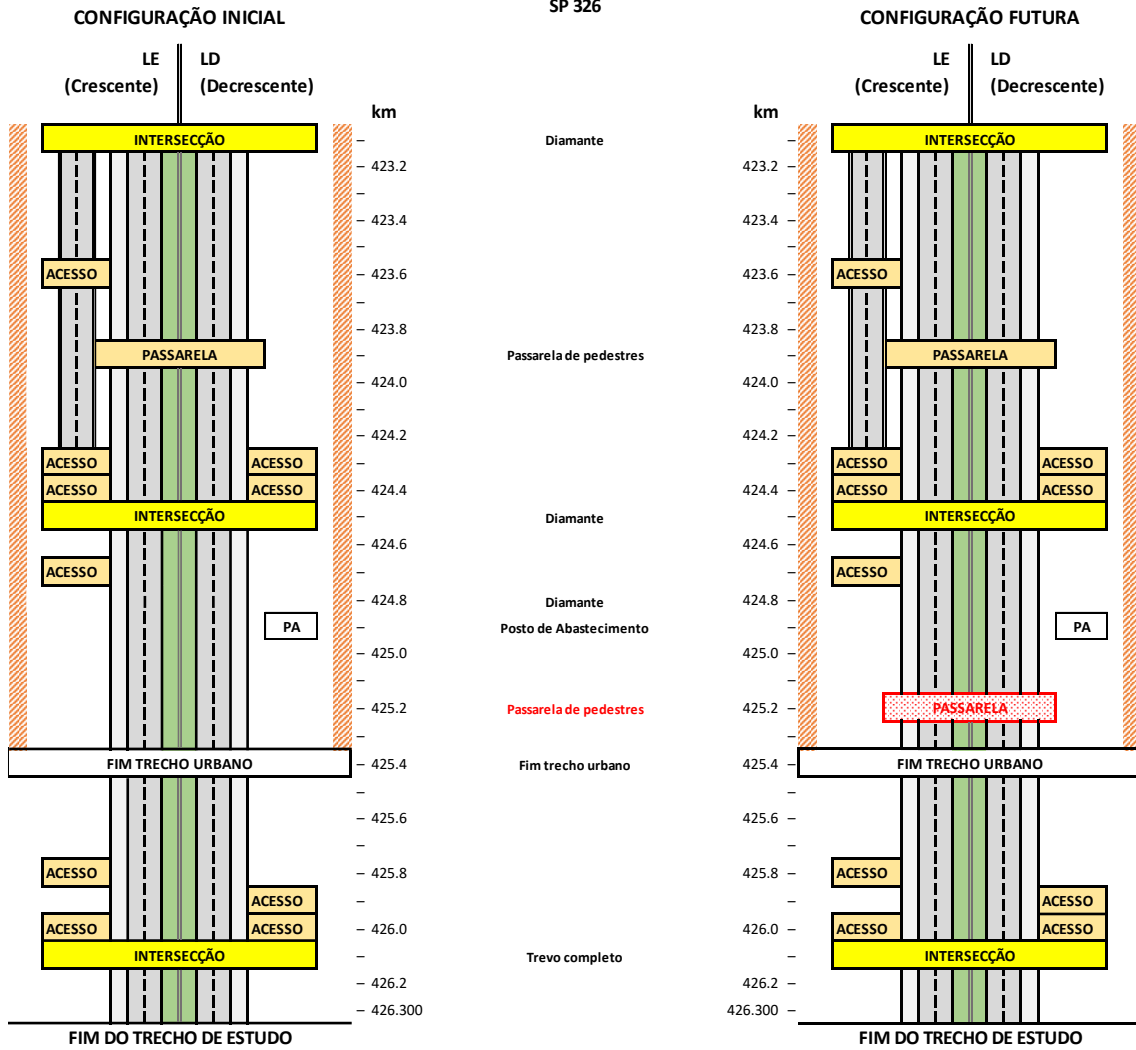

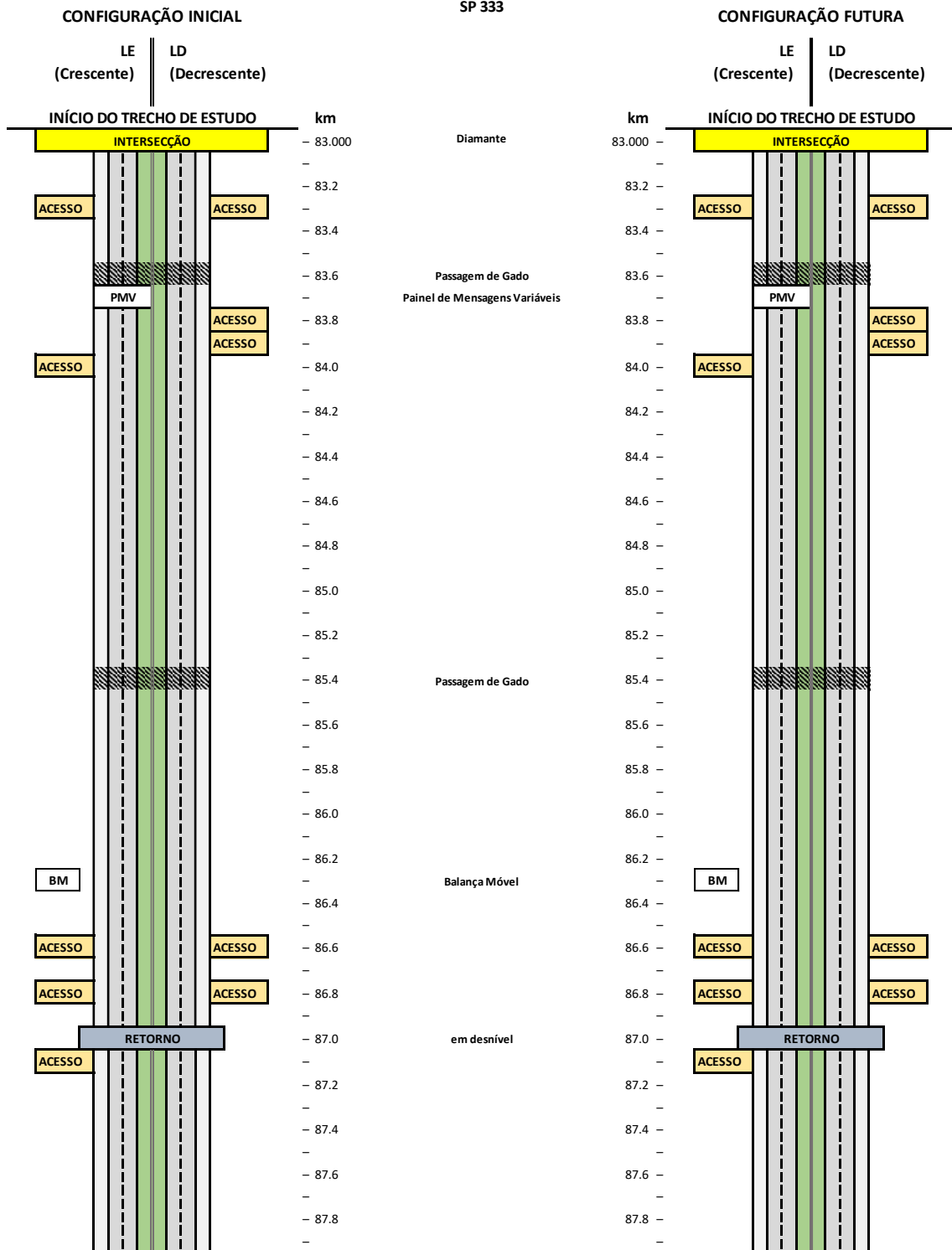

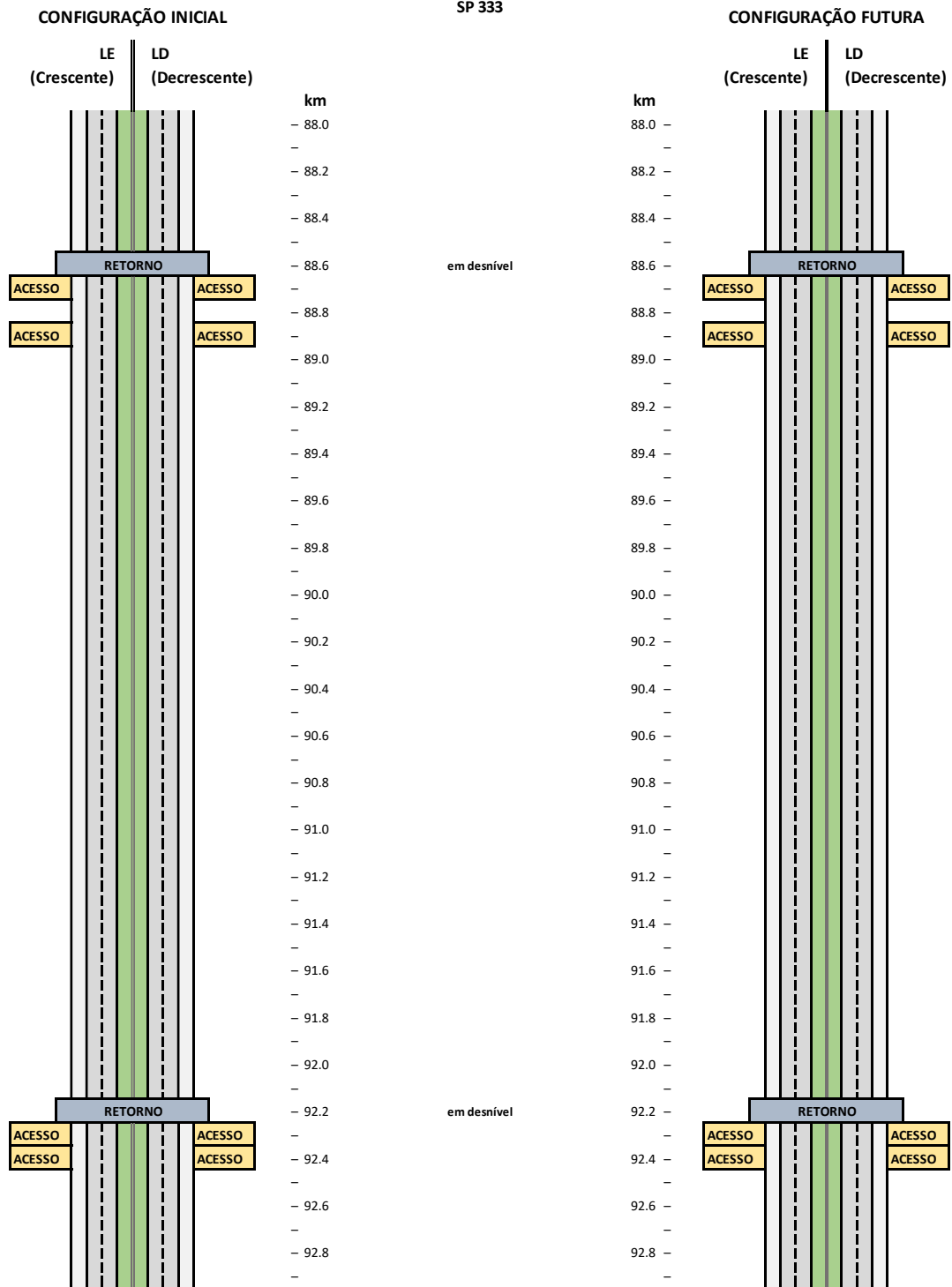

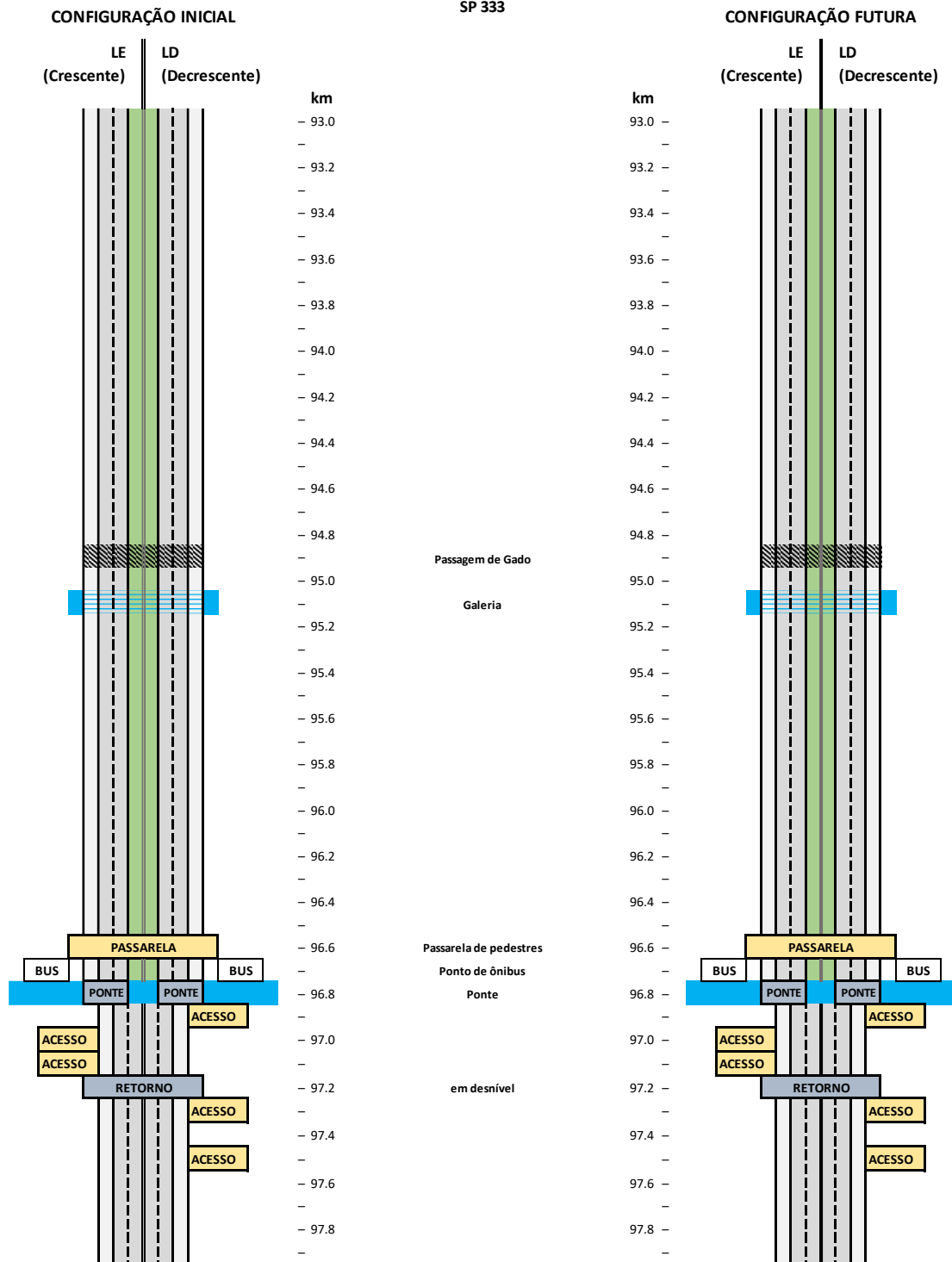

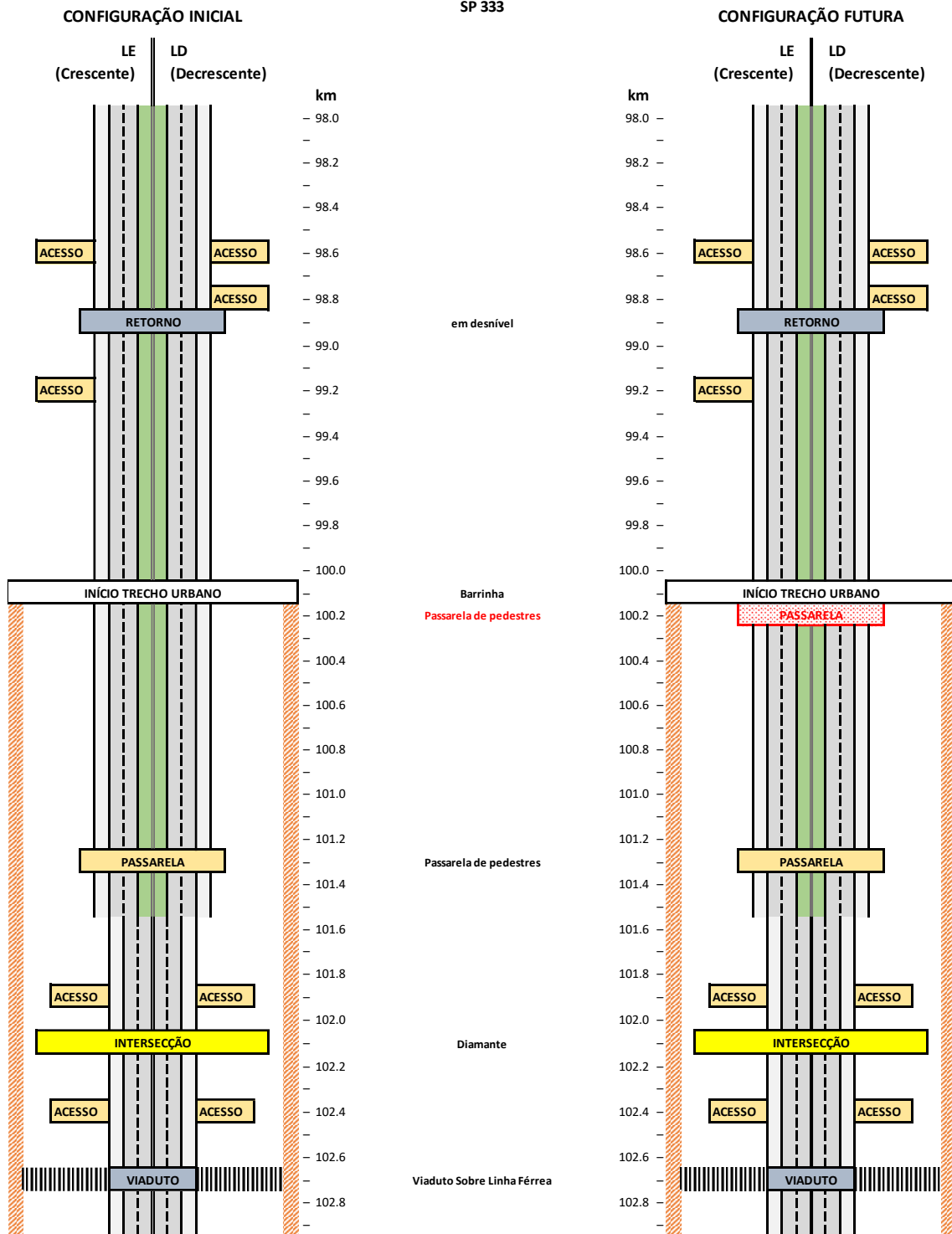

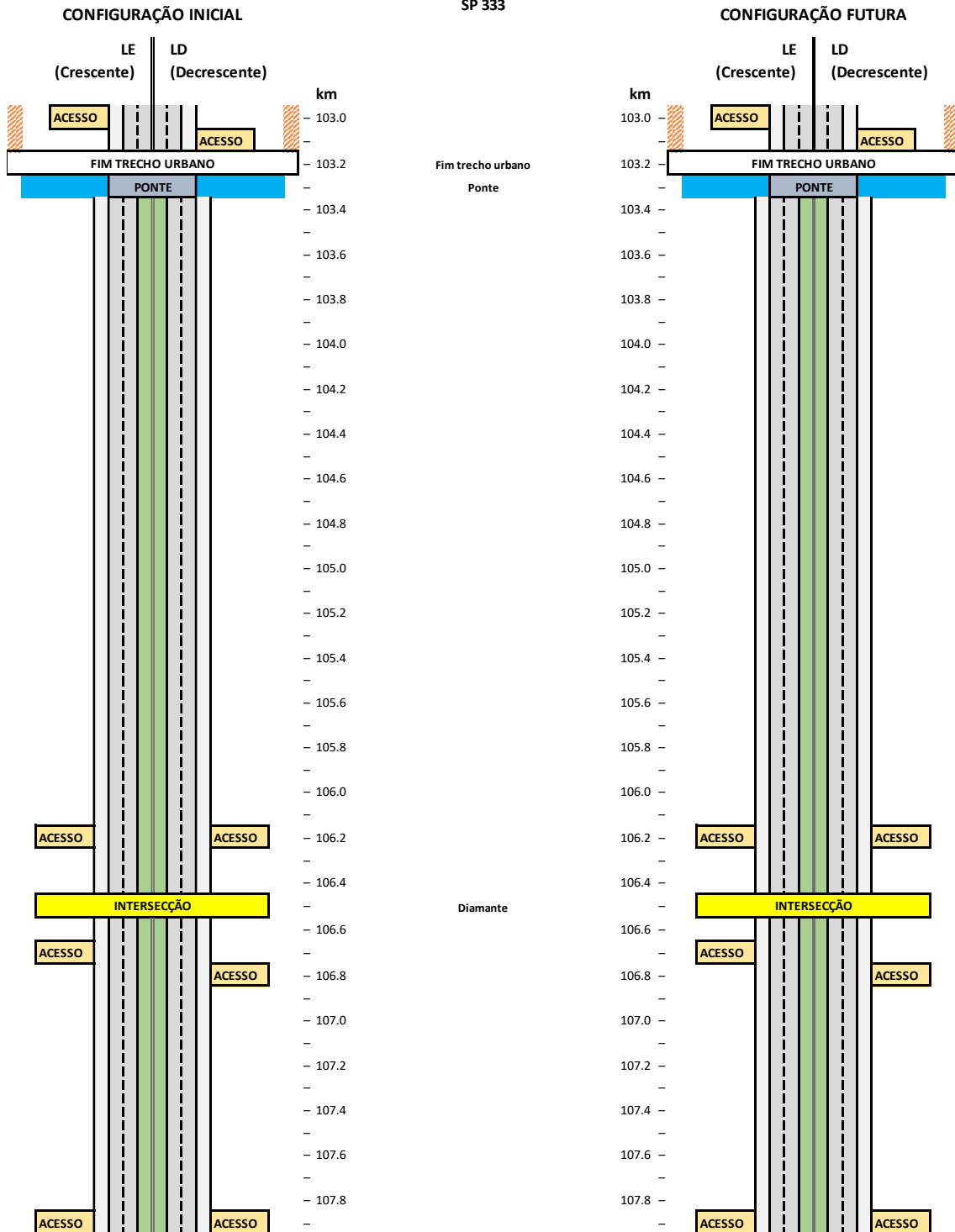

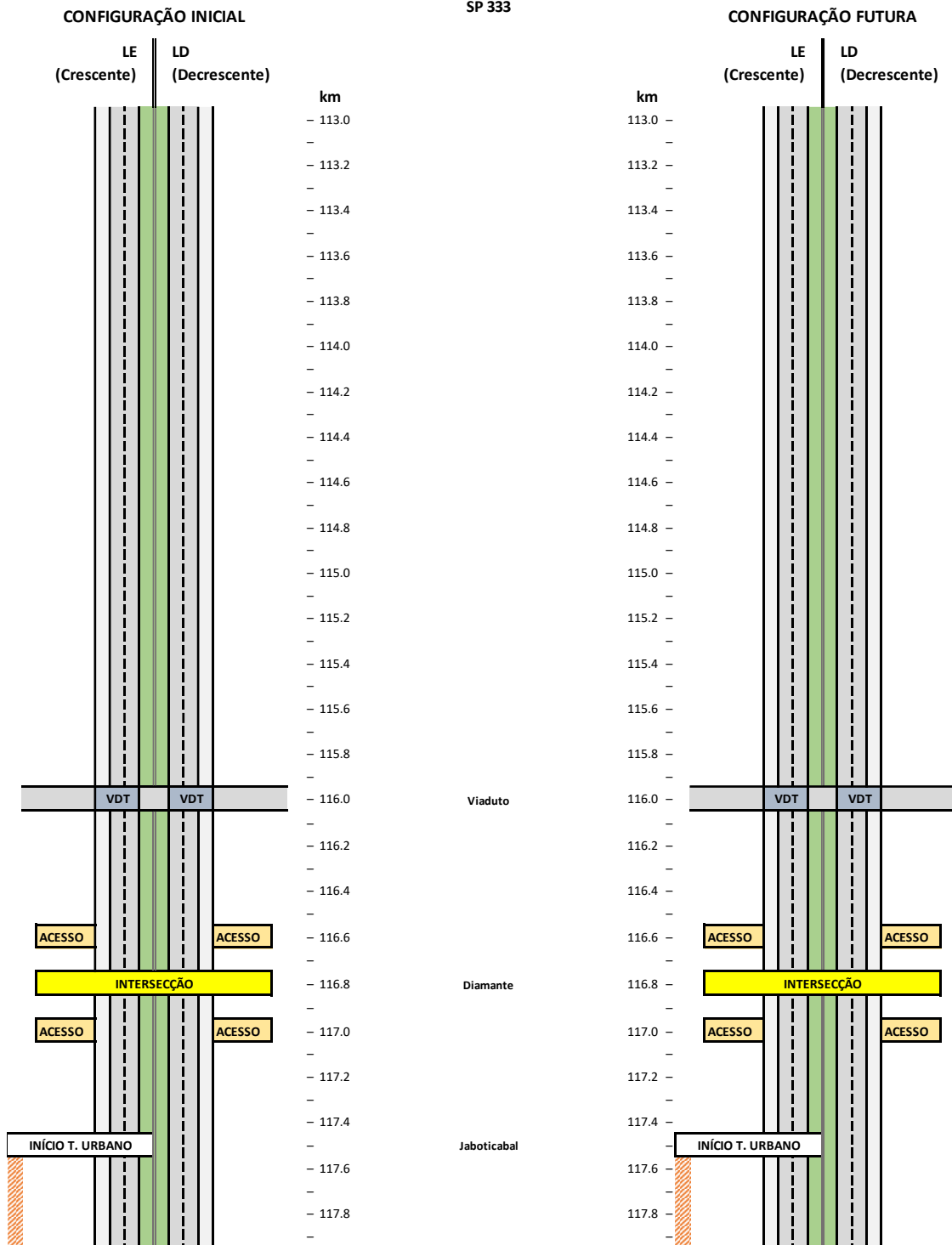

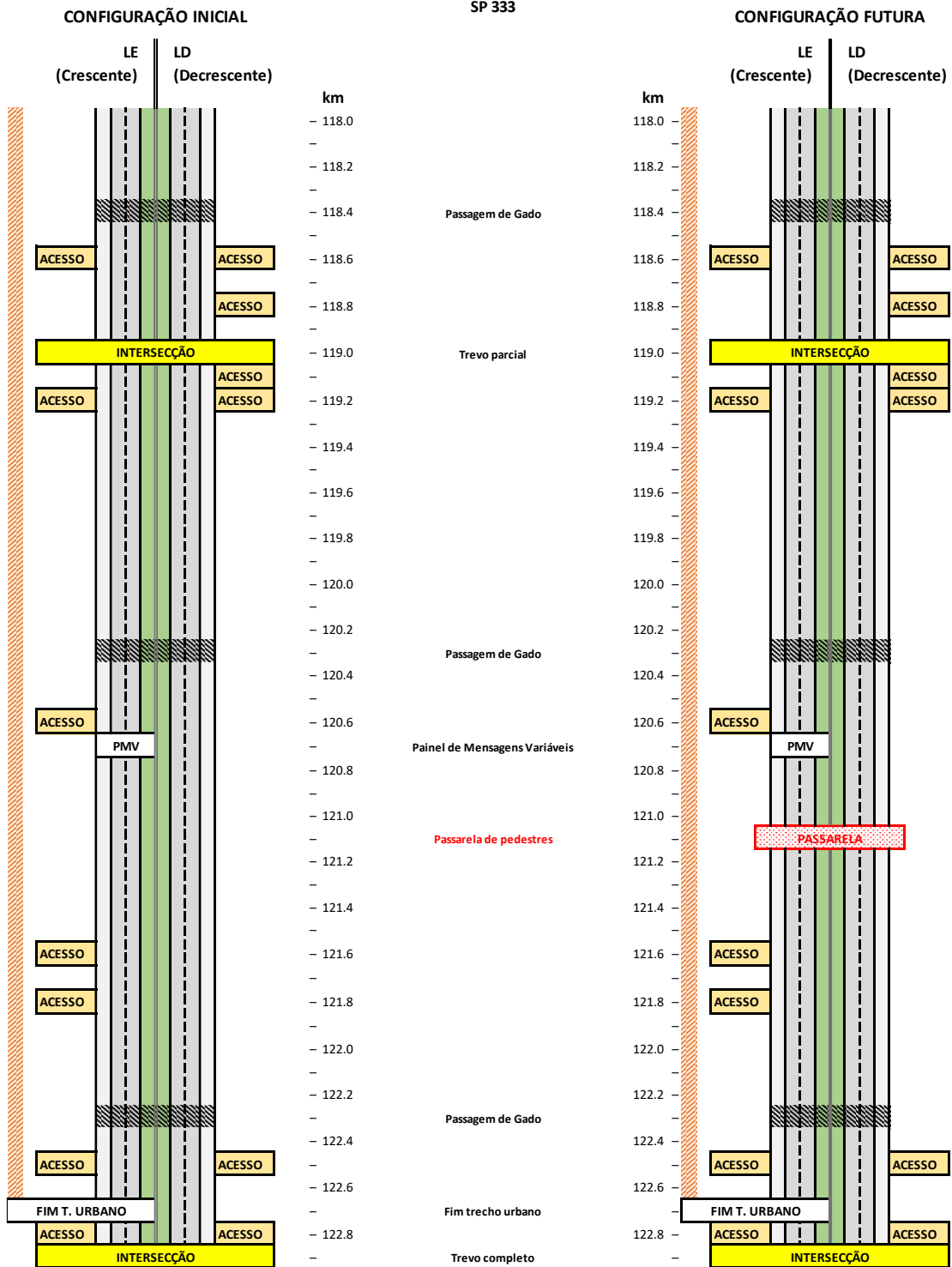

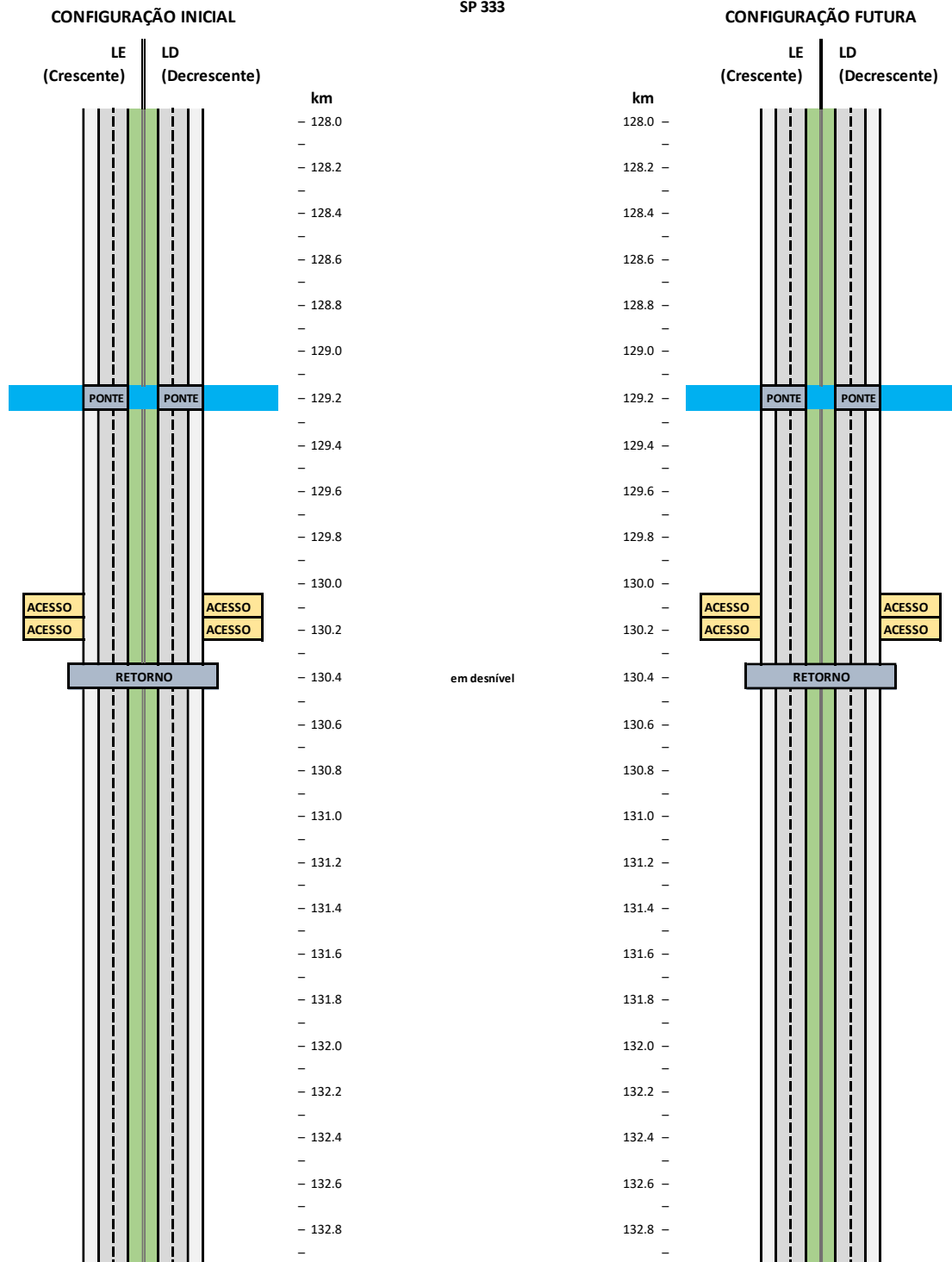

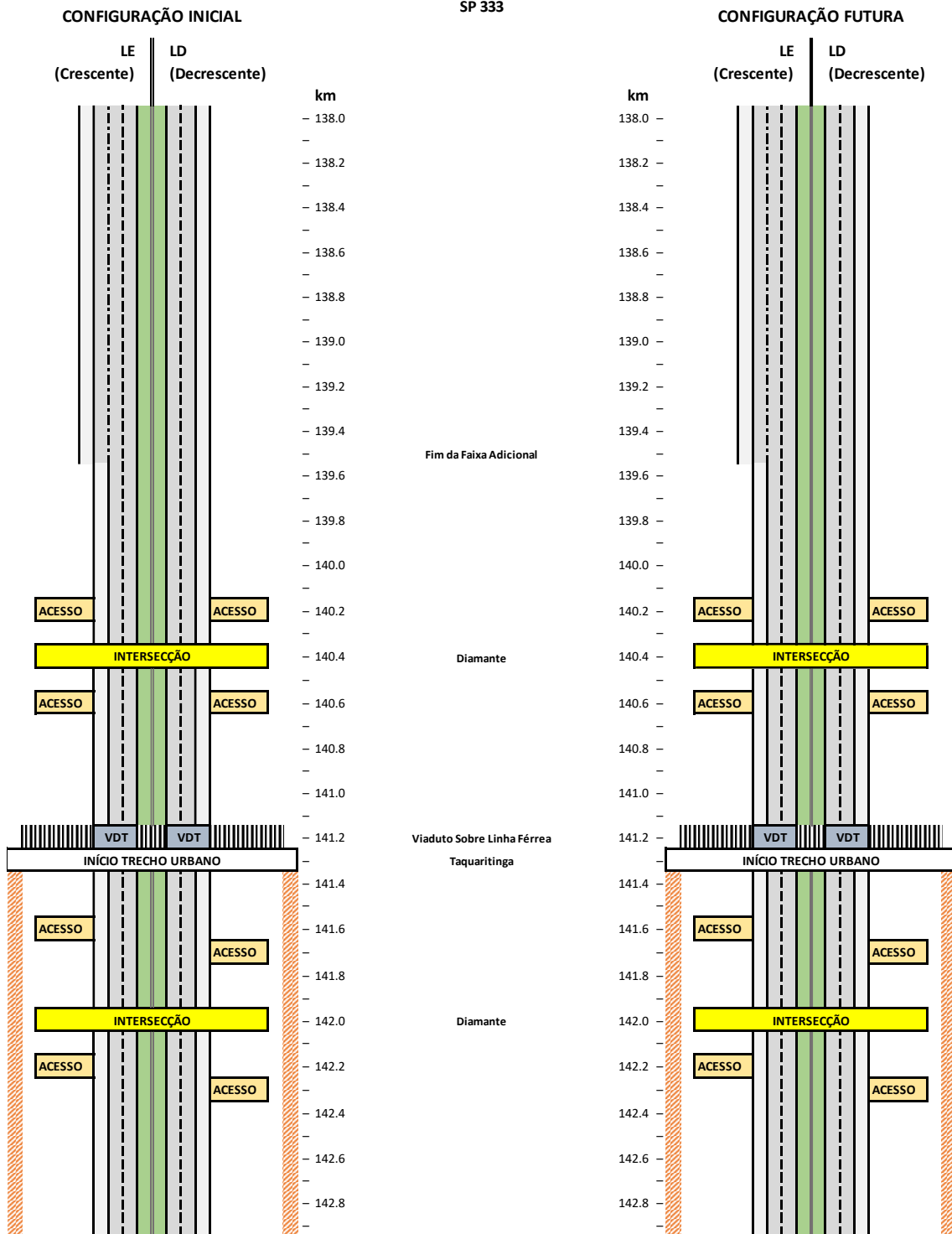

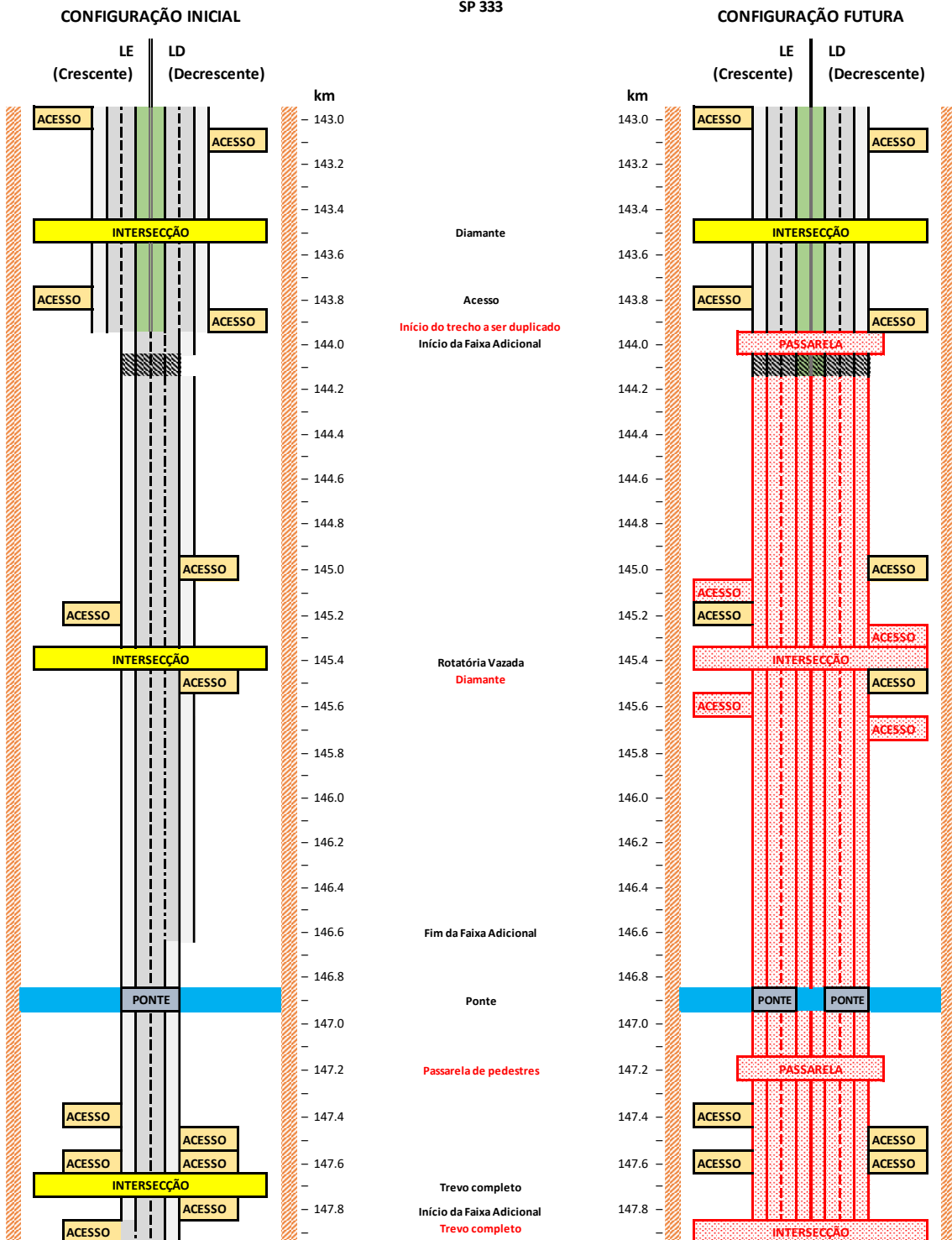

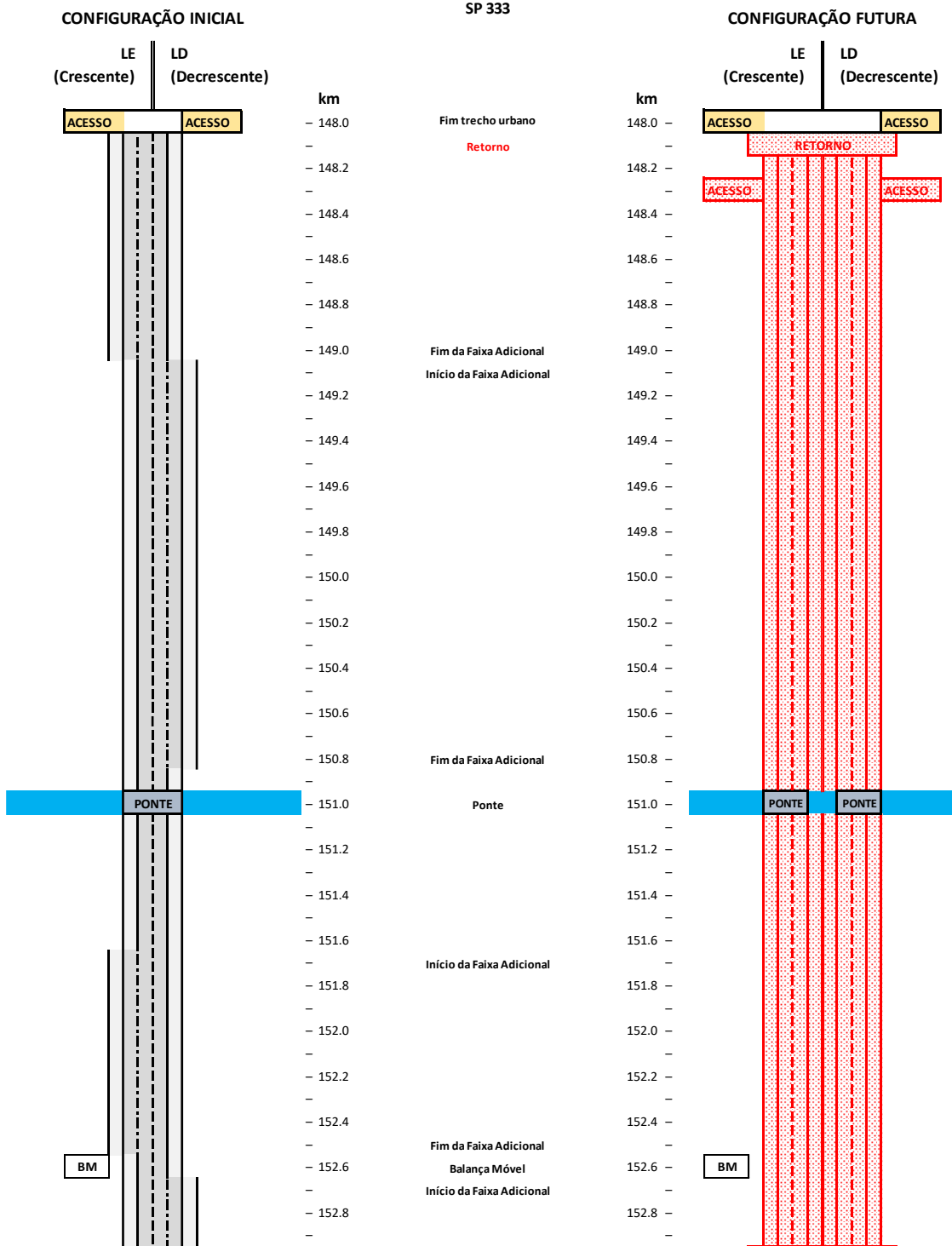

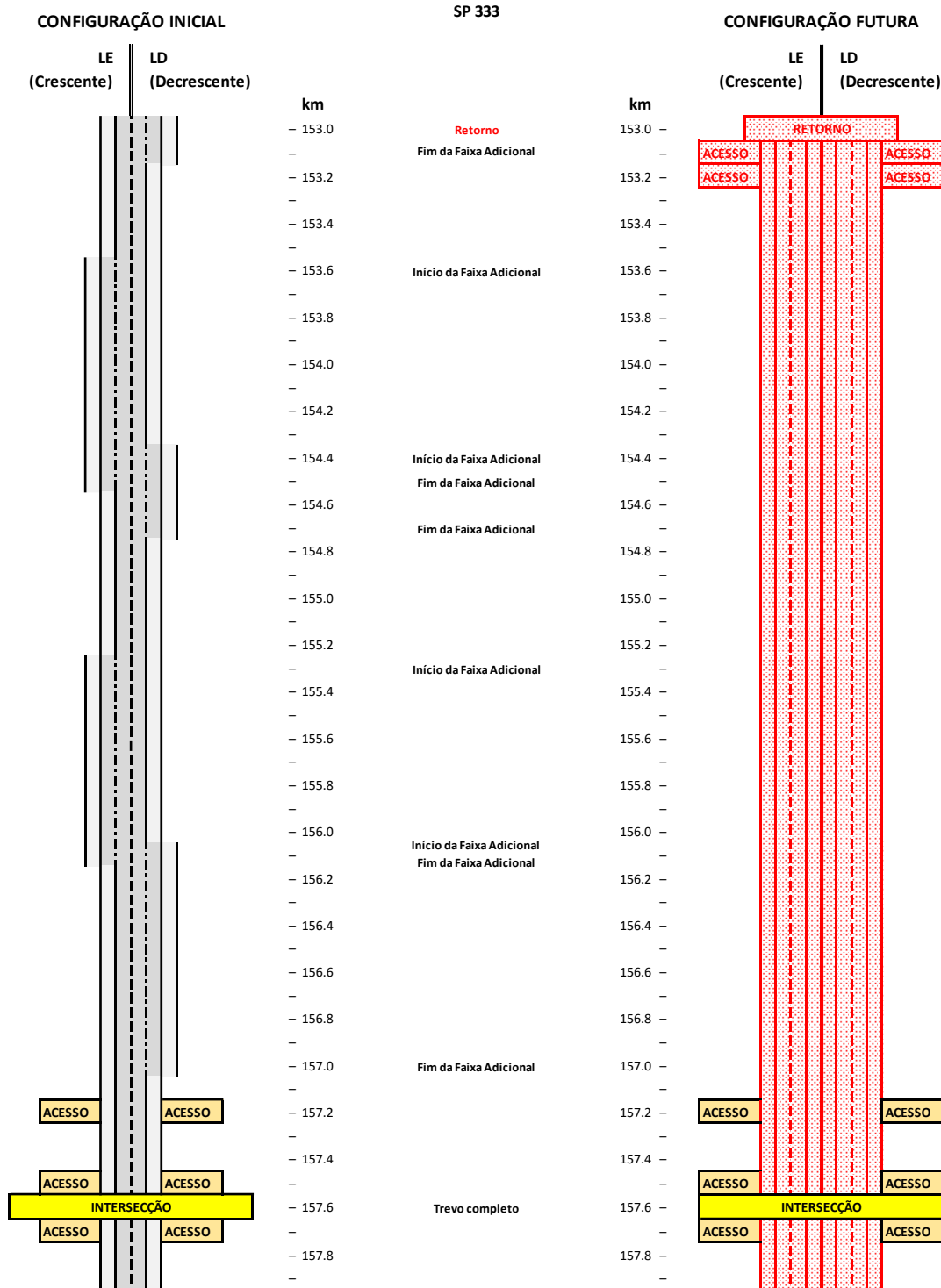

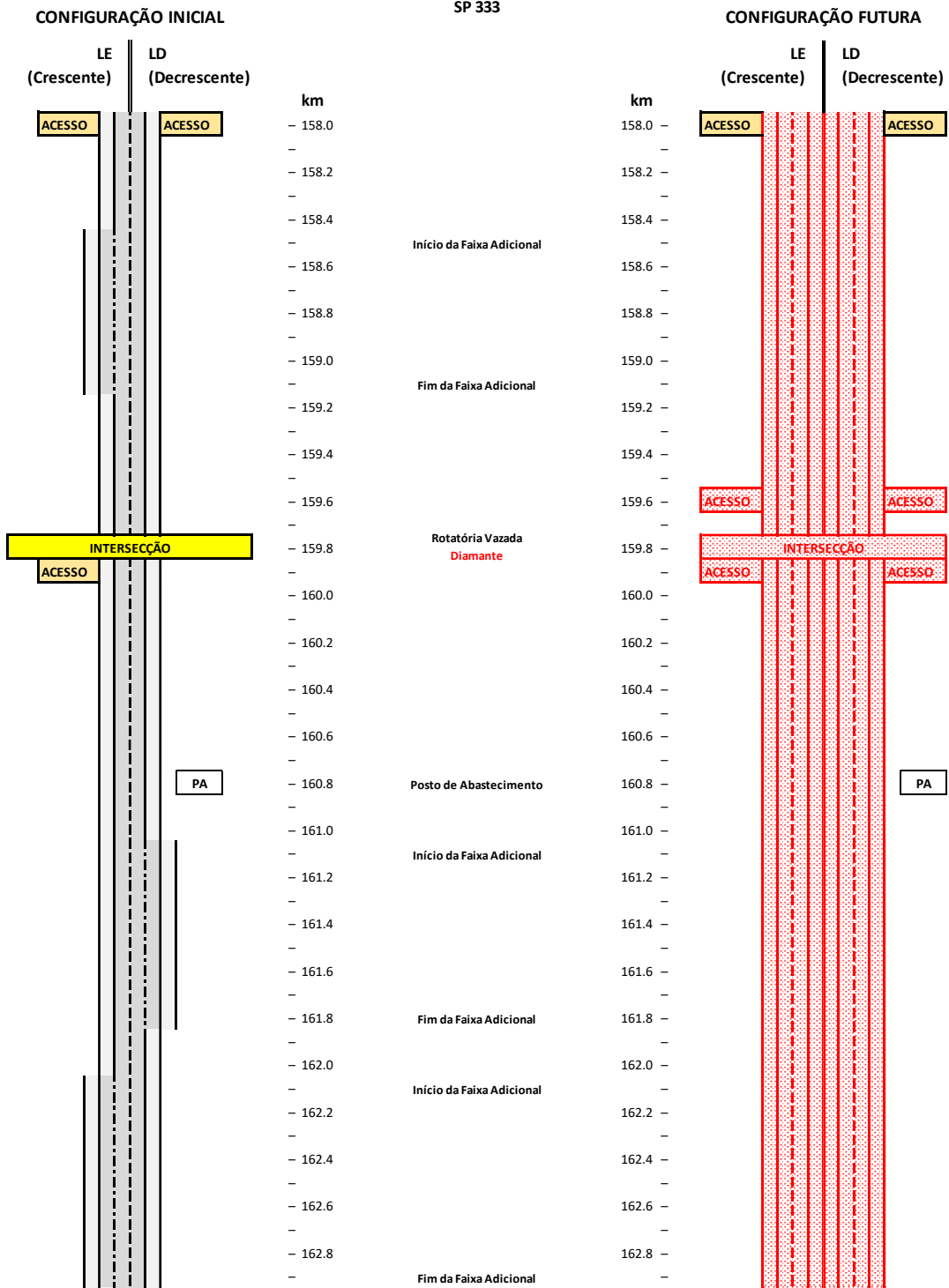

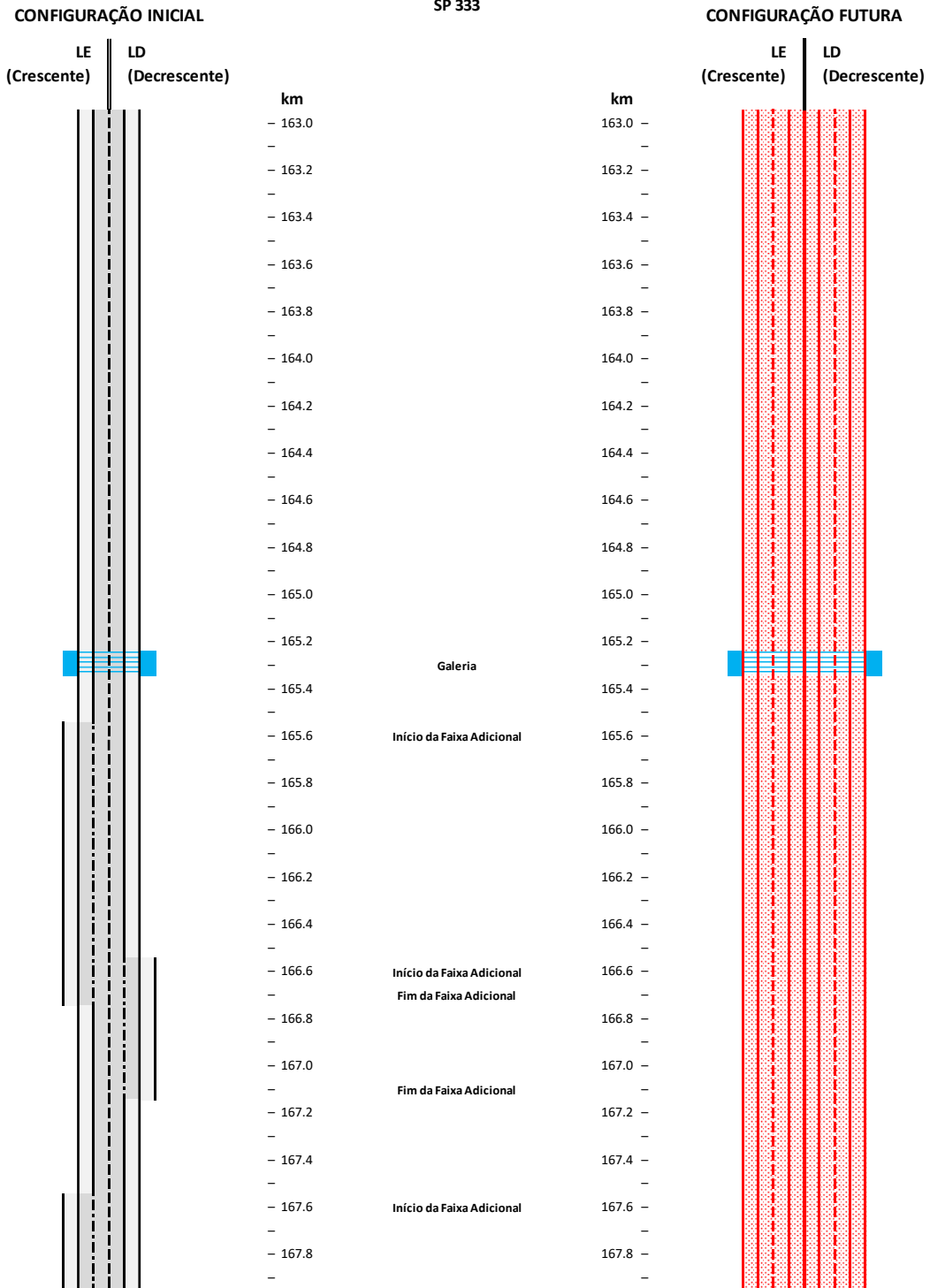

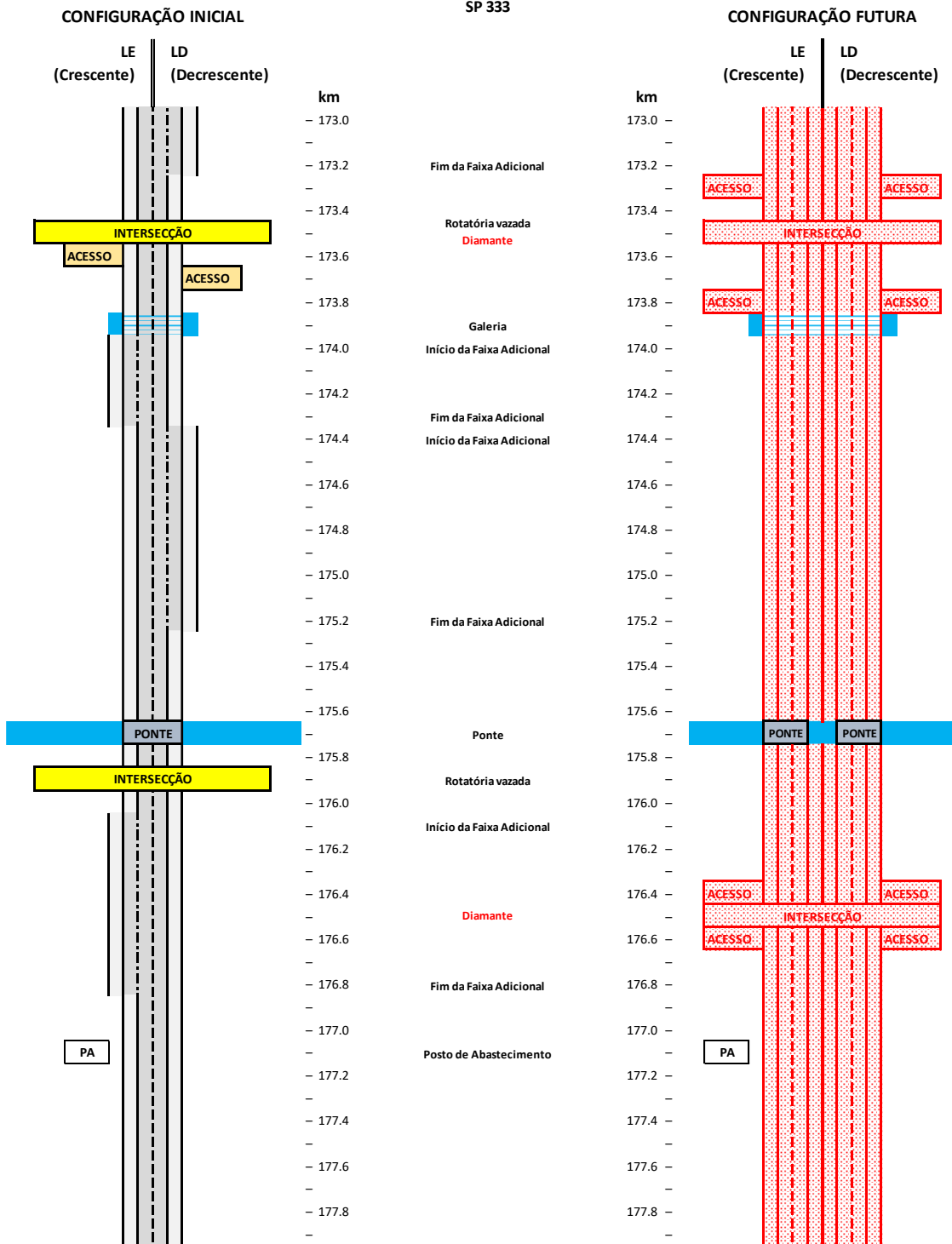

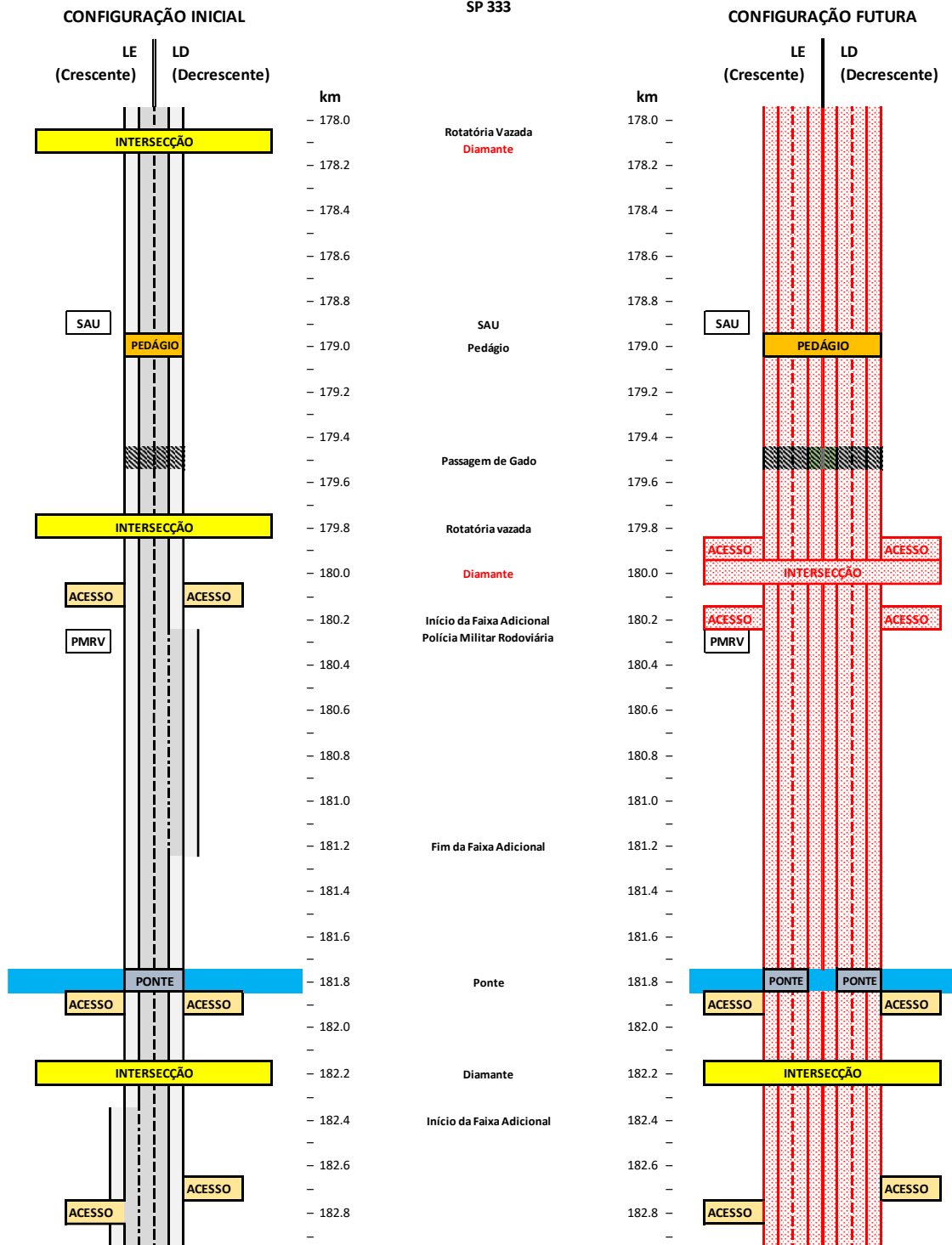

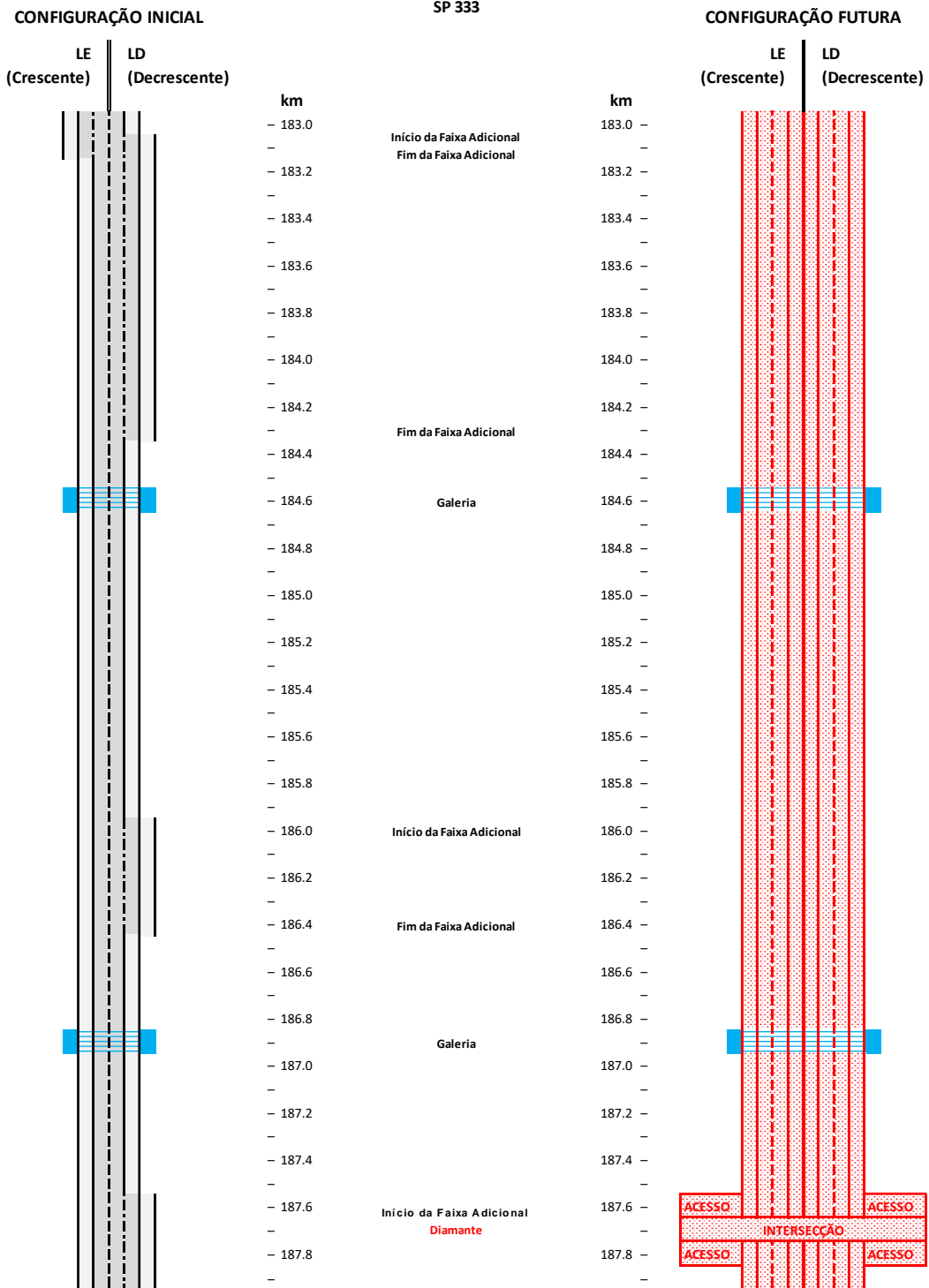

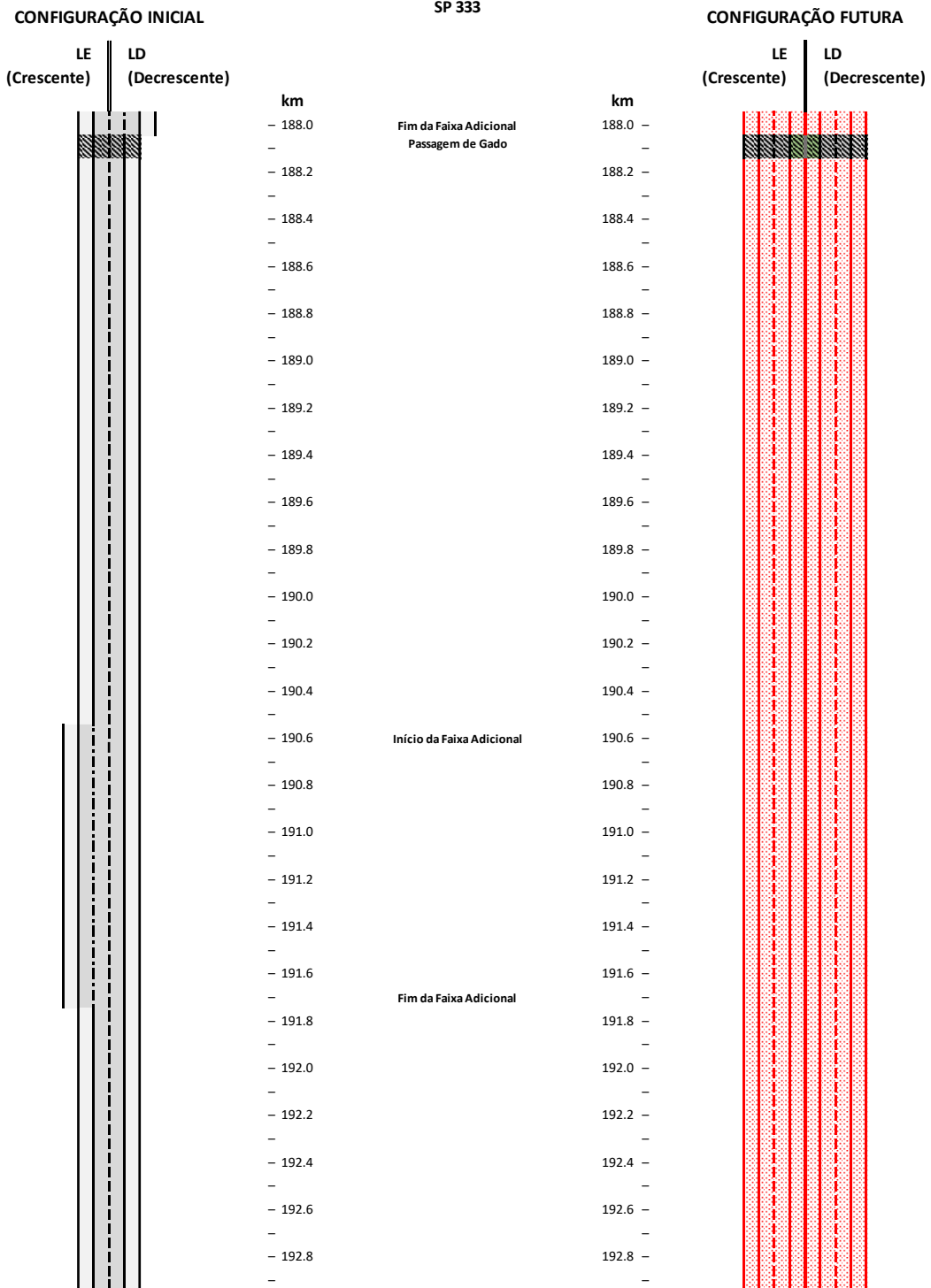

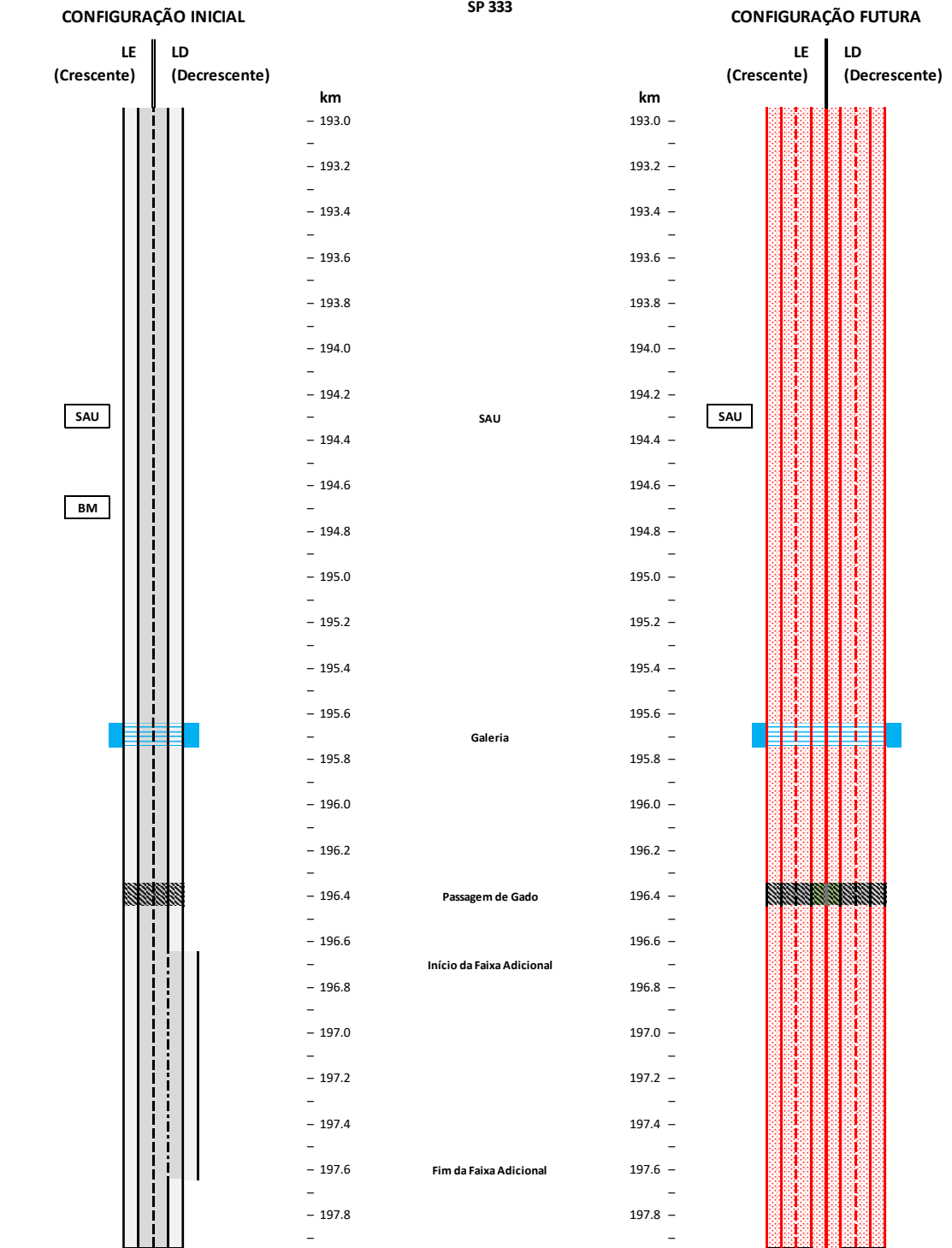

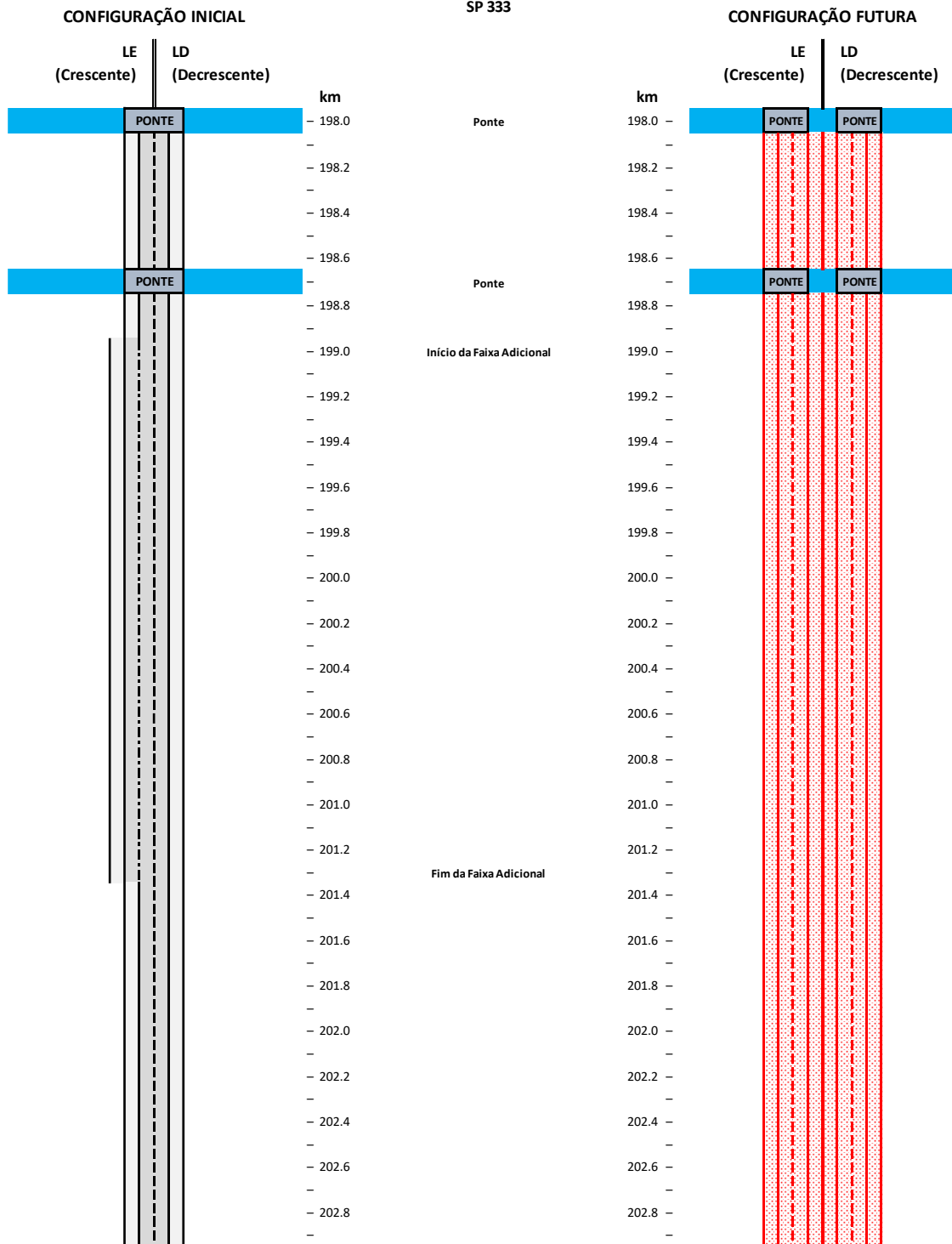

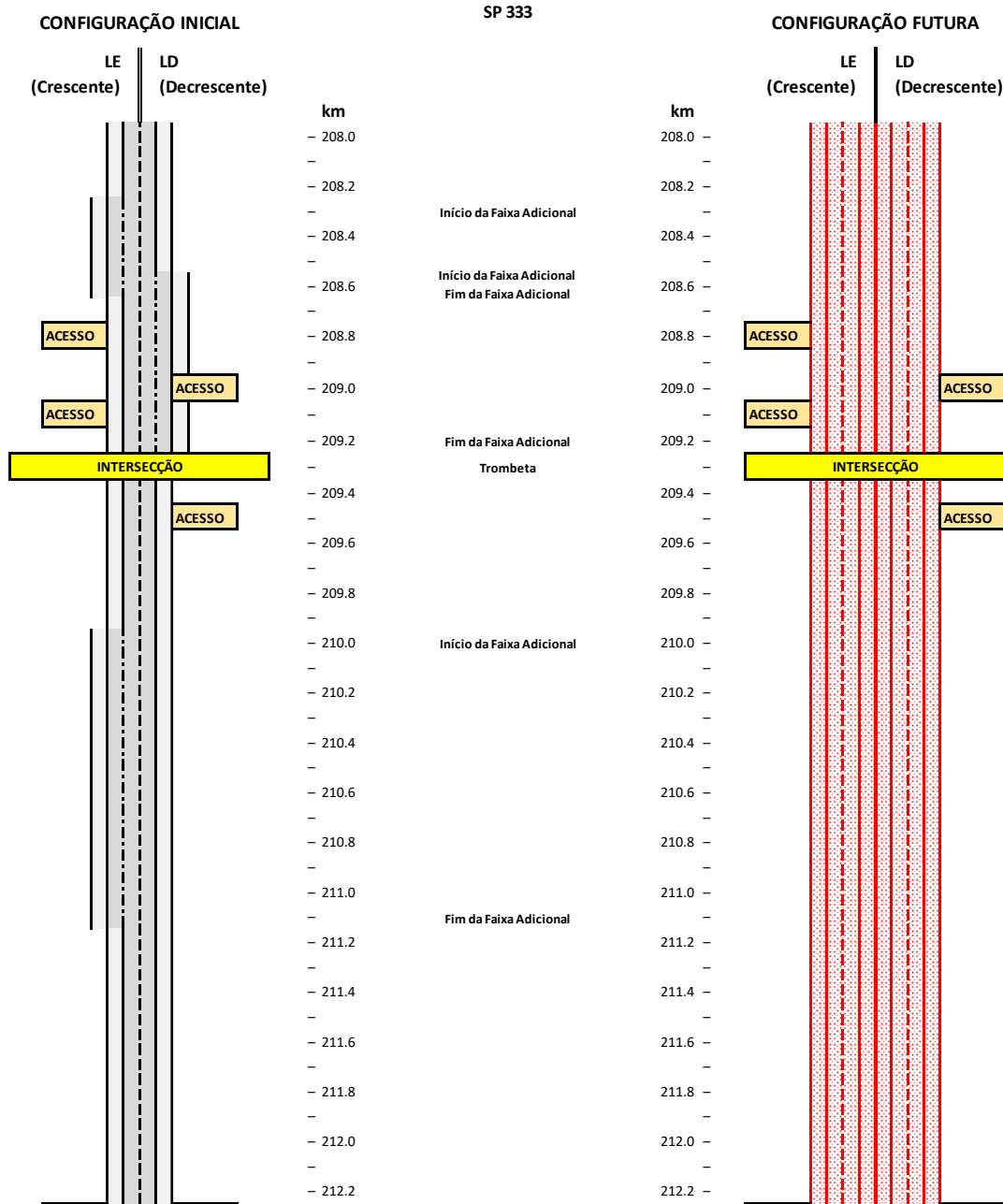

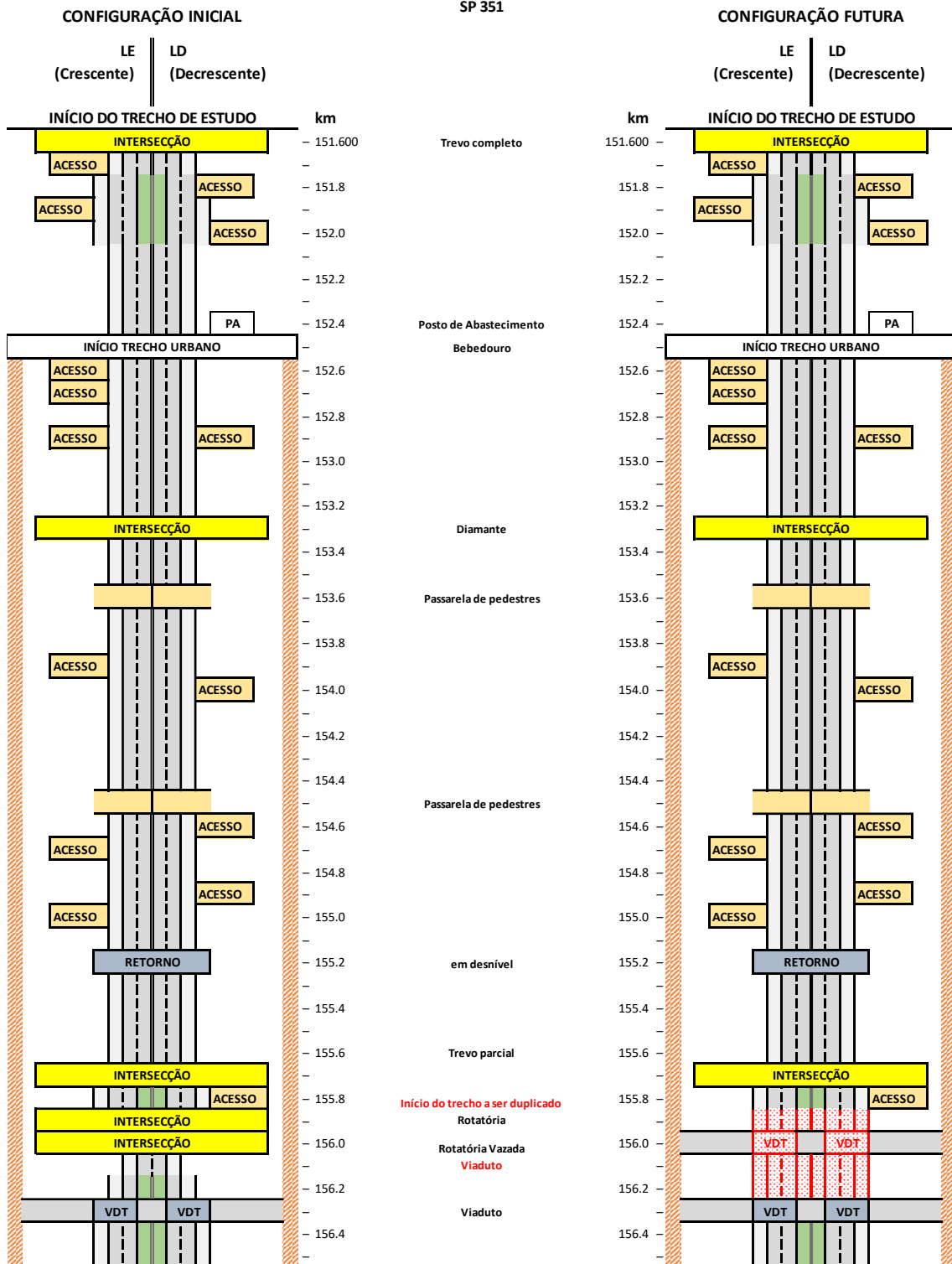

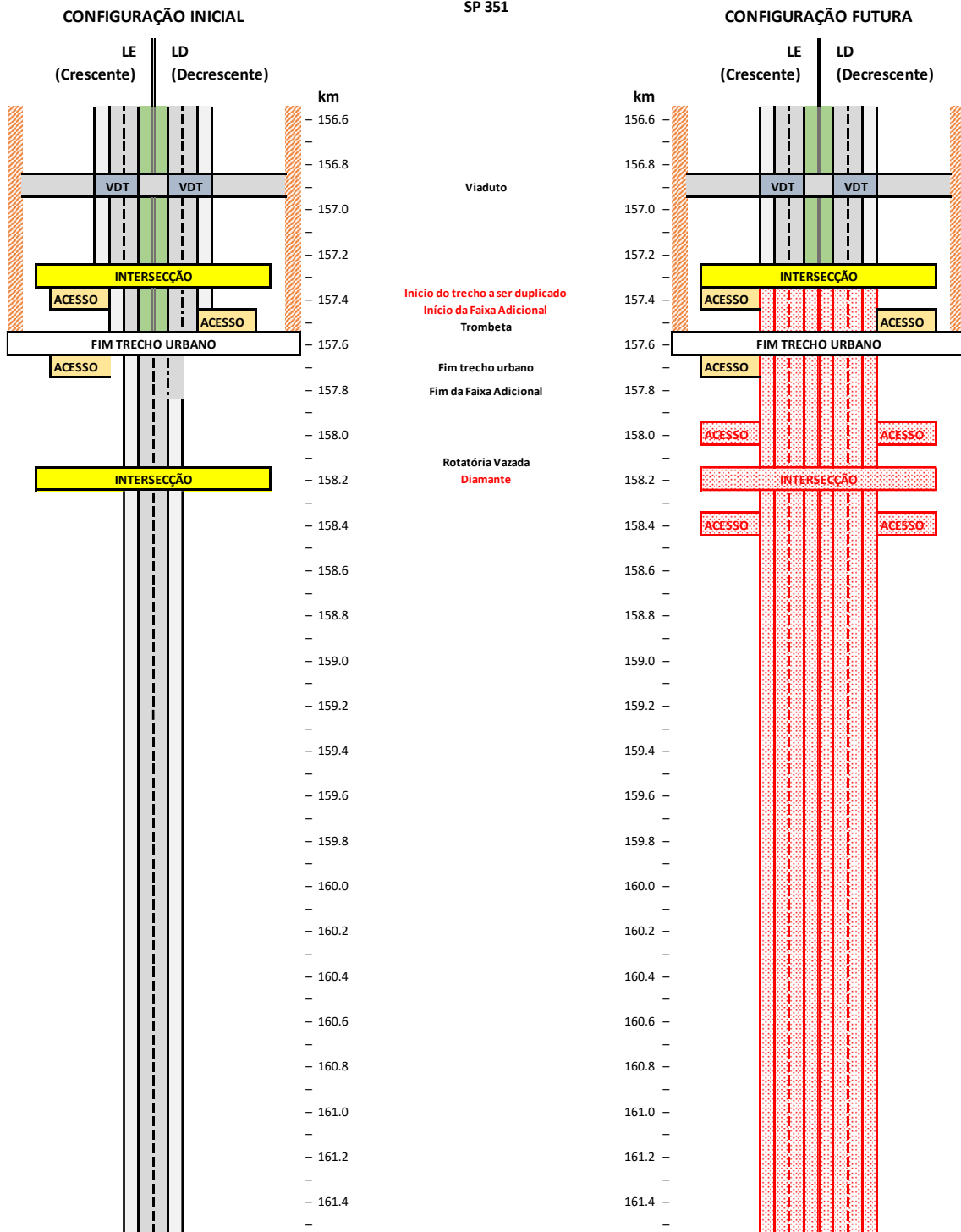

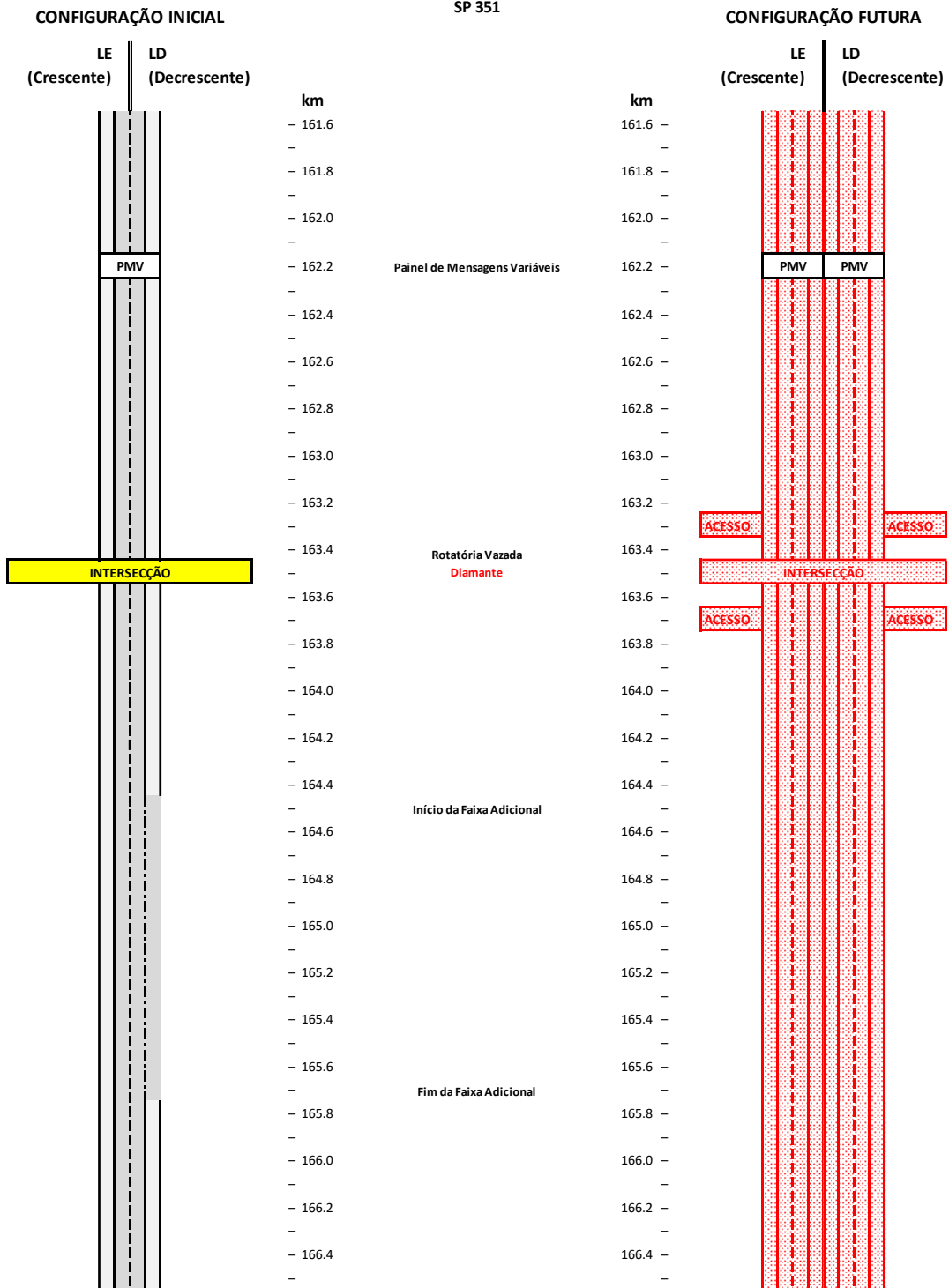

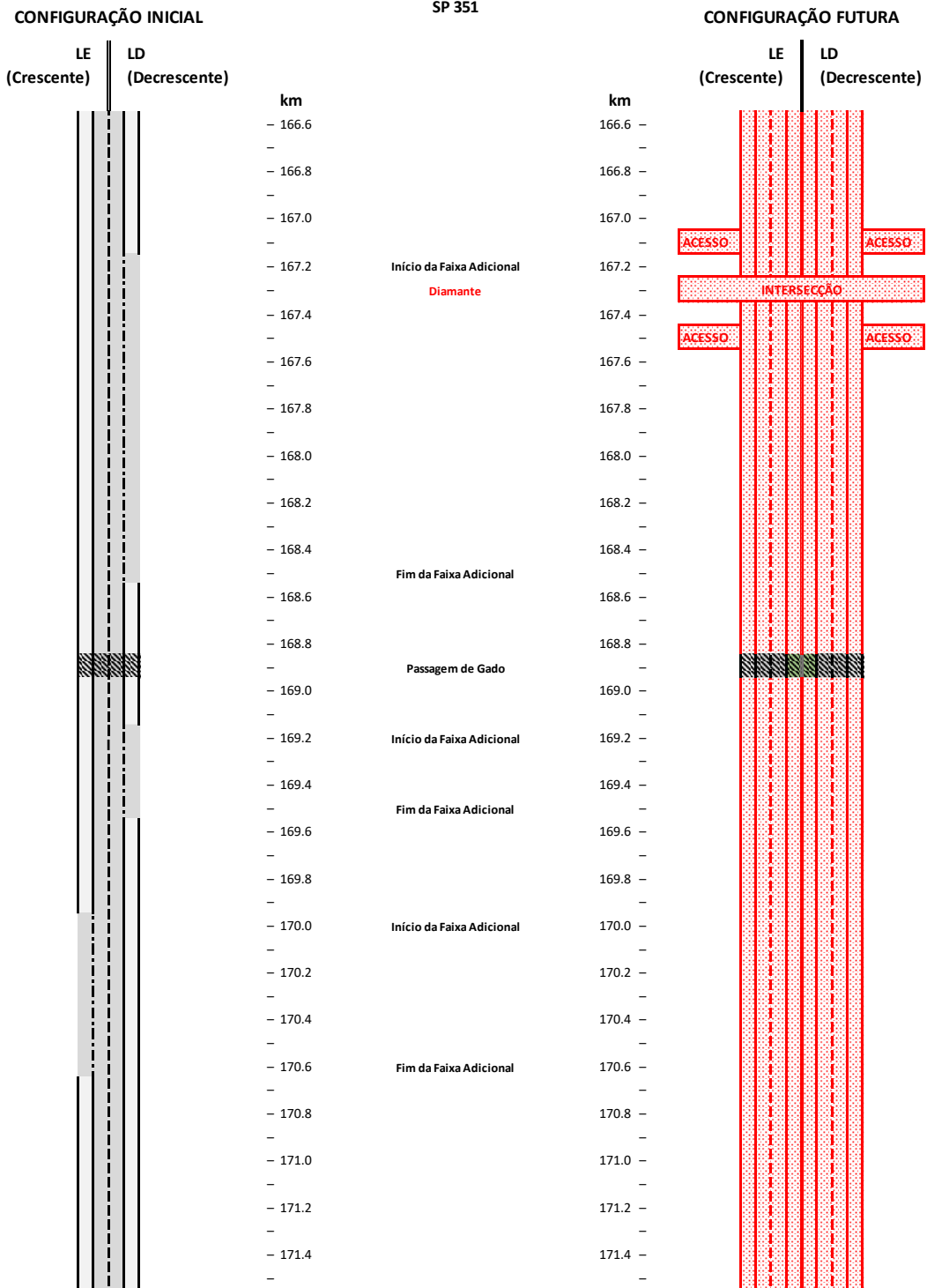

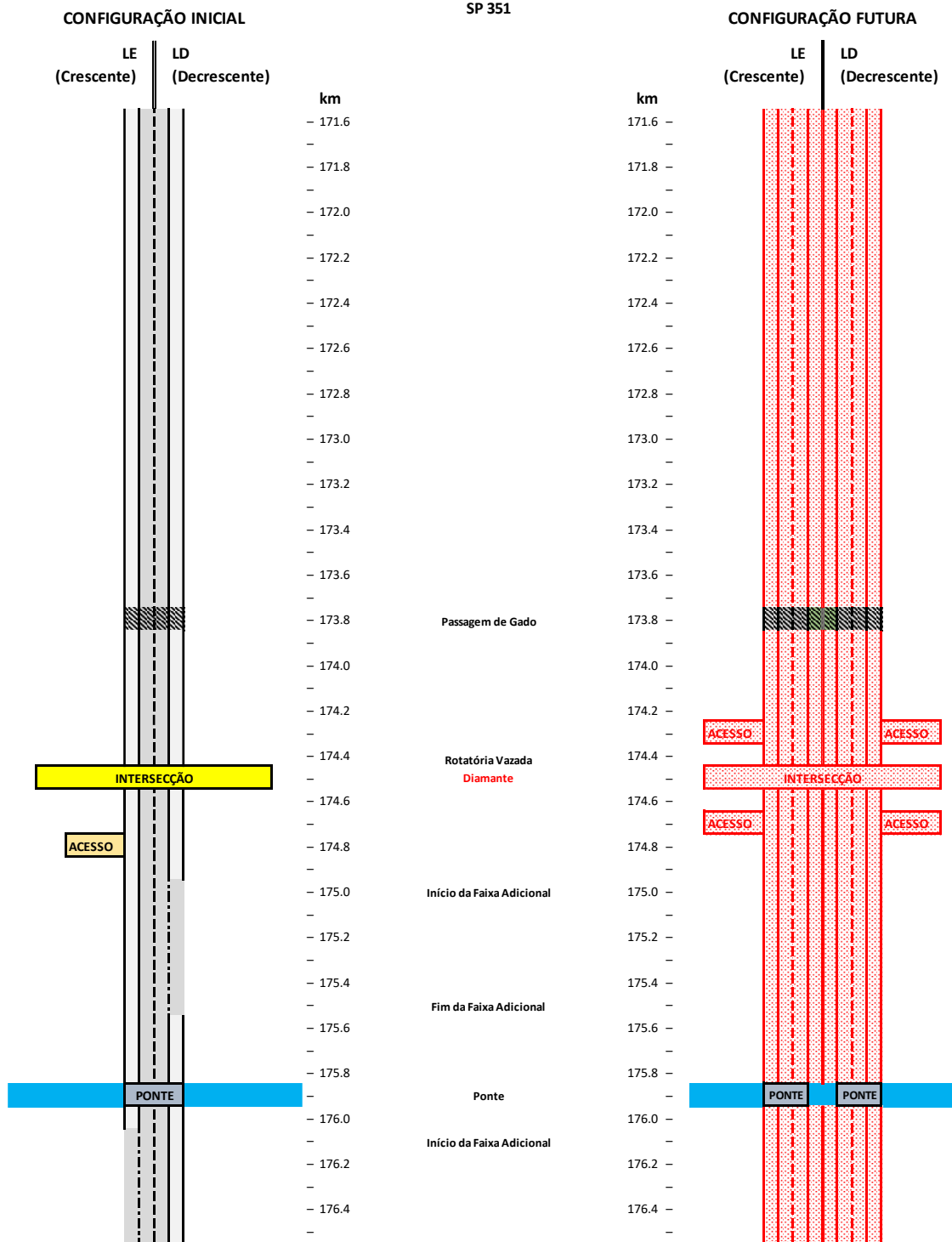

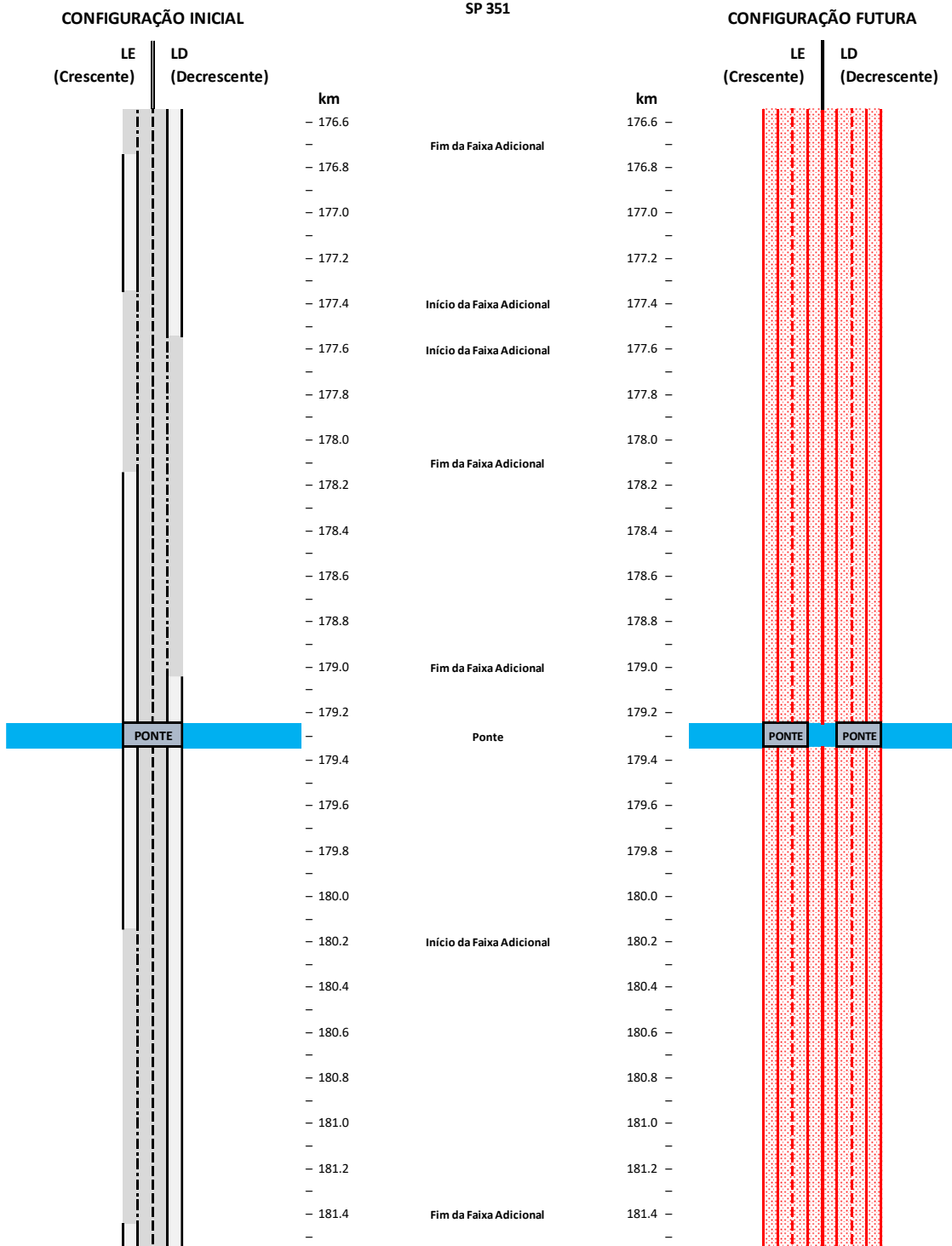

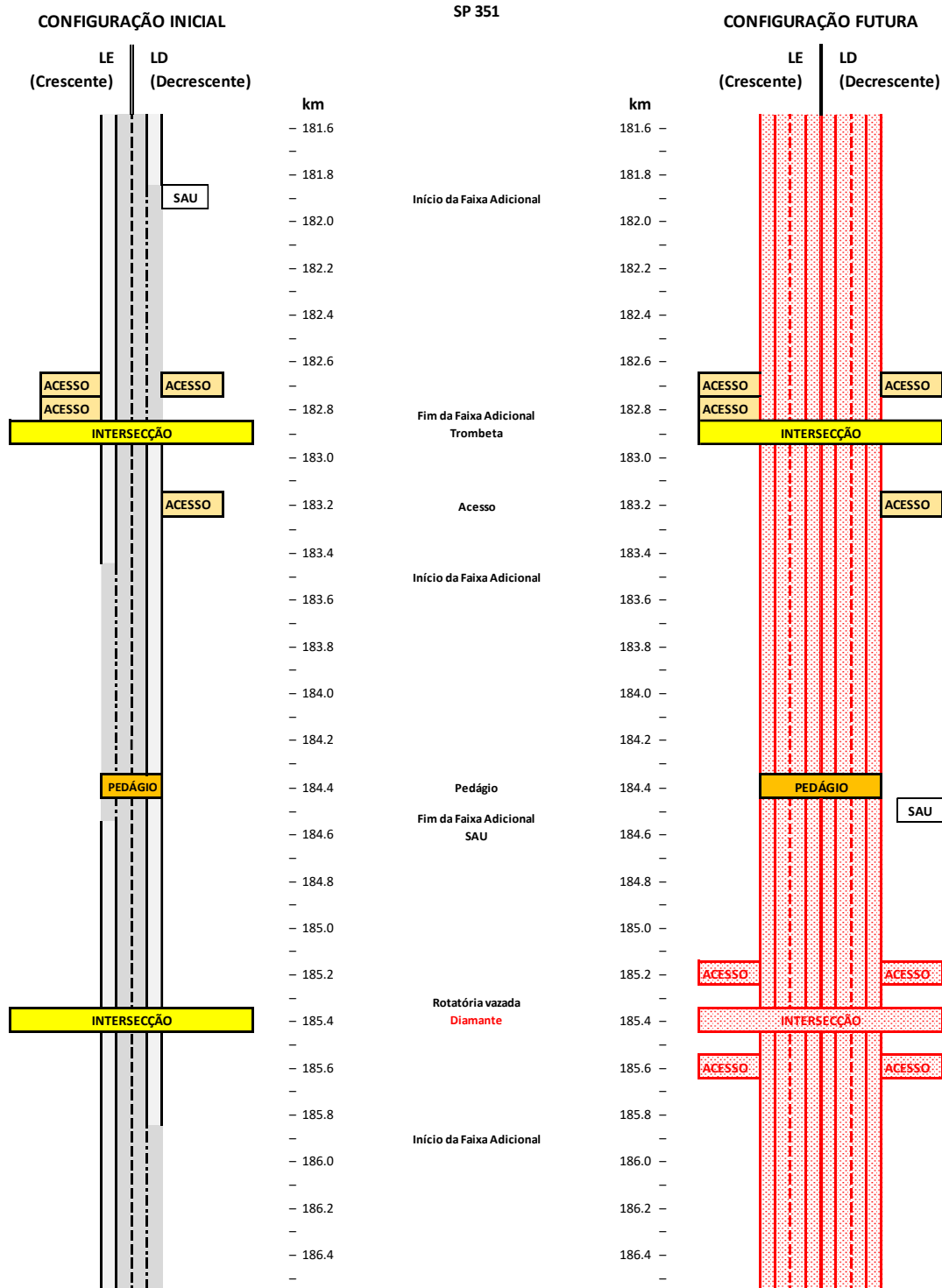

CONFIGURAÇÃO INICIAL		SP 351	CONFIGURAÇÃO FUTURA	
LE (Crescente)	LD (Decrescente)		LE (Crescente)	LD (Decrescente)
		km	km	
		- 186.6	186.6 -	
		-	-	
		- 186.8	186.8 -	
		-	-	
		- 187.0	187.0 -	
		-	-	
		- 187.2	187.2 -	
		-	-	
		- 187.4	187.4 -	
		-	-	
		- 187.6	187.6 -	
		-	-	
		- 187.8	187.8 -	
		-	-	
		- 188.0	188.0 -	
		-	-	
		- 188.2	188.2 -	
		-	-	
		- 188.4	188.4 -	
		-	-	
		- 188.6	188.6 -	
		-	-	
		- 188.8	188.8 -	
		-	-	
		- 189.0	189.0 -	
		-	-	
		- 189.2	189.2 -	
		-	-	
		- 189.4	189.4 -	
		-	-	
		- 189.6	189.6 -	
		-	-	
		- 189.8	189.8 -	
		-	-	
		- 190.0	190.0 -	
		-	-	
		- 190.2	190.2 -	
		-	-	
		- 190.4	190.4 -	
		-	-	
		- 190.6	190.6 -	
		-	-	
		- 190.8	190.8 -	
		-	-	
		- 191.0	191.0 -	
		-	-	
		- 191.2	191.2 -	
		-	-	
		- 191.4	191.4 -	
		-	-	

